

FICTION
MODEL BUILDING
FACT

Three Aviation Magazines in One!

FLYING ACES

JULY
15¢

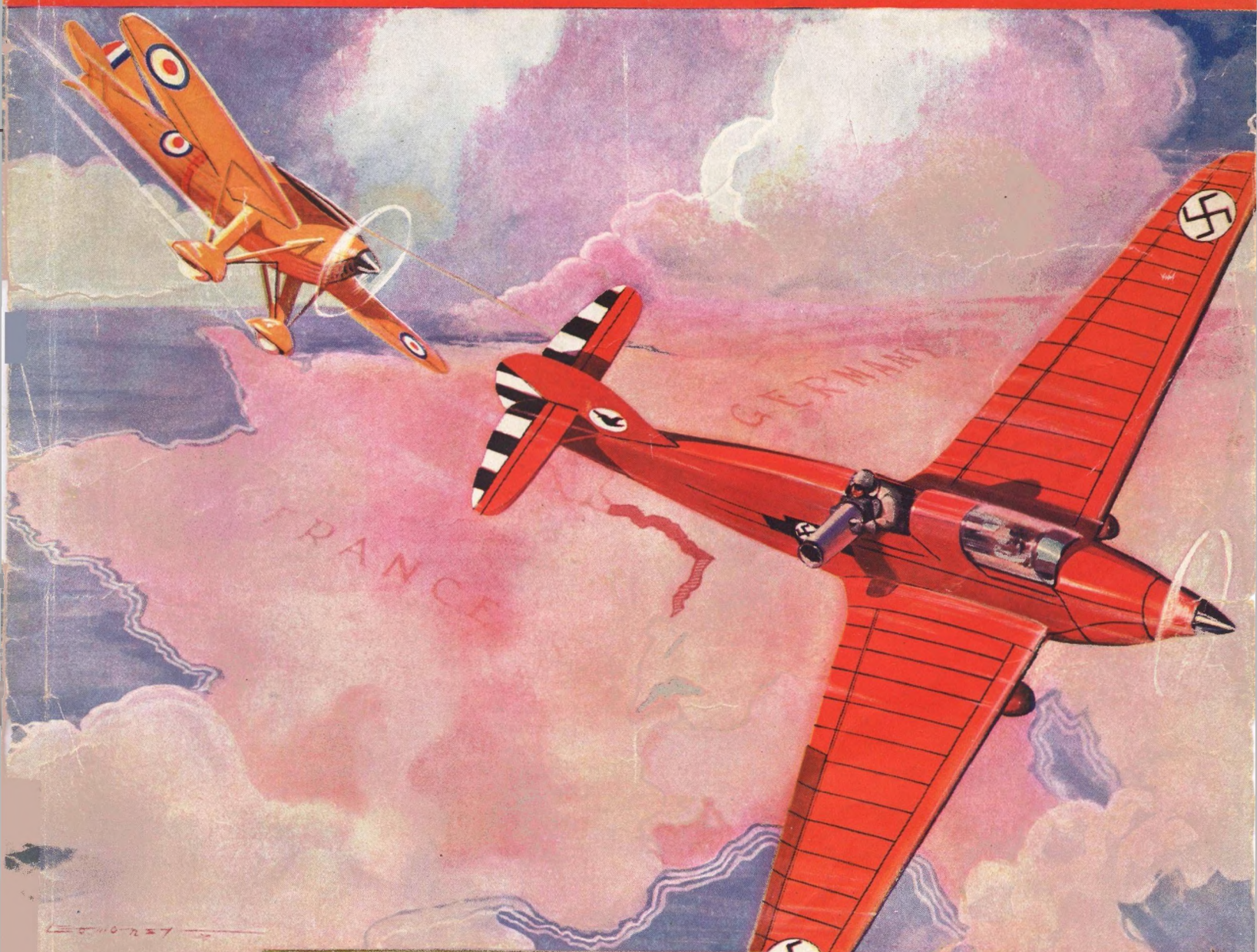

REPULSE OF A RHINELAND CAMERA RAID

GRIPPING STORIES BY KEYHOE, WHITEHOUSE, ARCHIBALD, HUGHES
FEATURE ON SKY FIGHTING TACTICS—DRAMA OF ICELAND AIR MAIL
MODEL PLANS FOR BELLANCA, DOUGLAS BOMBER—GAS JOB ARTICLE

WHAT ELSE CAN I EXPECT, SIS— WITH A FACE LIKE THIS...



BUT JIM FOLLOWS A TIP THAT ENDS HIS JOB WORRIES

OH. HELLO, JIM... HOW ABOUT THE JOB... ANY LUCK THIS TIME?

NOPE—DREW ANOTHER BLANK—GEE, IT'S DISCOURAGIN'—OTHER FELLOWS DON'T HAVE BAD BREAKS LIKE I DO!

I WISH JIM DIDN'T WORRY SO ABOUT A JOB. HE'S AWFULLY UPSET, TOO, ABOUT ALL THOSE PIMPLES HE HAS

I DON'T BLAME HIM. PIMPLES ARE SO CONSPICUOUS— BUT CAROL, I'M SURE FLEISCHMANN'S YEAST WOULD GET RID OF THEM. DO GET HIM TO TRY IT

LISTEN, JIM— KIT SAID THIS FLEISCHMANN'S YEAST IS THE BEST THING OUT FOR PIMPLES. SO I GOT YOU SOME. TRY IT PLEASE!

SAY, IF IT CLEARS 'EM UP, I'M YOUR SLAVE FOR LIFE

LATER

SO LONG— I'VE A HUNCH I'M GOING TO LAND THIS JOB!

BET YOU DO JIMMY— YOU LOOK SO UP- AND-COMING SINCE YOU GOT RID OF THOSE OLD PIMPLES

THE NEXT DAY

3 MONTHS LATER

WHAT D'YOU KNOW— THEY'RE GIVING ME A RAISE AND A BETTER JOB — GOSH, I CAN HARDLY BELIEVE MY LUCK!

OH, JIM— HOW PERFECTLY GRAND!

PRIVATE



—clears the skin
by clearing skin irritants out of the blood

Copyright, 1936, Standard Brands Incorporated

Don't let Adolescent Pimples keep YOU down on your luck

YOUNG PEOPLE are frequently distressed by pimples after the start of adolescence—from about 13 to 25, or even longer.

Important glands develop during these years, and final growth takes place. The entire system is disturbed. The skin gets oversensitive. Waste poisons in the blood irritate this sensitive skin—and pimples appear.

Eat Fleischmann's fresh Yeast to clear these skin irritants out of the blood. Then—pimples vanish!

Eat 3 cakes daily, a cake ½ hour before each meal—plain, or in a little water—until your skin clears. Start today!



STUDENT NOW TEACHES AVIATION

"Your Course certainly has been of great assistance to me in teaching the boys in my class the fundamentals of aeronautics." J. C. HELBIG, JR., Assist. Educational Advisor, Co. 1391, Camp NP-8-VA, Roselyn, Va.



Walter Hinton:

trail blazer, pioneer, explorer, author, instructor, AVIATOR. The first man to pilot a plane across the Atlantic, the famous NC-4, and the first to fly from North to South America. The man who was a crack flying instructor for the Navy during the War; who today is training far-sighted men for Aviation. Hinton is ready to train you at home in your spare time. Send for his Free Book—TODAY.

MANY MAKE \$40, \$60, \$75, A WEEK

Let Me Show You How to Get Into This Fast Growing Industry

My up-to-date home study Course gives you the ground work you need to *get and keep a real job* in this fascinating, fast-growing industry. Many of my graduates, who didn't know a thing about Aviation before they enrolled, are holding down fine jobs right now—in the air and on the ground. Get the facts about my practical training and what it has done for others. Mail coupon now.

I Teach You QUICKLY—at Home in Your Spare Time

You don't need to give up your present job—don't need to leave home, to get your training in Aviation. I've made it easy for you. I've put my own eighteen years of experience—five years of instructing in the Navy—all into my thorough, quickly mastered home study Course.

No Previous Experience Needed

You don't need a high school education—don't have to know anything about planes or engines to learn the ground work of Aviation with my Course. Everything is clearly explained—illustrated by hundreds of pictures, drawings and charts—simple and easy to understand.

You Have Many Types of Jobs to Choose From

You have over 40 different types of jobs to choose from once you have the necessary training. You get all the information you need to pass the Government's written examination for Mechanic's or Pilot's Licenses, in a few short months. If you want to learn to fly, I can probably save you more than the cost of my Course at good airports all over the country.

Aviation is Growing Fast

Don't wait and let the other fellows get ahead of you. Think about your own future. Get the FACTS. Mail the coupon on the right today—right now—while you're thinking about it. I'll send you my big new FREE Book—packed with interesting facts about your opportunities in Aviation. Do it NOW.

WALTER HINTON, Pres.

Aviation Institute of America, Inc.

1115 Connecticut Avenue Washington, D. C.

AIRPLANE FLIGHT INCLUDED

"Give her the gun!" You're off! As soon as you complete my course, I arrange a flight for you at an accredited air field. It doesn't cost you a penny. It is my graduation present to you.



Mail for my big FREE BOOK on AVIATION NOW!

Walter Hinton, President

935-W

Aviation Institute of America, Inc.

1115 Connecticut Avenue, Washington, D. C.

Please send me a Free copy of your book, "Wings of Opportunity." I want to know more about my opportunities in Aviation, and your tested method of home training. This request does not obligate me. (Write clearly.)

Name

Address Age

City State

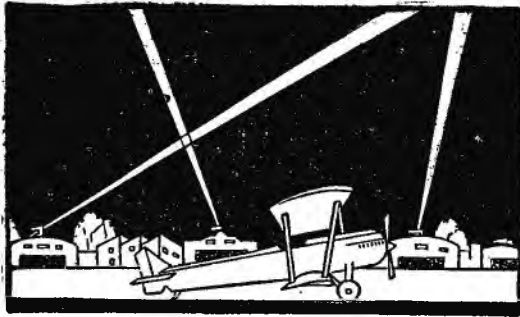

**READERS—FIRE SOME
“TRACERS”!**

AFTER you've revved your way through this issue, mark the stories, articles, model features, and departments that you liked best on the contents list below. Then tear out the page and send it in. These “tracer” shots will guide us to our target—a better-than-ever FLYING ACES!

FLYING ACES

A. A. WYN, Editor

HERB POWELL, Managing Editor

VOLUME XXIII

JULY, 1936

NUMBER 4

EVERY STORY COMPLETE—NO SERIALS

DROME OF THE BAT STAFFEL	DONALD E. KEYHOE	4
Those men who faced Captain Strange feared nothing—nothing except light!		
ICELAND'S SHARK-SHOOTING AIR MAIL . . .	CHARLES S. STRONG	10
Fly with Mr. Strong on the World's strangest mail run!		
SCRATCH-AS-SCRATCH-CAN	JOE ARCHIBALD	14
Phineas & Rollo, Inc., vs. Flanagan, Von Bull, Napoleon, Danton, and Dubarry.		
TACTICS AND STRATEGY OF SKY FIGHTING . . .	DAVID MARTIN	18
The thrilling story of attack and defence, with diagrams of maneuvers.		
SKY GUN SNARE	ARCH WHITEHOUSE	20
Kerry Keen unwittingly baits a trap. And it nearly catches — the Griffon!		
REPULSE OF A RHINELAND CAMERA RAID		23
A Franco-Nazi clash over the Maginot Line — the story behind our cover.		
CUNNING OF THE CAMERA HAWK	JAMES PERLEY HUGHES	24
Mason's only way out of that jam was to shoot. Yet shooting meant — another jam!		

MODEL MAKERS' SECTION

WITH THE MODEL BUILDERS		31
BUILD THE SENIOR PACEMAKER	DAVIDSON & APPEL	32
MAKE THE DOUGLAS BOMBER	ROBERT C. MORRISON	38
TRY A SOLID MODEL BRISTOL FIGHTER	NICK LIMBER	40
THE FLYING ACES PARASOL	LOUIS GARAMI	41
FLYING ACES MODEL LABORATORY	AVRUM ZIER	44
FROM THE MODEL BUILDER'S WORKBENCH		46
SOMETHING NEW! A CARDBOARD CUT-OUT MODEL . .	HERB LOZIER	47
WAR MODEL FANS—BUILD THE A.E.G. BOMBER . .	H. BUTTERFIELD	50

DEPARTMENTS AND FEATURES

SNAPSHOTS OF THE WAR	9	MODERN PLANES ALBUM	52
SIMPLIFIED AVIGATION	13	FLYING ACES CLUB NEWS	54
WISECRACK-UPS	17	F.A.C. TRANSPORT CONTEST	55
ALL QUESTIONS ANSWERED	27	CITATIONS AND AWARDS	56
NOW WE'LL ASK YOU A FEW	27	THE NEW AIRMAIL PALS	56
HAPPY LANDINGS	28	JOIN THE FLYING ACES CLUB	57
ON THE LIGHT PLANE TARMAC	29	IN THE NEXT ISSUE	58
PILOTOPICS	30	ADVERTISER'S CONTACT	77

Cover Painting by Leo Morey

Published monthly by Magazine Publishers, Inc.; office of publication, 29 Worthington St., Springfield, Mass. A. A. Wyn, President; Warren A. Angel, Secretary-Treasurer. Editorial and executive offices, 67 W. 44th St., New York. Entered as second-class matter, Nov. 14, 1928, at Springfield, Mass., under Act of March 3, 1879. Title registered in U. S. Patent Office. Copyright, 1935, by Magazine Publishers, Inc. Nothing may be reprinted without permission of the publishers. Manuscripts will be handled with care, but this magazine assumes no responsibility for their safety. For advertising rates address FLYING ACES Magazine, 67 W. 44th St., New York City.

Twelve Issues, \$1.50

Single Copies, Fifteen Cents

SELLEY-TEX ARE THE ONLY KITS WITH MOULDED PARTS!

Reg. U. S. Pat. App. For

This revolutionary, simplified method takes the "GUESS" out of model building
The Most Practical Construction Idea in Flying Model History!



Moulded Parts for
LOCKHEED ORION
1. Right fuselage shell,
2. Left fuselage shell,
3. Cowling,
4. Motor plate,
5. Cylinder strip,
6. Cabin

Each of the SELLEY-TEX Construction Sets contain the necessary individually designed moulded scale parts similar to those shown above.

Wing Span, 20"
Length, 12 1/2"

LOCKHEED ORION

An amazing realistic replica of this famous transport

This latest formidable looking military plane is complete with guns, bombs, etc. Is built for stamina and designed for speed.



125
15c Postage

VOUGHT CORSAIR, JR.

Wing Span, 19"
Length, 12 1/2"

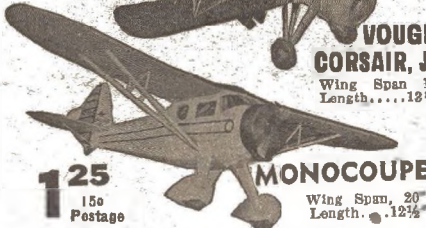

125
15c Postage

MONOCOUCPE

Wing Span, 20"
Length, 12 1/2"

A beautiful miniature of the popular original and what a flyer!

"There has never been a finer or more practical line of kits created than SELLEY-TEX Construction Sets, The Modern Method of Model Building!" That is the consensus of opinion among aviation authorities, experts and novices as voiced in the many letters of praise and commendation constantly received. Selley's exclusive "moulded" method of construction embraces all the fine features of model airplane building while eliminating the heretofore impossible job of assembling All-Balsa-Stick-Kit fuselages, motors, cowls, parts etc. That's why thousands of disappointed model builders have switched to SELLEY-TEX and found new enjoyment, new thrills in the successful completion of beautifully designed, fast-flying miniatures of popular planes. Hitch YOUR wagon to a "star" SELLEY-TEX Construction Set and FLY! Choose the model you like, see the coupon below and ACT NOW!

SELLEY-TEX OFFERS 10 ADVANTAGES OVER ALL BALSA STICK KITS

- ★ **MOULDED CONSTRUCTION.** First real advancement in practical model airplane building. The production investment exceeds the cost of most of the All-Balsa-Stick-Kit manufacturers combined!
- ★ **EXCLUSIVE FABRIC.** Specially close woven and processed by secret formula. The smooth moulded surface can be beautifully finished in any color combinations with dope or lacquer.
- ★ **EASIER-TO-BUILD.** The moulded parts make it simple as A B C. Novices as well as experts easily and successfully build and fly planes this new simple way.
- ★ **MORE PRACTICAL.** Selley is discontinuing All-Balsa-Stick type of kit entirely. An analysis showed that less than 2% of those who try, can actually complete an All-Balsa-Stick-Kit!
- ★ **MORE AUTHENTICALLY DESIGNED.** Minute details are moulded into model. Each is an exact, true-to-scale miniature of the original plane perfect in every detail.
- ★ **MORE DURABLE.** The moulded fabric shells are stronger though lighter. They will not warp, tear or puncture and are practically crash-proof and unbreakable.
- ★ **BETTER FLYERS.** The moulded fuselage eliminates weight behind center of gravity which is approximately 85% perfect in all models assuring better flying performance.
- ★ **POSITIVE MEANS OF BALANCING.** Simple ring device correctly balances plane. A new clever feature found only in these moulded models.
- ★ **PATENT APPLIED FOR.** The moulded process is an original creation owned exclusively by Selley.
- ★ **MONEY-BACK GUARANTEE.** A full protection money back guarantee certificate is included in every kit!

PARTS AND ACCESSORIES

Every SELLEY-TEX model is packed in a beautiful, sturdy box with semi-finished flying or scale propeller, formed wire hooks, scaled wheels, with brass bushings, ribbed printed or white sheet balsa, many special turned wood parts, finest grade of balsa wood sticks, tail wheel and fork fittings, and wire, pure rubber, colored paper, authentic markings, colored insignia, best quality cement, colored dopes and full-size easy-to-understand plan.



Simple as ABO

- A**—Fit together and cement the two moulded parts of the fuselage.
- B**—But away the excess fabric.
- C**—The result is a perfectly shaped fuselage in the form of a hollow shell, very strong and indestructible.



All other SELLEY-TEX moulded parts as listed are equally easy to build.

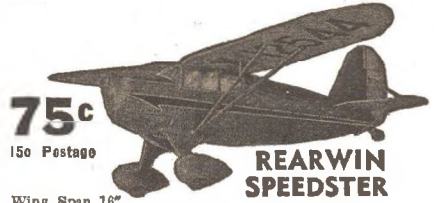

75c
15c Postage

REARWIN SPEEDSTER

Wing Span 16"
Length, 10"

Simple to build and realistic in all details! A great flyer too! Wonderful Value!

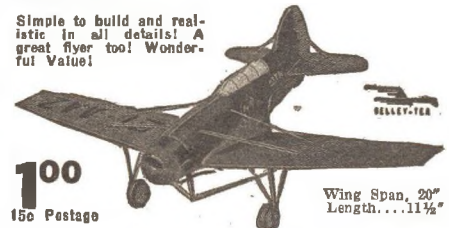

100
15c Postage

BELLANCA SWOOP

Wing Span, 20"
Length, 11 1/2"

A perfect authentic reproduction of this famous London to Melbourne racer.

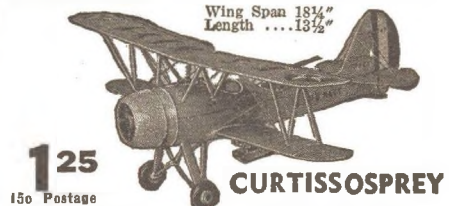

125
15c Postage

CURTISSOSPREY

Wing Span 18 1/4"
Length, 13 1/2"

Exceptional flight performance, authentic beyond belief. Full military equipment, guns, bombs, etc., for realism.

BUY the FINEST QUALITY PARTS and SUPPLIES

FREE: SPECIAL GAS MOTOR PARTS CIRCULAR. Send 3c to cover Postage.

PICTURES ON BRISTOL BOARD
Authentic Airplanes
24 ARMY 25c Set
18 NAVY 25c Set
16 WARTIME 25c Set
84 SQUADRON INSIGNIA 25c

Spun Aluminum COWLS

	Drag	Open	Ring	Face	Closed
1 1/2"	15	15	15	15	15
1 3/4"	18	18	18	18	18
2"	20	20	20	20	20
2 1/4"	28	28	28	28	28

Aluminum Disc Rubber Tired Wheels	
1/2" dia.	5c ea.
3/4" dia.	6c ea.
1" dia.	7c ea.
1 1/4" dia.	8c ea.
1 1/2" dia.	9c ea.
1 3/4" dia.	10c ea.
2" dia.	11c ea.

WHEELS

Aluminum Disc Rubber Tired Air Wheels	
1" dia.	15c pr.
1 1/4" dia.	18c pr.
1 1/2" dia.	20c pr.

Celluloid Balsa Wheels	
1 1/2" dia.	10c pr.
1 3/4" dia.	12c pr.
2" dia.	15c pr.

Hawk Type Propeller		DIE CAST		Standard Propeller	
2-bladed	3-bladed	2-bladed	3-bladed	2-bladed	3-bladed
3 1/4" 25c	4" 35c	1 1/2" 8c	1 3/4" 10c	1 1/2" 8c	1 3/4" 10c
4" 30c	4 1/2" 45c	2" 10c	2 1/4" 12c	2" 10c	2 1/4" 12c
4 1/4" 35c	5" 50c	3" 15c	3 1/4" 25c	3" 15c	3 1/4" 25c
5" 35c	5 1/2" 60c	4" 20c	4 1/2" 35c	4" 20c	4 1/2" 35c
5 1/4" 40c	6" 70c	4 1/4" 25c	5" 45c	4 1/4" 25c	5" 45c
6" 45c	7" 80c	5" 30c	6" 60c	5" 30c	6" 60c
6 1/2" 55c	8" 100c	5 1/2" 35c	7" 70c	5 1/2" 35c	7" 70c
7" 55c	9" 110c	6" 40c	8" 80c	6" 40c	8" 80c
8" 65c	10" 120c	6 1/2" 45c	9" 90c	6 1/2" 45c	9" 90c
9" 75c	11" 130c	7" 50c	10" 100c	7" 50c	10" 100c
10" 85c		8" 55c		8" 55c	

Ballon Tire	
1 1/2" dia.	25c pr.
1 3/4" dia.	28c pr.
2" dia.	30c pr.

Alum. Disc Wheels	
1 1/2" dia.	25c pr.
1 3/4" dia.	28c pr.
2" dia.	30c pr.

Treaded Rubber Tire	
1 3/16" dia.	30c pr.
1 1/4" dia.	40c pr.
2" dia.	50c pr.
3" dia.	60c pr.
5" dia.	\$1.50 pr.
6 1/2" dia.	\$2.00 pr.
7" dia.	\$2.50 pr.

RING MOUNT GUNS		SWIVEL TYPE GUNS	
1 1/4" Long B	25c	2" Double Action	15c
1 3/4" Long A	30c	7/8" Ratchet Gun	35c

PURSUIT GUNS		LEWIS GUNS	
3/4" Long 3c	1" Long 4c	1 1/4" Long	10c
1 1/4" Long	5c	1 3/4" Long	10c

AXLE Fork and Swivel Joint	
1/2" up to 5/8" wheel	10c
3/4" up to 7/8" wheel	15c

AXLES Threaded and fitted with washers, bushings and nuts.	
Lengths 1/10 3/32 1/8	
2" 3" 6" 12" 18" 24"	
7" 8" 9" 14" 18" 23"	
10" 11" 12" 18" 15" 23"	

SELLEY MFG CO. INC., DEPT 107B 1373 GATES AVENUE, BROOKLYN, N. Y.

DEALERS JOBBERS DISTRIBUTORS MANUFACTURERS

ANNOUNCING NEW CONFIDENTIAL PRICE LIST

and now . . . SELLEY offers the Largest range of authentic model AIRPLANE and BOAT parts and Fittings at New Low Prices.

ACT QUICK: Write for particulars about this sensational offer. Only legitimate dealer letterheads will be recognized.

—THEY ADVERTISE—LET'S PATRONIZE—

Drome of the Bat Staffel

"Switch off all lights!" Hardly had that spurious order been obeyed when out of the black of night a frightful flame lashed down upon that Yank drome, consumed a score of pilots in a horrible fiery death, and reduced their planes to charred cinders. What was this terrible scourge that found its strength in darkness? The quest of that mystery was destined to put Captain Philip Strange at the mercy of his worst enemy, was destined to make him a victim of brutes who feared nothing—nothing except light!

* * *

CHAPTER I

THE INVISIBLE FLAME

A TINY red light was all the girl could see in the blackness of the hall. She paused, trying to accustom her eyes to the gloom, but the darkness was impenetrable. Silently, she groped her way along. As she neared the light she could see a heavy bronze knob beside it. Muffled voices came through the closed door.

She hesitated, as though unwilling to enter, then reluctantly reached out a slim hand toward the knob. But just at that moment, she heard voices within.

"*Jawohl, Excellenz,*" a man said in a tone of gruff deference. "I understand the orders. But what was this warning you were going to give me?"

"Merely a word about *Fraulein Doktor,*" a voice answered. There was something sardonic under its smooth cadences.

The girl swiftly drew back her hand. Her dark eyes stared at the door.

"She is not to be told of these final steps," the suave voice continued. "It might destroy her usefulness."

"You think she'd turn squeamish?" growled the first German.

"That is part of it," admitted the man he had called *Excellenz*. "She lacks cold-bloodedness, though hatred for the French carried her through for a while. Her parents were wrongly shot as spies in those first confused days of '14."

The girl's face shadowed. She stood, waiting, with the dark red light shining upon her.

"It was a good thing for the Fatherland," the too smooth voice went on. "Young as she is, she has an unusual talent for espionage. As head of the spy school at Antwerp, she is brilliant. But in the last year, since the Americans came in, she has lost a number of special missions. Most were in connection with that *Teufel* I just mentioned—Captain Strange."

As though from an electric shock, the girl's slender form stiffened. She bent over, listening intently.

"Well, she is not the only one he has tricked," she heard the other man grunt.

"Is that a jibe at me?" The senior German's voice was icy.



Illustrated by Eugene M. Frandzen

"*Nein, Excellenz,*" came the hasty reply. "I was only thinking that he must really be part devil."

"I am not afraid of him," the second man said tartly. "Nor is *Fraulein* von Marlow a coward. But this man Strange at times possesses an unusual mental power, and it seems to render her helpless."

"Then it is true he is a mind-reader?" the girl heard the gruff man ask.

"Within close limits," came the impatient response. "I knew him on Broadway before he ran away from the uncle who was exploiting him as a juvenile prodigy. He usually requires a quiet scene for hypnotism or telepathy, and since crossing his trail in the war I have twice misled him by purposely thinking along a false track."

"*Sehr gut,*" chuckled the gruff-voiced Boche. "But after tonight you need not worry about him."

"No, thanks to this information from one of the *Fraulein's* agents. But here is the alternative scheme, if the other goes wrong. . . ."

As the girl listened to the plan, her face slowly paled, until in the red glow it was like a white but beautiful cameo set against a ruby. A minute passed while she stood there. Once a moan came to her lips, but she stifled the sound. Then the voice of the senior man abruptly altered, and she knew the conference was at an end.

Unsteadily, she moved back from the door. As the red light fell upon her hands she shivered. They were a gruesome color. It was like a grim symbol . . . the blood of Philip Strange on her hands . . .

"No, no!" she whispered wildly. "Oh, God—don't let it happen!"

Blindly, she turned away and was lost in the blackness of the hall.

SENSATIONAL "PHILIP STRANGE" MYSTERY

By Donald E. Keyhoe

Author of "Squadron From the Grave," "Staffel of the Starved," etc.



Suddenly, the air reverberated with a weird whirring. Then out of that pall of blackness, fearsome, batlike shapes plunged. Before Philip Strange could reverse, two luminous streams struck the left wing of his Spad, enveloped it in flames.

FOR the third time, Captain Strange signaled for lights, but there was no response from the Chaumont field a thousand feet below. He waited a moment, then sent the borrowed Nieuport whining down in the darkness. The night was black, for heavy clouds at two thousand feet obscured the stars. He made the landing half by instinct, half by skill. As the ship rumbled to a stop on the G-2 side, he saw a row of planes and a little group of pilots nearby.

He switched off the engine and jumped to the ground. Two of the pilots ran toward him. He was surprised to recognize Tom and Noisy Jay, his twin aides, as their faces became visible in the gloom.

"What's the big mystery, Phil?" Noisy burst out. "It'd better be good, to haul me away from a swell date like—"

"Hold on!" Strange said sharply. "What are you driving at?"

"Why, your message for the whole G-2 air unit to

be out here," exclaimed Noisy. "You said—"

"I didn't send any message," Strange cut in. "I came here from Paris on a code flash from Colonel Jordan."

"But he was the one who sent us out here!" said Tom excitedly. "He said you'd sent him a message that something had happened you couldn't explain—to have all G-2 pilots out here and ships on the line."

Strange shot a quick look along the dark tarmac.

"Why are all the lights out?" he demanded.

"It was part of that same message," Tom replied in a tense voice. "It said to shut down the Hanlon Field power plant until you arrived—not even to show flares, no matter who signaled."

"The whole thing's a trick," Strange said swiftly. "Noisy, find the O.D. and have the dynamos started again. Tom, tell the others to meet me in the office. I'm going to phone Jordan."

The Jay twins dashed away, and Strange hurried to the rambling, iron-roofed building which served as the field headquarters. Only dim candle-light showed as he opened the door. He almost bumped into the engineer officer, a plump-faced lieutenant named O'Rourke, who, like almost everyone in Chaumont, knew him by the pseudonym of John Neville.

"I was just coming to look for you, Captain Neville," O'Rourke said hastily. "Paris G-2 wants you on the phone—said every second counted!"

The G-2 ace strode inside, then turned abruptly, his eyes narrowed.

"O'Rourke, something's about to happen on this field!"

The other man started.

"What do you mean?" he said anxiously.

"I haven't any idea what it is, but we want lights as fast as we can get them! Lights, and men with guns!"

O'Rourke fired an order at an open-mouthed messenger, then disappeared outside, shouting for the sergeant-of-the-guard. Strange

spoke briefly to the switchboard man, was entering the nearest office when Tom Jay and the other G-2 pilots came in. He motioned them to wait, went in to the extension phone. "Neville!" he said. "What is it?"

"One moment," a muffled voice answered. "Colonel Williams has an important order for you—he is on another line just now."

"I'll wait," said Strange. But instead, he jumped to the door, beckoned to Tom. "Stay on that phone," he whispered. "Don't say anything unless they speak first, then tell them you're Neville—carry it through!"

As Tom, somewhat dazed, took up the phone, Strange hurried to the switchboard.

"Get me Colonel Jordan—then trace that other call," he clipped at the uniformed operator.

As the man seized a plug, the drone of an Hispano became audible from up in the night. It became louder, broke as the pilot signaled for landing lights. Strange cast a quick glance at the clock.

"Must be the Senlis courier," he muttered. "They could hardly have repaired the Spad in this time."

The operator swung around, a puzzled look on his face.

"G.H.Q. doesn't answer, sir. I've tried every line but the one hooked up with Paris."

The last words boomed out as the roar of the Hispano abruptly ended. Almost in the same moment, a queer scraping sounded just overhead. Strange stared upward. It sounded as though something were crawling or sliding along the iron roof.

One of the G-2 pilots turned quickly toward the door. Strange whirled for a hasty warning, but the words never left his lips. For as the odd scraping ended, a frightful scream rose from outside the building. The man who had sprung to the entry jerked open the door, then leaped back with a gasp of horror. Strange took one look, and his blood seemed to freeze in his veins.

A terrible figure had staggered into view. Its face was a charred brown mask—but it was the face of O'Rourke!

Even as Strange looked, that brown horror deepened into black, as though an invisible flame writhed across the man's face. O'Rourke clawed madly at his eyes, his dreadful screams echoing through the night. Then suddenly his knees gave way, and he tumbled in a heap. The charring blackness spread swiftly over his shoulders and on down his back.

FOR that first awful instant, Strange had stood paralyzed like the rest. Now he jumped toward the water-cooler.

"Give me a hand!" he rasped at the nearest man.

But as they swung it down, the cover fell off and he saw that the tank was empty. He whirled toward the next office, then realized it was too late. O'Rourke had ceased to shriek, and even as Strange spun around his blackened figure gave a final convulsive twitch and was still.

From out on the drome came other screams of agony, but above the cries Strange heard the brief howl of a plane diving toward the field. With a terrific crash, the ship struck. Through the opened door a geyser of flame was visible as the wreck blazed up.

The glare lit a dreadful scene. A score of mechanics and sentries had already been stricken down by that weird, invisible fire that had consumed O'Rourke. They were like blackened scarecrows sprawled around the tarmac, two or three still feebly kicking in their death-throes.

Tom Jay had abandoned the phone at O'Rourke's first outcry. As he saw the charred figures scattered along the line he gave a strangled groan.

"Noisy! He was out there!"

Strange dashed after him as he ran toward the first gruesome form.

"Wait! It might kill you, too!"

"You think I care, if it's got Noisy?" Tom said fiercely.

Strange caught up as Tom Jay reached the first blackened corpse. Just then there came a shout from the direction of the shops.

"Tom! For God's sake, don't touch him!"

Tom wheeled with a cry of relief.

"It's Noisy! Thank heaven, he's safe!"

"Come on," rapped Strange. "No telling when it may strike again."

They reached the door of the power-plant hut in a fast sprint. Noisy jumped aside to let them in. His face was white and drawn by the light of the lantern he was holding for two electricians.

"Did you see what happened?" Strange asked tautly.

"Only the last part," Noisy said in a strained voice. "I don't know what killed them—or where it came from. The first we knew was when the screams started. Three or four men dropped all at once, there by the ships. I started over with the lantern, then I saw two men who touched the others get it the same way."

The gas engine which drove the first dynamo sputtered into life. Strange took a quick look outside, turned to one of the electricians.

"Cut in the line to that first searchlight."

"You going out there?" said the man, amazed.

Strange nodded.

"Whatever it was, it seems to have stopped now."

He reached the light unit a few seconds later, with the Jays following in spite of his hasty order to remain. He switched on the current, and a huge white beam stabbed along the line.

"Look!" said Tom. "It's wiped out half of the ships."

Strange moved the light across the G-2 planes. The one nearest the main group of corpses was a charred and blackened derelict. The next Spad had its right wing and fuselage burned, but the left wing was almost intact. Farther on, where five or six enlisted men had fallen, two more Spads had been practically destroyed. Their wings were gone, and only cinder spots on the ground showed where they had burned off and dropped. The two fuselages were black skeletons. But, oddly, not a trace of smoke arose from the ruins.

It had taken only a moment to reveal the destruction. Strange quickly swerved the beam over the shops and barracks to the office building. Some of the G-2 pilots were already outside, running toward the searchlight. He lifted the beam, swept it over the office. There was nothing on the roof.

BY this time, one of the electricians had turned on a second searchlight. The powerful beam crossed and recrossed the sky, but only lowering dark clouds were to be seen. Strange looked around at Noisy.

"Could you hear anything after that ship crashed?"

"You mean Boche? No, not a sound."

"They couldn't have seen to do it, anyway," Strange muttered, staring up at the Stygian clouds. "My eyes are as good as the next man's, and it was so dark I almost cracked up on that landing."

Noisy looked at the black things which had been men.

"Poor devils!" he said with a shiver. "What could have done it?"

Strange shook his head, turned as the Intelligence pilots reached them. The first man was a plump little Kansan named Ball.

"Are you all right, captain?" he panted. "Some one at Paris wants to know right away."

Strange's lean face hardened.

"So they're that anxious, are they?" He looked grimly around the ring of tense faces. "Knapp, take three men and get those other searchlights turned on. Keep them moving so the field is constantly covered. Noisy, you and Tom come with me. The rest of you spread out and try to keep the enlisted men from getting panicky."

"Some of them have already run for it," vouchsafed Ball, as the others hurried away. "They got the idea



that something invisible was here on the field, and it might kill them any second."

Strange saw him look nervously toward the office.

"Don't tell anyone else about that sound on the roof," he said tersely. "Pass the word to the others."

As Ball disappeared, Strange turned to Noisy.

"See if you can tell whether that crashed ship was a Spad. We'll be at the office."

More lights blazed out as he and Tom returned to the hutment. Several men, caught in the beams, hastily ducked for the shadows. Strange saw a number of them running for the main gate. There was no sign of the sentry, but he heard the O.D. and some of the non-coms yelling commands and trying to restore order. Tom stared at the scattered bodies between the line and the office.

"I don't blame those men for deserting," he said huskily. "I'd like to get away from here myself."

Strange was watching the probing searchlights.

"I think we're safe for awhile," he said absently.

"Then you've an idea about it?" Tom exclaimed.

"No, but whatever it is, it doesn't seem to work except in the dark," Strange answered.

He gave O'Rourke's body a pitying glance as they went into the office. The operator was talking excitedly into his mouthpiece.

"Here's Captain Neville now," he said. "It's Colonel Williams," he told Strange in an aside.

"How much have you told him?" Strange asked sharply.

"Why, everything, sir—he asked—"

Strange snatched up a phone from the first sergeant's desk, and the operator made the connection.

"Captain—Neville?" said a queerly hoarse voice. Strange could tell that it was disguised.

"Listen, you damned butcher!" he snapped savagely.

"I don't know who you are, but when I find you, by Heaven—"

There was a gasp, a click, and the line went dead.

CHAPTER II

NURSE AND NEEDLE

TOM and the operator were gaping at Strange.

"Good gosh, cap'n," said the switchboard man, "that Brass Hat'll have you broke to a buck private!"

"Your Brass Hat is a German spy," Strange retorted grimly. He left the man with his jaw sagging, went out and bent over O'Rourke's charred body. Tom followed, watched curiously as he took a sliver of wood and touched it to one cindered hand. There was no result.

As he straightened up, Noisy appeared. "You were right," he said, "it was a Spad."

Strange gazed toward the smoldering wreck. "Have they removed the pilot's body?"

"They were just dragging it out." Noisy grimaced, his eyes on O'Rourke's blackened figure. "Couldn't tell who he was—he looked just about like this."

Strange slowly nodded. "They both were burned to death."

Noisy stared down at the corpse. "But there wasn't any fire when he and those others were killed."

"There was fire, all right," Strange said in a hard voice. "But the flame was invisible. We could see O'Rourke's face scorch as the fire burned across it."

The strident blare of a klaxon horn suddenly sounded from the Chaumont highway, and a big Staff car swung in through the gate. It stopped nearby, and a chunky colonel jumped from the rear. Strange recognized the heavy, bulldog features of the chief of G-2, Colonel Ira Jordan.

"Strange!" Jordan exclaimed with a note of relief. "Then it wasn't your ship—" he looked down at the

charred body, and a sick expression came into his eyes.

"Lieutenant O'Rourke," Strange answered his unspoken question.

"I was afraid it was you," Jordan said, in a shaken voice. "You hadn't called, and I knew you were due any minute. Then I heard the crash, and I couldn't get any one by phone, so I dashed out here."

He tore his eyes away from the body before him. Strange glanced at him soberly.

"O'Rourke wasn't killed in the crash, colonel. Take a look down the line."

Jordan swung around, turned pale with horror.

"Good God! What killed them?" he whispered.

"We don't know," said Strange. He briefly explained how the mysterious death had struck. "But that isn't all. That message you thought I sent was false. I also received one in 'L' code, supposed to be from you and



telling me to leave Paris and fly here at once. If it hadn't been for a lucky accident, the entire G-2 air unit would be out there dead, instead of those poor wretches. My radiator developed a leak soon after I took off from Paris. I landed at the 48th *Escadrille* and argued the C.O. out of a Nieuport."

"Holy smoke!" said Noisy Jay. "So that's why you wanted to know about that ship."

"Exactly," said Strange. "Whatever this invisible fire death is, it was evidently intended to strike just as I was landing. The message to the colonel was designed to get all the G-2 pilots out here on the line, expecting immediate orders. We'd all have been killed if I hadn't been in a Nieuport. Evidently the Spad from Senlis was mistaken for my ship—the course is almost the same as that to Paris."

During the explanation, Jordan's horror had slowly changed to wrath. As Strange finished, he wheeled toward the office.

"By Heaven, I'll crucify Communications for this!"

"All the lines from this field are dead," said Strange.

"They were probably cut between here and town."

"What about the one with that fake Paris call?" asked Tom Jay.

"It must have been made with a lineman's set, hooked on where they cut the wires," Strange replied. He was explaining to Jordan about the incident when a dozen cars came racing out from the little Headquarters town. The first was a Staff machine filled with officers. Two ambulances followed, and behind them came several cars with Army doctors and nurses. Strange halted the first Army surgeon he saw.

"How did you get word of this?" he asked quickly.

"Men from here dashed into town and gave the alarm." The medico stooped over O'Rourke's body. "Why, this man's been burned to death. They said some kind of plague had struck the field."

STRANGE beckoned to Tom Jay and left him explaining to the surgeon. Still more cars appeared, some bringing Hanlon Field officers who were quartered in Chaumont. The Jays and the other G-2 pilots were quickly surrounded by an increasing crowd, while the Army doctors began their examination of the dead.

Strange skirted the crowd and went into the office. The building lights were still off, but he found the operator hastily shifting plugs.

"Headquarters linemen found the break, half a mile down the road," the man jerked out between calls. "All the wires were cut."

From the other end of the unlighted hall, Strange heard Jordan bellowing into a phone. He started in that direction, then stopped quickly and looked around. For an instant, he had had a feeling that some one was watching him intently.

The operator was busy, and there was no one else in the bull-pen. He glanced out through the doorway. Two non-coms were passing with a stretcher. Beyond them was an ever-growing crowd. A skinny major hurrying by looked in for a moment. Farther on, Strange briefly glimpsed the Jays talking with one of the nurses.

He went on to the cubicle where Jordan was phoning. It was the next to the last office on the left of the shadowy hall. Yellow light flickered from a candle as he entered and closed the door. The G-2 chief was just banging down the phone.

"Blasted numbskulls!" he erupted. He stood up, then saw Strange glancing thoughtfully toward the ceiling. "Now don't tell me you believe this wild story the operator told me of something invisible crawling along the roof?"

"No," said Strange, "though something did scrape over it just before O'Rourke screamed. It might be a good idea to get a ladder and see if there's any sign of what it was."

"Wait a minute," said Jordan. "They're going to check for that message you got and then call me back."

Strange lighted a cigarette, paced restlessly back and forth. Jordan eyed him keenly, finally spoke.

"What do you think killed those men?"

Strange turned to reply, but the exhaust of a motorcycle parked near the building rose to a deafening roar. In the same moment he caught a furtive movement back in the shadows, as the connecting door to the next office started to open.

He snatched out the .45 strapped at his hip. The door closed as he sprang, but he jumped to one side and booted it wide open. The door swung inward against a desk, narrowly missing a vague figure there in the darkness. Strange stared. It was a girl in Army nurse garb.

Before he could reach out to draw her into the light, there was a commotion behind him. He whirled. Two men in sergeant's uniforms had leaped into the room from the hall. One of them viciously rammed a gun into Jordan's stomach, cutting off the colonel's attempt at a shout. The G-2 chief doubled over, the breath driven from his body, then fell to his knees.

Strange, instantly covered by the second man, had raised his hands. The false non-com reached up to snatch the .45. With a lightning sweep, Strange slashed the heavy pistol against the man's head. The spy's gun spurted flame as his finger spasmodically jerked the trigger. But the blow had thrown him off balance, and the bullet drilled into the wall.

As the spy tumbled to the floor, Strange spun toward the other man. But the nurse ran out from the other room, and the muzzle of a gun was swiftly pressed against the back of his neck. He froze, and the second spy hastily seized his pistol. Apparently at a signal from the girl, the man closed the hall door

and then ran to the window. Pulling the shade aside, he motioned to some one. The roar of the motorcycle lessened to a drone.

JORDAN had slumped across the unconscious man, his face ashen. The other spy looked at him, then turned, glaring over both guns at Strange. The muzzle at the back of Strange's neck was at once withdrawn. From the corner of his eye he could just barely see the girl in nurse's attire. She seemed to be taking something from under her cloak. He turned his head.

"Stand still!" grated the false non-com. He thrust both guns against Strange's chest, but it was too late. Strange had already seen the girl's face. As he recognized Karol von Marlow, a stunned incredulous look came into his eyes.

"You!" he whispered.

For a fleeting instant, Karol's face held a haunted expression. Then her curving red lips hardened.

"Yes, you have tricked me for the last time, Captain Strange."

He gave her a long, unbelieving look, slowly shook his head. The spy with the guns spoke nervously.

"Hurry, *Fraulein*, some one may come."

Strange stared down at the hypodermic needle in the girl's hands. The stricken look in his eyes deepened, then his mouth twisted into a bitter smile.

"I congratulate you on so easily forgetting our happy days together before the war."

She bent over the needle, then looked up with a scornful laugh.

"You are not dealing with a foolish young girl now, captain. I am a German agent, and you are an enemy of the Fatherland."

"Please hurry, *Fraulein*," the man covering Strange urged anxiously. "Even after he is unconscious, I will have to get help, now that Hans has been knocked senseless."

It was then that Strange realized the spies were the two non-coms he had seen with the stretcher. He looked down at the guns jammed into his ribs. Deliberately ignoring the man, he gazed back at Karol. Her head was again bent, and she was hastily pulling up his left sleeve.

"It is unfortunate," he said ironically, "that your first plan did not work. It would have saved you all this trouble."

"Keep still!" snarled the man before him. But Strange went on as though the Boche did not exist.

"I also apologize for calling you a butcher. If I had known then it was a woman, I would have said—a Borgia."

She looked up, a queer, mirthless smile on her lips.

"One of your mental powers seems to have failed you tonight. But perhaps it is as well."

She grasped his wrist firmly, slanted the needle against his forearm. Then for one last second her dark eyes rested on his face.

"Goodbye, Captain Strange!" she said in a suddenly trembling voice. The hollow needle plunged into his arm.

He gave a violent jerk, and the delicate tube snapped, leaving the tip buried in his flesh. The contents of the syringe were sprayed harmlessly into the air.

"*Schweinhund!*" rasped the false sergeant. He lifted the .45 to crash it down on Strange's skull.

"No, no!" cried Karol. "I told you—*Watch out!* The colonel!"

Jordan was staggering to his feet. The spy jumped back, trying to watch both men. Strange had already tensed to ward off the blow from the gun. As the spy's gaze flicked toward Jordan he gave a tigerish leap.

(Continued on page 59)



Snapshots of the War



Above: Here's something to start an old argument all over again. It's a French Nieuport used by our Army Air Service in France—but note that U.S. star insignia under the left wing! We've always been told that this insignia didn't come out until after the Armistice, yet we have it on good authority that this picture was taken in France before that date. Now, who can "put us right" on this question? Left: This is a rare photo of a little-known ship—the Siddeley RT7, a two-place British fighter that mounted the Siddeley "Panther" engine. It came out too late to be of any use in the War. (Puglisi photo.)

We have shown pictures of the famed Georges Guynemer before, but we believe this is the first time you've seen this one. It shows the incomparable French ace as he really looked at the peak of his career. One would never take this pleasant-visaged man to be one of the greatest sky fighters of the Great War.

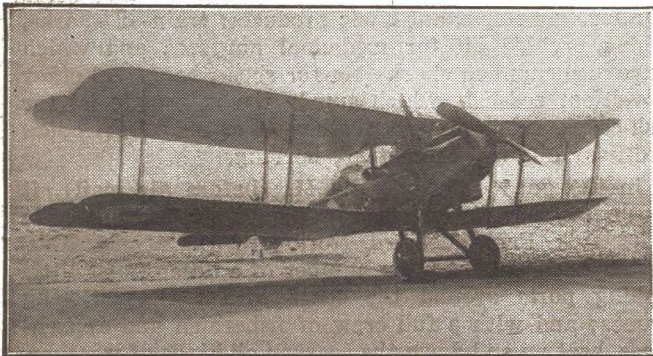

Below: You can't say we don't give you a variety of ships! Look at this old Bristol Braemar. This was a bus built for the bombing of Berlin, and it would have been done, too, only they signed the Armistice too soon. A wicked looking triplane! (Puglisi photo.)

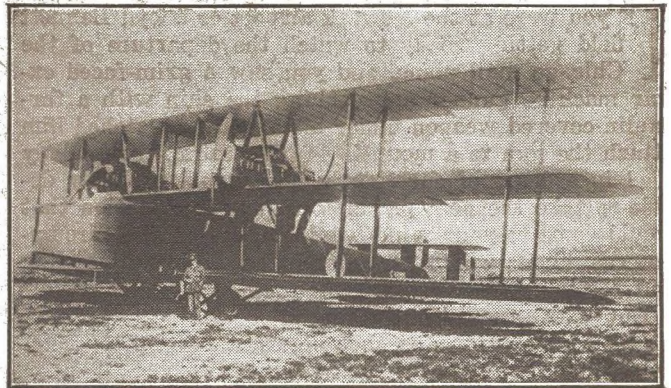
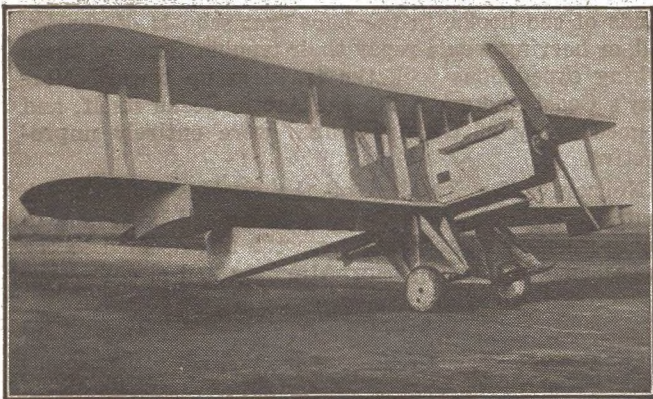

Above: And here we have an unusual "shot" of the Short Skiri, a noted Royal Naval Air Service job used for torpedo bombing. Note the pontoons under the wings—just in case they did come down on the water. (Puglisi photo.)

Right: This unfortunate Breguet, assigned for use by the Americans, did a somersault when a landing was attempted in a field of tall grass just behind the lines. We'd like to know who flew this plane and to what squadron it belonged. Perhaps one of the mechs in the picture will remember and write in and tell us. Anyhow, it must have been some job straightening it out!



Iceland's Shark-Shooting



Meet Ivor Neilsen, director of Iceland's air company and "father of the aero fish-patrol." Foresighted and enterprising, he gave a unique air mail service to this land "which hangs on the edge of the Arctic Circle."

By Charles S. Strong

IF you were at the Newark airport or Floyd Bennett field getting ready to watch the departure of the Chicago mail plane, and you saw a grim-faced ex-war machine gunner approaching the ship with a tarpaulin-covered weapon under his arm, and watched him attach the gun to a mounting in the cabin, then calmly feed in a drum of cartridges—you would probably decide to take the next plane. The only explanation that would come to your mind would be one of dire circumstances, about which the pilot had received a warning and for which he was making preparations.

But ex-war machine gunners on the Icelandic Air Mail have no such significance. Up there, machine guns are just part of the job, and I think the story of their use is mighty interesting.

Hanging up on the edge of the Arctic Circle, and harboring only about one hundred thousand people, Iceland is in no position to pay subsidies to prospective air mail companies as its wealthier neighbors, such as the United States, England, France, Holland, etc., are able to do. If Iceland wants air mail, it has to pay for itself. And as a potential stopping place for a Europe-America northern-route transatlantic air mail service of the future, the Icelanders were naturally anxious to see what they could do about air mail for themselves.

One solution would probably be for everyone in Iceland to write air mail letters every

A machine gun is standard equipment on Iceland's air mail plane; but it's not to protect the air mail—it's to protect the fish! In this bang-up feature—a fish story that's every bit fact—you'll learn why. Excitement, Mr. Strong tells us, is the daily fare on this far-north mail run—and he ought to know, for he's made the trip.

✱ ✱ ✱

day that the plane goes out; but unfortunately a good many of the people in Iceland don't know how to write, and those that do are probably quite busy with other matters a good deal of the time. But Ivor Neilsen, enterprising director of the "Flugfelag Islands" (Iceland's air company), found a way to solve the problem.

He simply capitalized on Iceland's current industries, adding improvements that only air service could provide. To those readers who are not familiar with Iceland's industries, I will point out that they have three particularly important basic products: train-oil sharks, which provide oil for medicinal purposes and which have also supplied shark-skin for shoes, bags, and other novelties; cod-fish, which supply the raw material for fish-cakes, salt fish, and (believe it or not) Norwegian cod-liver oil; and last of all, herrings.

In the good old days, B.A.M. (before air mail), it was customary for large steam trawlers to put out from Reykjavik, Faskrudsfjord, Nordfjord, Siglufjord, Akureyri, Eskifjord, and any number of a dozen other little fishing ports around the coast with tongue-twisting names; and with a full crew of fishermen and apprentices, beat up and down the coast in all kinds of weather, often putting out a dozen boats, and dropping thousands of cod hooks, in the hope that schools of sharks, cod, or herring would repay their trouble. Some of these fishing expeditions took the trawlers up toward Norway's Coast and even into the Arctic Ocean itself, and a good many of these ventures were entirely unproductive.

Neilsen, after hearing of the success with which British seaplanes over the North Sea had been able to locate German submarines from the air, decided to try the scheme in locating fish. Attempts had already been



How would you like to fly a regular run along this bleak, rugged coast? Well, that's the job of Pilot Baldwin, about whom Mr. Strong writes in this dramatic article. The photo shows a wind-swept headland near Skaptaros, on the south rim of Iceland.

Air Mail

made on a small scale off the coast of Norway and in the Bay of Biscay, but these were intermittent and without outstanding success. But a few trial flights around Reykjavik developed the fact that it was entirely practical to scout for fish in this way, and that the denizens of the deep might be seen on reasonably clear days even on the bottom of the ocean if the plane were not too far out from shore.

The plan developed so much interest that an English, a German, and a Norwegian air company all made bids for the opportunity to supply equipment and men. The Icelanders finally decided to use a Junkers cabin plane. For the first year they employed two German pilots, but later they substituted their own after one had gone to Germany for training and another came to the Curtis-Wright School on Long Island. Even after this decision was reached, an English Company still flew survey flights about the coasts and nearly developed international complications, since the rumor was heard that "England was going to fortify Iceland."

UNDER the final arrangement, the Junkers was equipped with a two-way radio outfit which was lined up on a short wave length with fishing bases around the coast. Upon discovery of a school of cod, herring, or train-oil sharks, the message is radioed to the nearest base, and the plane then continues to "spot" the fish until the trawler, or trawlers, arrive. This has had a number of advantages, since it practically assures a catch on every trip—unless the fish get out into deep water (which they seldom do, since they feed on the shallow banks).

Out of each catch of fish, a certain percentage is reserved for the air company as "commission." This more than makes up for the lack of letter-writers! Another duty of the air mail plane which brings an income in the form of salvage "prizes" is that of aiding trawlers, which because of unusual natural conditions, are occasionally wrecked upon the coast of Iceland.

Let us get right up close to this business and see how it works out. When I was in Reykjavik recently, I became acquainted with the complete operation. Like yourself, the first question that came to my mind was, "Well, what are the machine guns for?" When I discovered that they were used against sharks, I immediately visualized a huge threshing mass of man eaters

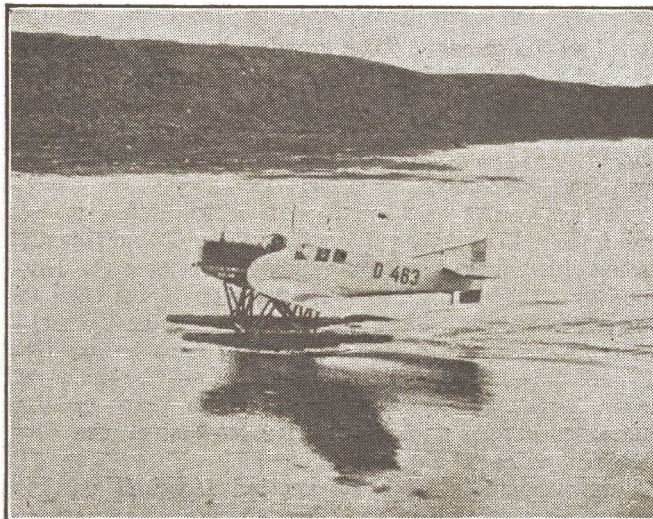

And here is the D463—Iceland's air mail and fish patrol Junkers. The author describes a thrilling attack made in this seaplane upon an army of man-eating, train-oil sharks.

just waiting to be shot. But more of that later.

The air mail plane begins its journey around the long coast-line from a mooring buoy beyond the deep-sea mole in Reykjavik, Iceland's capital. We stepped off the dock into a speedboat which headed for the fjord (inlet from the sea) where more than a thousand years ago a little thirty-foot boat arrived with a crew of roving Norsemen. Swinging at the buoy, where it bobbed to each eddy of the tide and any wash of a passing ship, was the trim outline of a Junkers monoplane. Painted on the sides was the inscription "Flug-felag Islands D 463." It was ready for action. The pilot preceded me into the cabin, the machine gunner waited behind to take the gun from the tender man, and finally we were all settled. The propeller was already spinning, and soon the steady drone of the engine settled itself in my ears.

Pilot Baldvin settled himself at the controls. The machine gunner was busy mounting his gun. The nose of the ship swung around and the plane taxied down the fjord beyond the deep-sea mole. Into the wind it swung, then picked up momentum. With scarcely the sensation of a jump we were in the air. The Icelandic Air Mail was off on its usual trip of 4,000 miles along the coast line of this little known sub-Arctic mail route. Yet all of the letters aboard might easily have been carried in one of the pockets of my coat with quite a bit of space to spare.

I turned to Jon, the gunner. "Is there any particular place where you look for the fish?"

"Well," he told me, "you can be pretty sure of the cod and herring, but you are liable to find the sharks anywhere. The codfish banks are mostly on the southeast coast of the island, and are just about at the edge of the Currents. (Yep, the good old Gulf Stream.) The herrings are all on the northeast and northerly coast. In this way, it is pretty easy to keep the herring boats near enough to those banks, and the cod boats within easy reach of the cod banks, so that the plane is not delayed for any great length of time."

A flash on the receiving set suddenly brought a response from Jon. I was told that the messages were intended for various fishing stations, informing them that the plane was in their "district." Then one of the messages galvanized Jon into action!

Baldvin received it on his head set,



Water spouts have wrecked several trawlers on the rocky shores of Reykjaness, and here's all that remains of one of these ill-fated vessels. Loss of life in these disasters has now been minimized through quick rescue action by the air mail flyers.

turned to the gunner. "The trawler, *Helgi II*, is going up on the coast of Reykjaness." Jon turned from his gun, picked up a pair of field glasses. I wondered why the *Helgi II* didn't keep away from the rocks at Reykjaness. The day was clear and there did not seem to be any particular reason for a wreck.

"But they can't help it," Jon explained. Then as we circled over Reykjaness I learned why. I could easily discern the burning volcanic area that effects the surrounding waters. Under-water eruptions from time to time cause water spouts that periodically drive the luckless trawlers up on the shore. In the days before the air mail this meant that all members of the crew of such a boat might be lost, or starve to death on the bleak cape before another trawler learned of the disaster and came to aid them.

A few moments later we spotted *Helgi II* on the eastern coast of the cape. It had gotten in behind the sheltering arm of land, but was in shallow water.

Pilot Baldwin pulled the plane into a cove that was sheltered from the tidal swell of the water spouts. Still the Junkers bobbed up and down like a cork on a high sea. The three of us jumped out of the plane into the shallow water and waded to the beach. The captain had dropped both anchors as the ship came up on the sand. He answered Jon's "hallo" to the ship, and requested that the plane notify Reykjavik, since his sending equipment was not powerful enough to reach the Icelandic capital. Satisfied that everything else was all right, we returned to the plane. Baldwin took off while Jon sent the necessary message. The Iceland air mail had earned its first fee for the trip!

After things quieted down and we headed up the coast, I was assured that this was by no means an unusual circumstance; the number of wrecked ships which I spotted high and dry on the cape, which had not been as lucky as the *Helgi II* testified to the truth of these words. (*Helgi II* finally went to this graveyard itself on a later trip).

JON now pointed out that we were in the cod waters. We were moving up the coast from Vik, the southernmost point in Iceland, and when we passed to the south of the broad Vatna Jokul (glacier) we sighted a breaking of white water off the coast. Immediately the Junkers veered from its course and circled out to sea. With every moment we were coming nearer and nearer to this strange sight. Then suddenly the water lost its movement, and the calm bosom of the sea was all that presented itself to us. I thought to myself, "whatever it was, cod or sharks, it has gotten away from us."

As though to disagree with me, the radio started to crackle. Knowing something of the code, I realized that a message was being sent to Westman and Hornafjordur. These were the two nearest fishing ports. As we moved over the position, my gaze was riveted on a black shadow below the surface of the water that was moving off to the eastward. At first I misinterpreted this as the shadow of the plane on the water. But it turned out that the "eye" of the fishing fleet had located a large school of codfish and was tracking the bank until the trawlers from Westman and Horna-

fjordur would arrive. We kept circling, and finally, after some little time, I discovered a trace of smoke on the horizon to the eastward and another to the westward.

"Can't we go on now?" I asked. "The trawlers are in sight."

"The trawlers may be in sight," was Baldwin's reply, "but they would not be able to find those fish unless the school comes nearer to the surface. They are down quite a ways, and the chances are that the trawlers would steam right over them without knowing anything about it. That is an advantage of the airplane in fishing."

Not long afterward that school of cod was on ice, and Baldwin made a second note on his log. The Iceland Air Mail had earned a second commission! The machine gunner signalled farewell to the trawlers by radio, we

dipped our wings in salute, and could almost see the grim smiles of satisfaction on the faces of the two rugged trawler captains as they lowered and cast off their boats to go after the catch. What a difference from the chagrin of a futile seven-day run for nothing, which marked the old days!

Jon pointed to one of the cliffs close by and smiled. "It was off here," he told me, "that we picked up the Swedish transatlantic flyers a few years ago. We radioed to the government patrol boat and they came out to transfer them so that we could go on our way." I well recalled the incident, since it was front page copy in all the newspapers. Jon then described how the D 463 had once acted as escort to the *Graf Zeppelin*, and was host on a short flight

for the Lindberghs on another occasion.

But the regard with which the air mail crew are held was really indicated when we reached Siglufjordur. This is the largest herring port in the world, in spite of its location on the desolate north coast of Iceland. (Hafnarfjordur, the large cod fish port, is above Reykjavik and off the course of the plane.) The plane reported in at Siglufjordur, where we found pile upon pile of fish barrels and industrious young wives and fish girls salting and preparing the catch of the previous day.

When we cleared the point of Skagafjordur beyond the town, Jon tapped me on the shoulder. "You'll probably see something now," he remarked, "the sharks have been playing the devil with the herring schools. We don't mind, though, because it's all money in our pockets."

"Yes," I laughed, "and fish oil in our drug stores." We were not far beyond the point when the second shadow of the day appeared on the water. I could almost visualize the reaction back in Siglufjordur. Merry men rushing up and down the decks, furious activity in the stoke hole, steam bursting from the whistles, and the smiling faces of the women folk as they waved to the men. Anticipating another hour's wait, I kept an intent watch toward Siglufjordur to catch the first glimpse of the trawlers when they came in sight.

There was suddenly a muttered grunt from Baldwin, then the word: "Tren."

I knew that "tren" was the equivalent of train oil. Transferring my attention from the horizon to the water directly below and peering out of the window, I saw fins breaking about a black shadow flecked with silver—

(Continued on page 91)



Here, at Faskrudsfjordur, we see women drying thousands of cod. If it hadn't been for the Junkers D463, these fish might still be cavorting in the sea instead of lying on this slope in preparation for the market.

ACE MCCOY SIMPLIFIED AVIGATION

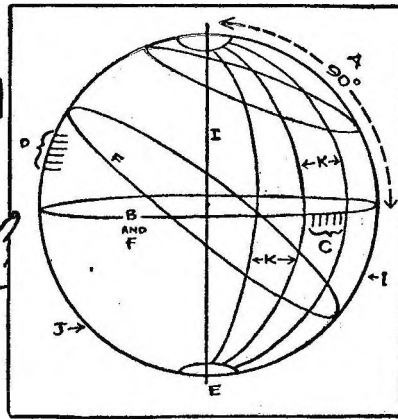

TERMS TO BE REMEMBERED

(See drawing at left.)

- A—Degrees of Latitude
- B—Equator
- C—Meridians
- D—Parallels of Latitude
- E—Poles
- F—Great Circle
- G—Small Circle
- H—Axis
- I—Prime Meridian
- J—Meridian 180
- K—Departure

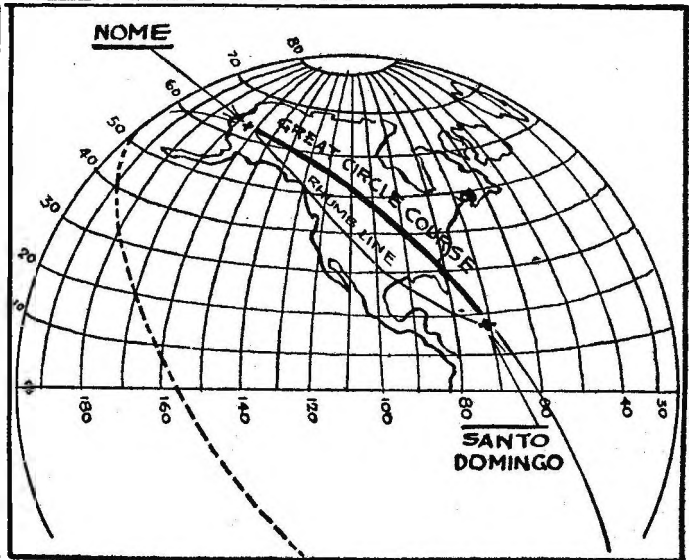
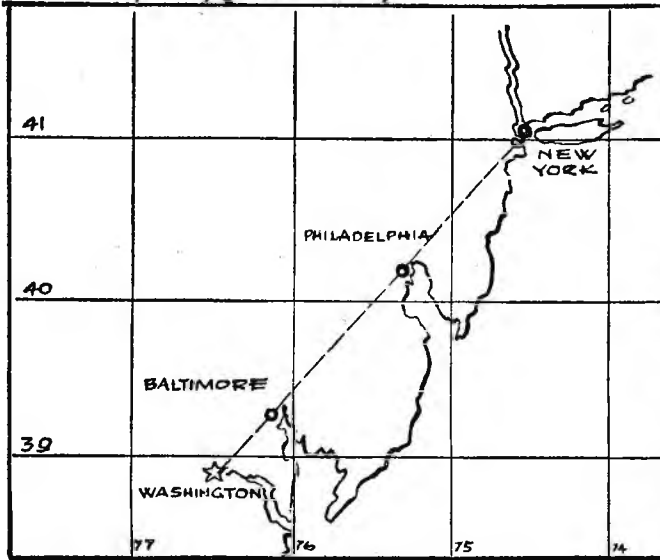

FIRST off, we want to tell you that our *Make Good* course is designated by the shortest line between the point we're at and the point to which we're going. This is called the *Rhumb Line*, and it's drawn on the map (see above) so that it crosses all meridians at the same angle. This is the correct course for short flights. But for long distance trips, the *Great Circle* is shorter.

THE *Great Circle Course* lies along the arc of the great circle joining two points on the globe. It is the shortest distance, upon the surface of the earth, between distant points. It differs from the *Rhumb Line Course* because it intersects each succeeding meridian at a slightly different angle. The two types of courses are shown above connecting Santo Domingo with Nome, Alaska.

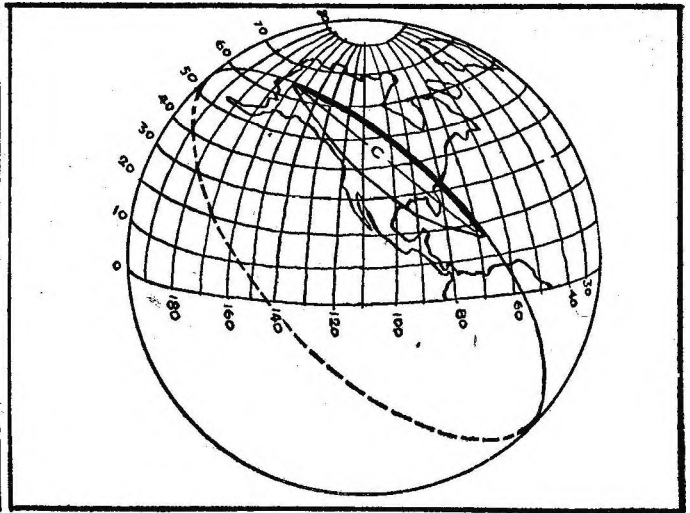
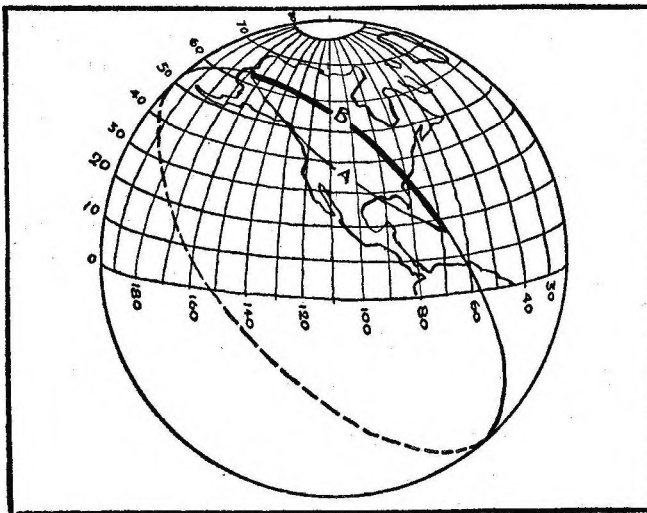

IT may seem to you here that Course "A" (the Rhumb Line) is the same length as Course "B" (the Great Circle). This is because our globe must be pictured *flat* on this paper—but if you'll run a piece of thread over a *real* globe you'll see that the Great Circle Course is the shortest of the two. True, the Rhumb Line would get us to Nome, but the trip would be longer—more round-about.

AND now we connect Santo Domingo and Nome by an imaginary Line "C"—which is the shortest distance of all between the two. But this course would take us right through the earth! And since man hasn't invented any vehicle that'll make that kind of a trip and make it quick, we'll stick to our airplane and the Great Circle Course.

NEXT MONTH'S SUBJECT—MAGNETIC NORTH

Scratch-As-Scratch-Can

ROLLO HAS "COMPANY"—AND NO HOLDS ARE BARRED

ACCORDING to Hoyle, the old authority on the pasteboards of ruination, there should only be one joker in a deck. But the fickle femme known as Fate does not deal her cards according to Mr. Hoyle. She sent the *Rittmeister* Gottfried von Bull over to Bar-Le-Duc one early morning in June 1918. He was in a Pfalz and he was carrying a particularly insulting missive for Lieutenant Phineas Pinkham. Phineas, Public Joker Number One, sat in front of his hut, after a blistering early patrol, striving to teach a certain canine named Rollo to say its prayers. In view of Rollo's apparent age it was fitting that the Boonetown Spad pusher should prepare the subject for dog heaven.

Rollo had come into Phineas' life one day unexpectedly. His ancient frame creaked and there was sadness in the pooch's eyes. Once he was thought defunct after a staff car, loaded with officers, nudged him quite prodigiously. Phineas piled rocks on the supposed remains and departed to mourn. But Rollo resurrected himself, somehow, shook loose his stones, and crawled back to the Ninth one sunny morning. Perhaps his hardihood was due to the fact that not a drop of canine aristocracy flowed in his veins. He bore the earmarks of having been reared close to garbage dumps. Rollo's pedigree, if recorded like that of a horse, would have read: By Ash-

A flank movement by Flanagan started it. Then von Bull horned in. But Phineas knew that a man's best friend is his pooch. And though it isn't news when a dog bites a man, it certainly was when Napoleon, Josephine, Danton, and Dubarry sunk their incisors in poor Rollo.

can out of Dark Alley. Rollo could only have drawn a blue ribbon by being exhibited in a group of unkempt jackals. But Phineas Pinkham and Rollo became closely attached and the canine found sanctuary on Major Garrity's hectic drome.

When Joker Number Two roared over the drome, the pooch laid back its ears and yipped on a minor note. Von Bull's Pfalz spattered the hangars with lead and ventilated the north wing of the Pinkham hut before zooming into the ozone and heading back toward Germany. An obliging groundhog picked up the message dropped by the *Rittmeister* but later Sergeant Casey found something else—a package of the finest looking knackwurst that he had ever seen outside a butcher shop. It had been packed with great care and was tied with a blue ribbon. The impact had ripped some of the paper away and the delectable Heinie fodder was exposed in all its brown-skinned splendor.

"Boys!" chuckled Casey. "Von Bull lost his lunch. Well, it's one time I eat somethin' besides stew!" He hurried to the groundmen's barracks and turned the knackwurst over to the cook.

Meanwhile Lieutenant Phineas Pinkham was reading the Kraut's message. When he finished he let loose a barrage of indignation that sent Rollo scuttling into the hut.

"I am lower than a dachshund's undercarriage, am I? I'm a flap-eared, speckled *dumkopf*, huh? You wait, you hunk of Limburger! So you dare me to fight you on Friday at five p.m., do ya? By-y-y—!" The pride of the Pinkhams had never been in higher dudgeon. A curl of smoke seemed to roll up around the collar of his shirt as he stamped into his hut. Rollo eyed him warily from a safe spot under Bump Gillis's cot. When Bump came in, Phineas was still sitting there scheming, a wicked looking revolver in his lap.

"That's a goofy lookin' gun," Bump chirped. "What is it?"

"It's a Frog 77 cannon that was stunted at growth," replied Phineas, squinting through the barrel. "Nobody wanted it so I took it, haw-w-w-w-w! Anythin' else you'd like to know, you gabby washwoman?"

"I would like to know how to commit a perfect crime," his hutmate snapped. "An' git that damn pooch out of here! Ya want me scratchin' all night? Git—git out of here, you Siberian herring hound!"

"Anybody who kicks Rollo gets the same as if he kicked me," Phineas glowered at Bump. "I'm warnin' ya, ya nickel nurser!"

AT noontime it happened! It happened because knackwurst, loaded with black powder, began to sizzle in a pan. There was a terrific upheaval that shook Garrity's pipe out of his mouth as he sat cogitating in his sanctum in the Frog farmhouse. Hunks of lumber rained down upon the pilots when they ran out onto the field. The commissary of the groundhogs' barracks was in quite a mess. A cook was crawling along the ground on all fours as if he were looking for a collar button. An elbow of stove piping dangled over the back



"M-Monk Flanagan!" Phineas gulped.

ANOTHER ROLLICKING "PHINEAS PINKHAM" ROAR

By Joe Archibald

Author of "Sky Finance," "Smells, Spells, and Shells," etc.

With Illustrations by the Author

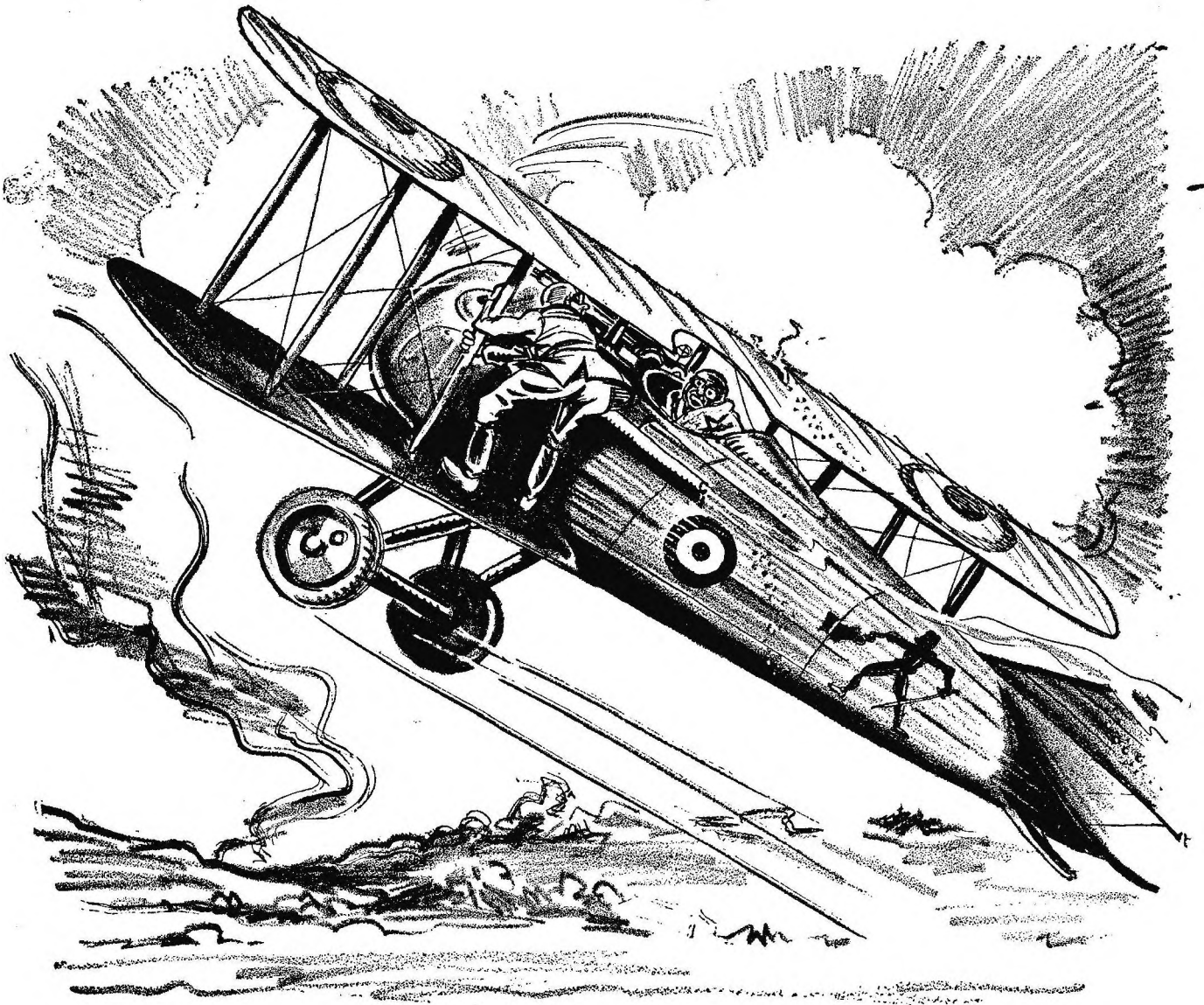

"You can jump now," Phineas chuckled. "We're only three thousand feet up. Haw-w-w!"

of his neck, but he was too dazed to brush it off.

"Somebody—blew up—the joint!" yipped Sergeant Casey, staggering toward the Old Man, his face as black as the inside of a cow. "I bet it was Phin—Lootenant Pinkham. He pl—planted that Heinie sausage where we'd—it's assault—intent to kill—!"

"Why you—you liar!" Phineas howled indignantly. "That is one thing I didn't do. B—But—er—why didn't I think of it? I—you can't prove it, you thick Mick! It was the Von. I bet he thought I'd get it—or us officers would."

And so there was a broad smile on the face of the *Rittmeister* von Bull when he looked at his wrist watch back at the Pfalz hangout.

"Ach," he gutteraled, "*das ist gut!* Twelf by *der* clock already yedt *und der* time *ist*. Maybe *ein* liddle bit lader *und der* Knackwurst it goes bang, *ja!* Ho ho, *der* yoker I am!"

So much for Number Two on the list of skullduggerians. Number Three was sitting, not pretty, in an Allied staff car which came rumbling onto the drome

of the Ninth while Major Garrity's groundhogs cleaned up in the wake of the *Rittmeister's* playful visit. He was a certain individual whom Phineas Pinkham had met on one or two previous occasions. A fly in the Pinkham ointment if there ever was one! The irrepressible jokesmith of the Ninth almost threw a fit when the visitor's unlovely Hibernian visage screwed itself up into a grimace of greeting.

"M-Monk Flanagan!" gulped the Boonetown miracle man. "Oh, you—I thought you was busted for good! You—"

"How dare you insult *Major* Flanagan?" the new arrival retorted loftily, brushing past the lowly Lieutenant Pinkham as he headed for the farmhouse.

"M-Major Flanagan?" stuttered Phineas, hard on his tail. "Why you was only a dough after I got through with ya the last time. Y-you hunk of—"

"Major Garrity," Monk cracked, "is that the way you teach respect for superiors? I am in the Intelligence Corps now. It is a caution how far you can git in this man's *guerre* if you pull the right ropes. Ha! ha! Who'd

ever think I was once an actor, huh? Flanagan and Finnegan, Orpheus Circuit. Ha!"

"There is one rope I would like to pull on your neck," Phineas yipped, "with a hangman's knot in it. Major or no Major, you are still the same fresh mug to me!"

"Look here, Pinkham," Garrity sputtered uncertainly, "you er—keep a civil tongue in your head. Y-You—"

"W-Why Pinkham," Monk Flanagan grinned, "What is that you have inside your shirt? Why I do believe it is—yes it is!"

The Major of the Ninth looked and his eyes revved in their sockets. "Why that's my wallet—you took it out of— Pinkham, you crook!"

"It's a frameup!" protested Phineas. "He lifted that an'—oh, you big wise aleck!" He swung on the Old Man. "Don't fergit who he is. He was vaudeville guy once. A sleight of hand bum. Let me get a punch at that f-fathead. That's the trouble with Congressmen. Even to git votes they make a silk shirt out of a pig's blanket like Flan—"

"I will have you busted for insultin' an officer," Monk Flanagan hollered at him. "Major, put him under arrest or I will report you to Ch—why, it is unthinkable such lack of discipline. I will bust you, too, if you don't arrest this slob!" Suddenly the visiting Major ducked. Phineas had pressed a little button fastened to his lapel. Squish! An evil smelling black fluid spattered the countenance of Major Rufus Garrity. The Old Man set himself like an offensive fullback and lunged at Phineas. The pilot from Boonetown, Iowa, sidestepped and the C.O. charged out through the door without opening it. Fifteen minutes later Lieutenant Pinkham was grounded worse than an angle worm.

"Now we'll get down to my business here," Flanagan said, his whole big frame one huge gloat over events of the first half hour after his arrival at the Ninth. "Now that I've gotten hunk with a certain mug on these

premises. Well, Major, I want the coöperation of the Air Force in getting to the source of the leak on this side of the lines. Those raids of the Krauts were timed pretty close, Garrity. Might need a Spad or two at short notice. Want your coöperation."

The Old Man rubbed a bump as big as an eggplant on his dome and glared at Flanagan. "You'll get it, Major. Plenty!"

"I—I er—don't like the way you said that, Garrity," the Intelligence officer said. "I—er—maybe I was mistaken. Ha! ha! You meant that I could count on you, eh? We'll find those Heinie spies if it takes us—"

A voice contributed an unsought remark through the window. "You frog-faced bum, you could not find a baboon in Africa. Haw-w-w!"

Monk Flanagan ground the enamel from his teeth and swore. "He can't talk like that to me, the freckled mongoose!"

"You forgot to tell him so, I guess," Major Garrity shot back. "Well, Flanagan, you sure came up in the world. No end to what a body can do. Think I'll run for Mayor of Chicago when I go home. Any time you want a Spad, let me know. Still fly them, I suppose?"

"There ain't a bum here who can fly as good," Monk bragged.

"Nuts!" came through the window.

Flanagan made a dash for it but suddenly whirled in his tracks. Phineas Pinkham was standing in the doorway.

"Haw-w-w-w! Somebody is insultin' ya, Major! Any errands you want done, Mr. Garrity, sir?"

"Get out!" roared the C. O., verging on a stroke. "I'll just count three and—"

"Don't flatter yourself," Phineas grinned and disappeared.

"I'll kill that guy yet," stormed the Major.

"Shake," said Monk Flanagan.

"Nuts to you!" ground out Garrity. "If you're through here, Major—"

"Yeah," said Flanagan, "got to go over an' pick up two more Intelligence officers near Thieblemont. They've been watchin' a certain Frog out there. Over the river, Garrity!"

"If you fall in, just come up twice, will ya Flanagan?" the Old Man ripped out. "Intelligence Corps! Ugh."

"Well, this has been a day!" enthused Major Monk Flanagan as he paused and stretched himself outside the door of the farmhouse. "Got Pinkham busted! What more could a guy ask for?" Just then he spotted Bump Gillis walking across the tarmac. Bump was carrying a bottle and Flanagan hurried toward him.

"Gimme that grog!" Major Flanagan barked. "Need it for medicine. Doctor's orders! Hah, no back talk! Here's two francs!"

"B-But," stuttered Bump in protest, "I don't want to sell it. I—"

Monk grabbed the bottle of cognac and strode away, laughing uproariously at the sensation of being a Major who took what he wanted on the Ninth's drome.

AT that moment Phineas Pinkham was riding furiously along the road to Bar-Le-Duc on his bicycle. A hundred yards behind galloped Rollo the faithful. The pooch's tongue was hanging out and dragging on the ground by the time it caught up with its lord and master in front of the house where the Yank's big moment, Babette, abided.

"Go home!" Phineas yipped.

"Woof-wuff!" countered Rollo, sitting on the step.

(Continued on page 78)



Rollo let out a howl and zoomed over the fence.



WISECRACK-UPS



Taxi in on this runway and pick up a plane load of laughs! In this department, we present a collection of jokes, cartoons, and humorous verse. For all original contributions which we can use here, FLYING ACES will pay \$1. Contributions will not be returned—except art work with stamped return envelope.



*Instructor: H-hey, what's the idea?
Student: You told me to make a pancake landing—those are the flips.*

R. P. M.

Salesman: Why do you insist on buying your propellers from companies doing a large business?

Annoyed manager: Well, you see the turn-over's greater.

AH, THE FUTILITY OF IT!

Preacher (alighting at Wake Island from "China Clipper"): Alas, how fleeting are all things mortal!

Pilot: Why, what do you mean?

Preacher: Well, it's here today—and Guam tomorrow.

WHEN Dumb Dora heard that her boy friend had been transferred to a flying squadron aboard one of the aircraft carriers, she immediately sent him a pair of hand-cuffs—for she knew that his airplane would have to be fitted up with arresting gear.

PLAUSIBLE

Visitor: Why do they call those glassed-in turrets on that bomber "green houses"?

Wise guy: Because that's where they plant the gunners.

SAD LOSS

Pilot: Hey, there! Where's that pile of dirt you just swept up?

Grease monkey: Out on the rubbish heap. Why?

Pilot: Well, I can't find my Flying Flea.

DIDN'T USE THE RUNWAY

Cadet: Did you see that pilot who just came in? He landed his plane without rolling.

Instructor: He's got an Autogiro, I suppose.

Cadet: No, he crashed head-on into the Administration Building.

YOU TELL 'EM, PHINEAS!

Phineas (in a great huff): So that's the way Garrity feels about it! Well, just for that, I'll quit flying!

Bump: What's the matter? Did he call you some

names?

Phineas: Naw, he grounded me.

TOO LATE!

SUDDENLY, the motors of that great night-flying transport coughed, stopped jerkily. The plane nosed down. Then something seemed to hit the huge ship, and there were queer rumblings.

Frantically, a passenger stumbled out of his berth. "My heavens!" he screamed to the stewardess, "What's happened? This is awful! Can't something be done?"

But the stewardess only shook her head sadly. "I'm afraid," she told him, "we've done all we can. You'll have to look after yourself from now on. You see, we've just landed."

GOOD IDEA

Dumb: Say, what are you drilling holes in that OX5 engine for?

Dumber: To make it air cooled in case the water evaporates.

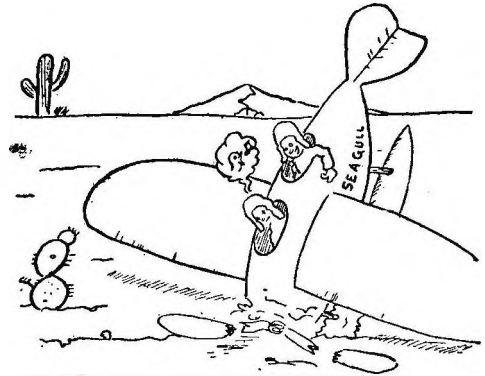

"You win, Johnny. I guess it WAS a mirage!"

O-O-O-F!

Phineas (walking into office of Boone-town Airways): Hello.

Ticket agent: What can I do for you?
Phineas: Has your line got first class pilots?

Ticket agent: Yes, it certainly has.
Phineas: Are your planes safe and are they inspected after each trip?

Ticket agent: Why, yes. And now where do you intend to go?

Phineas: Nowhere. I just came in to get out of the rain.

OUCH!

Ace: My new plane has all the trimmings—flaps, supercharger, pants, and a Dizzy Dean propeller.

Grace: Yes, but what's a Dizzy Dean propeller?

Ace: Controllable pitch.

TAKING NO CHANCES

A SMALL boy was walking past an Army Air Camp, leading a mule by a rope which he held very tightly in his hand. Noticing him, one of the pilots decided to have some fun.

"What are you holding your brother so tightly for, sonny?" he said.

"So he won't join the Air Corps," was the reply.

'ROUND AND 'ROUND

1st Stogie: You say Bill is in the hospital?

2nd Stogie: Y e a h, he took his plane up and tried to do "The Music Goes 'Round and 'Round"—but he couldn't find the place to come out.

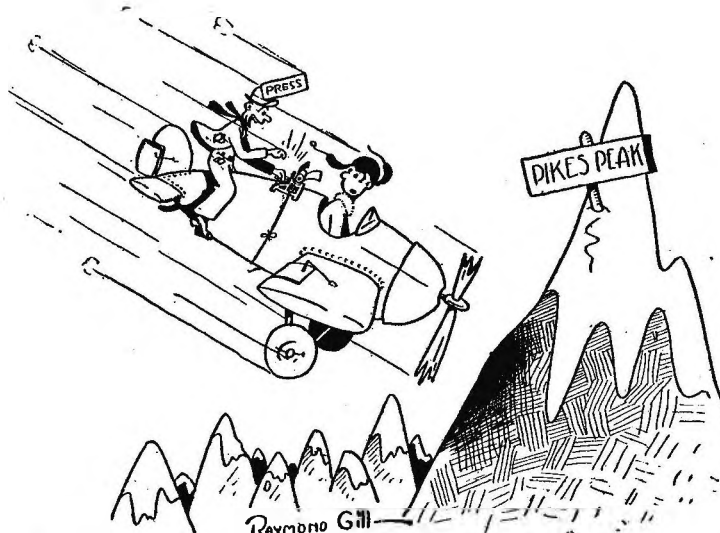

"PLANE CRASHES INTO PIKE'S PEAK!" Boy, what a story this will make!"

Tactics and Strategy of Modern Sky Fighting

By David Martin

Author of "Talons of the American Eagle," "Russia—The Air Power Enigma," etc.

AIR-FIGHTING today is fast becoming a fully developed science—a striking science of high speed warfare embodying elaborate, carefully-thought-out methods whereby fighting pilots may surprise their foe, hurtle in intricate maneuvers, spar for openings, and either attack or defend simply at the flip of their leader's wing. Indeed, the whole sky-fighting scheme gets more and more complex as our airmen progress in skill and as their mounts are improved by the aircraft designers.

In many respects, air-battle tactics have been advanced far beyond the fundamental strategies and tactics which the flyers of the Great War introduced to the World. And there are several reasons for this improvement. But basically, all modern maneuvers are the same as those employed on the Western Front during

How far has the science of battle maneuvers progressed since the days of the World War? Have high speed and mass formations sounded the knell of the individual ace? You'll find the answers to these dramatic questions in the accompanying article, which lucidly describes the fighting methods of military airmen today.

the last two years of the Big Scrap.

And now, let's consider the improvements. What have we got today that they didn't have in the days of Rickenbacker, Bishop, Fonck, Richthofen, *et al.*? Well, we've got fighting machines with surprisingly greater speeds, bombers that are veritable flying fortresses, motor cannons, a complex but effective system of radio sig-

nalling. Best of all, our pilots have had years in which to train for their work, and what is even more important, the ground strategy has improved. By this, we mean that the officials on the ground who now are responsible for giving orders are real flying men who understand air combat conditions and who can judge the strength of the enemy and his future moves more efficiently than the men who held such posts in the heat and flurry of the Great War.

The original air services—those which went into action in 1914-15-16—were commanded by ex-infantry officers who believed they understood what was needed in air tactics. These kiwis were put in command because flying men were then considered useful only for patrols seeking information. They were looked upon only as "eyes" of the Army—not as a means of offense.

Today, our staff officials are men who have been "through it" and understand all flying conditions. They are able to handle their groups accordingly. Thus, modern air strategy and tactics begin on the ground. To get this even clearer, let us define the two words *strategy* and *tactics*.

Strategy refers to the preliminary leading of a patrol in such a way as to assure that the enemy will be engaged under the most favorable conditions. Strategy begins when the leader first spots his enemy. Tactics, on the other hand, are the actions or maneuvers brought into play when the two patrols actually enter combat.

We could not begin to cover these two fields completely in this article, for there are innumerable angles to air strategy and tactics. Simply to cover the work of Naval planes

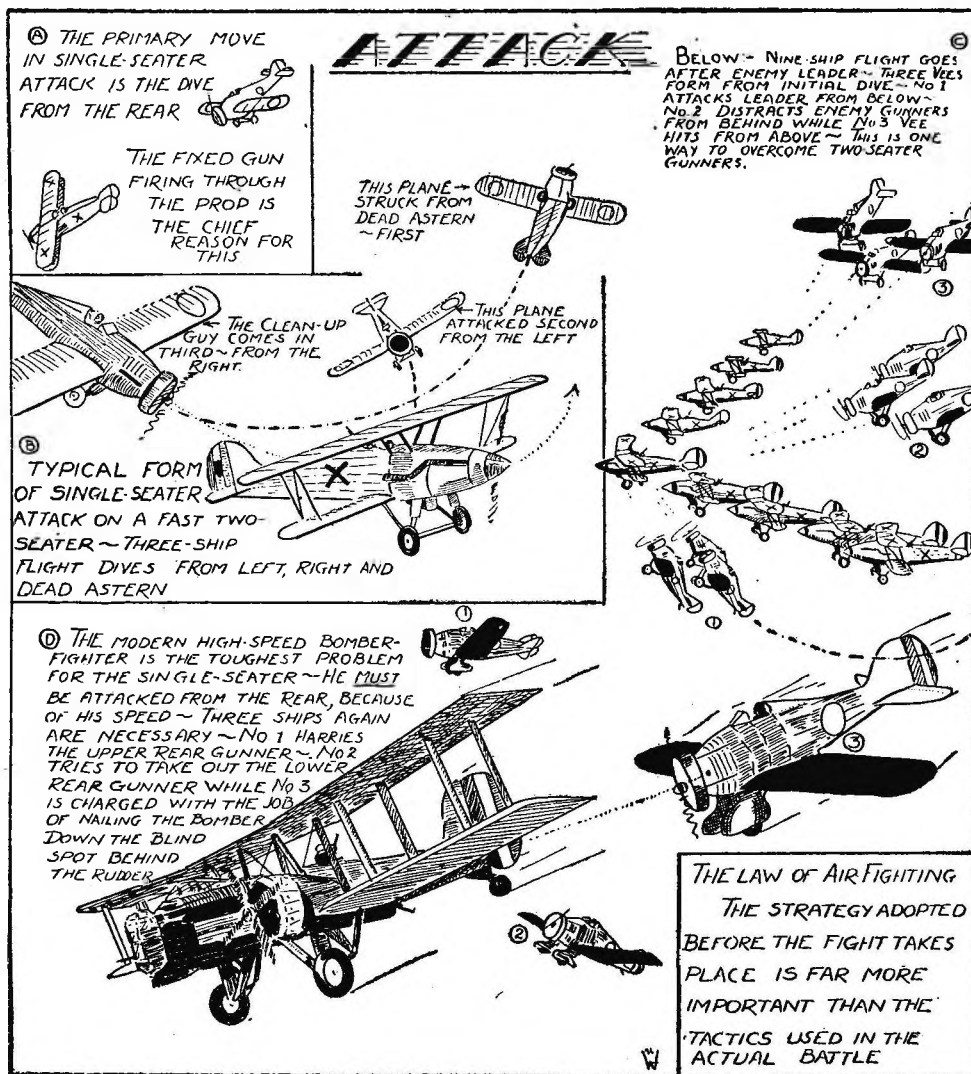

in conjunction with the surface fleets, for instance, would require the space of a full volume. But we will attempt here, to explain the primary moves of the various types of military craft in offensive and defensive action, hoping that this will give the reader some idea of the complex training required to produce a first-class fighting airman.

TO begin with, we will show the routine work of single-seater formations in action on offense, and we will consider the reasons for the various formations and maneuvers adopted.

All tactics in single-seater action are based on the fact that the guns in these machines are usually fixed to fire along the flight line of the ship in question. Back in the old war days, the S.E.5, the Nieuport scout, and a ship-board version of the Sopwith Camel had a semi-flexible Lewis gun mounted on the top plane. This gun could be fired at an angle from below upon an enemy target flying above—and it often was; but today such a gun is out of the question, for the pilot of the modern single-place job has all he can take care of simply in flying his mount which has a top speed of anything up to 250 miles an hour. It would be virtually impossible for him to handle a movable gun while piloting his craft in the neighborhood of 200 miles an hour.

So, for this reason the first move in single-seater action is to dive from the rear on the enemy target, and this goes for attack on all types. In fighting hostile single-seaters, the battle is usually won before the elements actually come to grips, for the strategy adopted a few minutes before they actually "open up" with action constitutes the greater part of the game.

The altitude selected—the height most suitable for the machine used—is the first consideration. The position of attack with relationship to the sun and prevailing wind may come next. The final consideration is the selection of the actual instant of attack.

A point that may be confusing to the average reader is the present-day idea of what comprises a flight. During the war and up until recently a flight usually consisted of six machines, but during the past few years, the term must be considered more elastic. Today, a flight may be three machines or a multiple thereof. In short, any number of three-machine flights may combine into a formation.

The squadron idea is also somewhat mystifying now in relationship to the old standards. It appears at present that the number of planes in a squadron depends upon the type of machine involved. For instance, in the United States a pursuit squadron is composed of eighteen planes—or two nine-ship formations of three three-ship elements—and the *pursuit group* is composed of fifty-four planes, while in a *bombing group*, thirty-nine is the accepted number. Like the pursuit groups, the observation and attack groups are also composed of fifty-four planes.

Aboard, the composition of the various flights, squadrons, and wings follow no set rule, and Naval outfits seem to be arranged with consideration for their bases. What may be a flight with a cruiser is something entire-

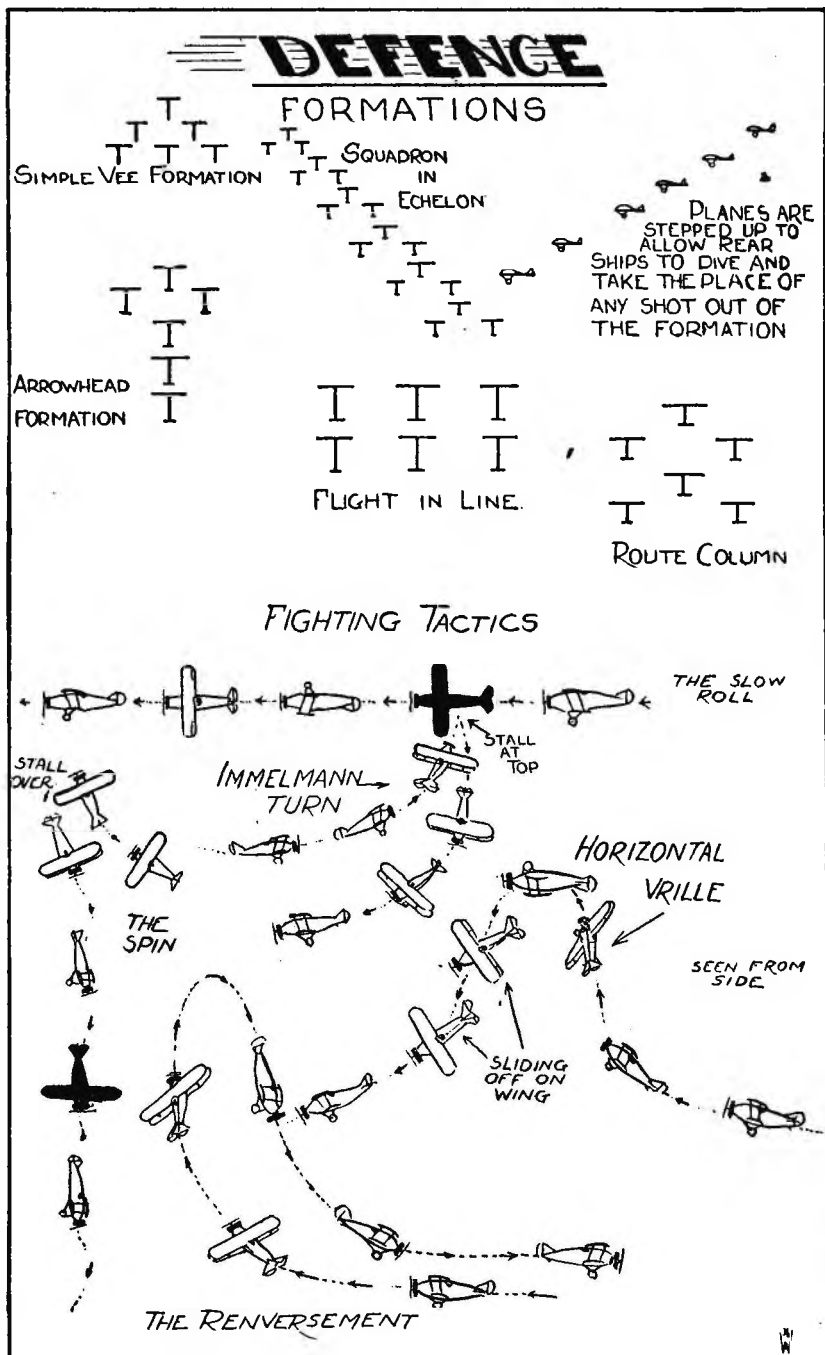

ly different aboard one of the aircraft carriers.

But, to get back to the maneuvers and tactics employed by single-seaters, we also must consider the method of a single-seater versus a two-seat fighter or attack plane. Here we find the main reason for the three-ship element; for in attacking a two-seater today, the single-seaters are out-gunned and they must overcome this disadvantage by adopting an effective retaliatory method of attack.

Note Figure "B" in our accompanying diagram of attack maneuvers. Here we show how the single-seaters may defeat the gunner. They dive together in an ordinary Vee and one ship—the leader—slams at the gunner and the tail from dead astern. Almost at the same time the other two planes swing off and cut in, one from the right and one from the left. It is impossible for the gunner to take them all on, and since they are attacking from the rear, the pilot's front guns are out of action. Thus, if the gunner stops one plane, or drives it off, the second or third are in position to pick him off. It's a three-to-one proposition.

(Continued on page 90)

Sky Gun Snare

Mastery of the skies! That was what the Grice Flexthud gun would mean to the World Power fortunate enough to possess it! But on the very eve of its Government test, sinister men plunged down from the black heavens and snatched away both that deadly weapon and its inventor. And the men who sought to solve that mystery failed—because they did not know that the thieves were not kidnapers, and the kidnapers were not thieves!

• • •

THE world had fallen about John Grice! His wonder gun, the aircraft weapon that would put his country in first position as a world air power, had been cruelly snatched from his hands—just when success, official recognition, and a fortune were less than forty-eight hours away!

John Grice sat stupefied. His little factory was more than three miles from a State Police depot and he had no telephone. The despoilers had come by air—and left in the same way.

The blow had been struck with a cruel, swift silence that had left John Grice a hopeless wreck. Gone! The fruits of his lifetime effort!

The Grice Flexthud gun was the marvel of the age—a wicked weapon capable of hurling 200 one-pound shells a minute with amazing accuracy. He had been too late in sensing that the sooner he got it out of his little workshop and safely behind the steel doors of the Ordnance Department, the better off everyone concerned would be.

"Eighteen years," he mumbled, fingering a scrap of metal on his desk. "Eighteen years—and this is my reward." He turned in his broken chair, stared across the small room. All he had left was rolled up in a long tube hidden away there in the wall.

John Grice brushed a tear from his eye as he pondered on the respective merits of the bullet, the noose, or poison. He knew he could never go through it all again. A bullet would be a quick and easy way out. The noose might not do a clean job, and the vial—Well, John Grice never could stand strong drinks.

Wearily he reached inside a crude box-drawer fitted under his bench. He pulled out a large caliber pistol.

But abruptly a strange wail caught his ear. Then it ceased and the wind seem to rise into a strange whistle. It was something like the high winds of Buzzard's Bay whistling through the tall pines. John Grice hesitated a minute, fingered the heavy chamber of his gun. Then there came two coughing thuds and he went to the window and stared out.

Something sleek and black came up out of the nothingness of water and sky and rolled toward the little building. John Grice put the gun back on the bench, steadied himself. He was at a loss to understand it all.

He turned again and reached for his gun—but he turned around too late.

Two masked men in black coveralls, black parachute harnesses, had stepped quietly into the room. They both covered John Grice with massive automatics. And they

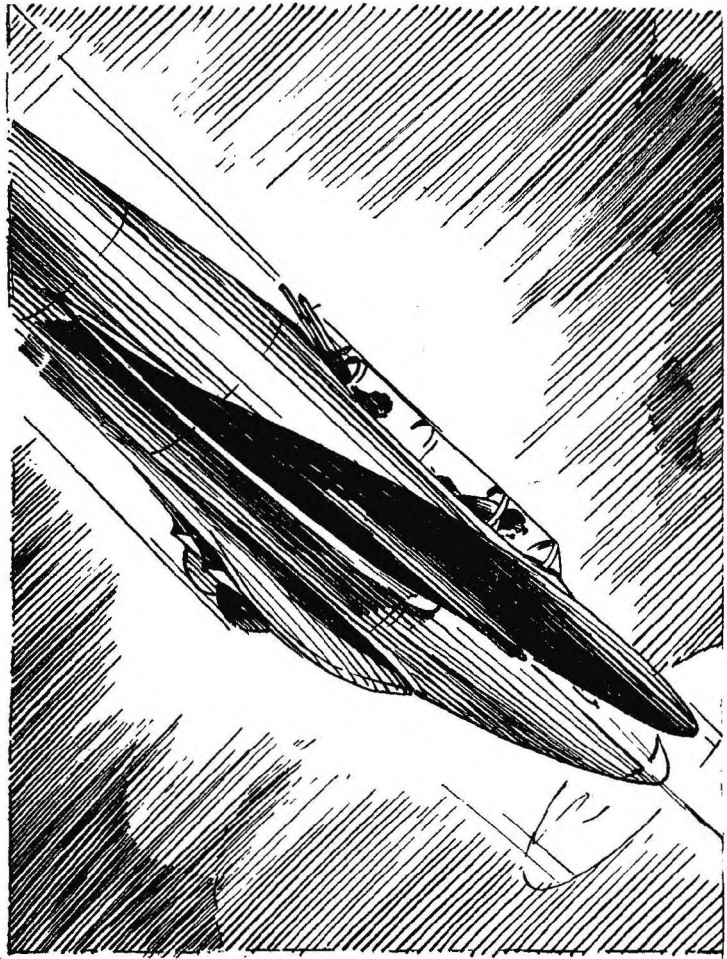

Illustrated by Alden McWilliams

Along the fuselage of that hurtling Dornier, Keen's withering fire stitched a pattern of death. The pilot jerked, slumped in his pit. And at that moment the huge projectile slithered from its carriage and plunged downward.

made John Grice realize that no matter what had happened less than an hour before, he most certainly wanted to *live* now.

"Where's the gun?" demanded the taller of the two men.

"The gun? . . . Here it is," Grice replied, handing over his old pistol.

The tall man in black looked at it carefully, broke it with an effort and let the cartridges fall to the floor. He stared across at John Grice puzzled.

"What were you going to do with that?" he snapped, moving forward.

"You're late . . . half an hour late. Someone came and took it," the old inventor muttered.

"You mean—your new gun? Someone took it? When?"

"I just told you. Less than half an hour ago."

"Who was it?"

"Renklund—Thaddeus Renklund. The man who owns this building."

"Renklund . . . Renklund," the man in black muttered. "How did he know what you were working on here?"

"He was pushing me for the rent. I had no more money left and he wanted to put me out, so I told him what I

ANOTHER GRIPPING "KERRY KEEN" MYSTERY NOVELET

By Arch Whitehouse

Author of "Flight Deck Fury," "Trans-Atlantic Intrigue," etc.

was doing. But I don't know why I should talk to you," the old man suddenly blazed.

"Then you showed him the gun and he agreed to let you stay on, until you sold it . . . to someone, eh?" the man in black snapped in a strange metallic voice.

"He came in a flying boat of some sort and sneaked in with two other men. They took the gun and said that he intended to hold it until I paid up. But they used a gun on me."

The man in black went across to the side wall. He had noticed Grice's eyes moving over that way. There was an aged calendar hanging there. He drew the end up, looked underneath. A long narrow door was fitted into the wall. He opened it, took out a heavy cardboard mailing tube that was fitted with a screw cap top.

"Don't!" screamed John Grice. "Don't take them. That's all I've got left!"

"Do you want to sit here and wait for them to come back and finish you off properly?" the man in black asked. "Do you think you are going to hold onto these blueprints while they have the gun itself? What I can't understand is why they even left without them."

John Grice did not answer. He seemed to be trying to solve the strange intonation of that voice. There was something familiar about it, but it seemed to be coming from a metallic transmitter.

"You are not to be trusted in a matter as important as this, Grice," the man in black went on. "Take care of him, Pulski!"

John Grice had to submit to a quick search of his pockets. Then his hands were tied behind his back and he was carefully blindfolded. Then the men hurried him out of the door and across to where a trim black amphibian snuggled in the shadows.

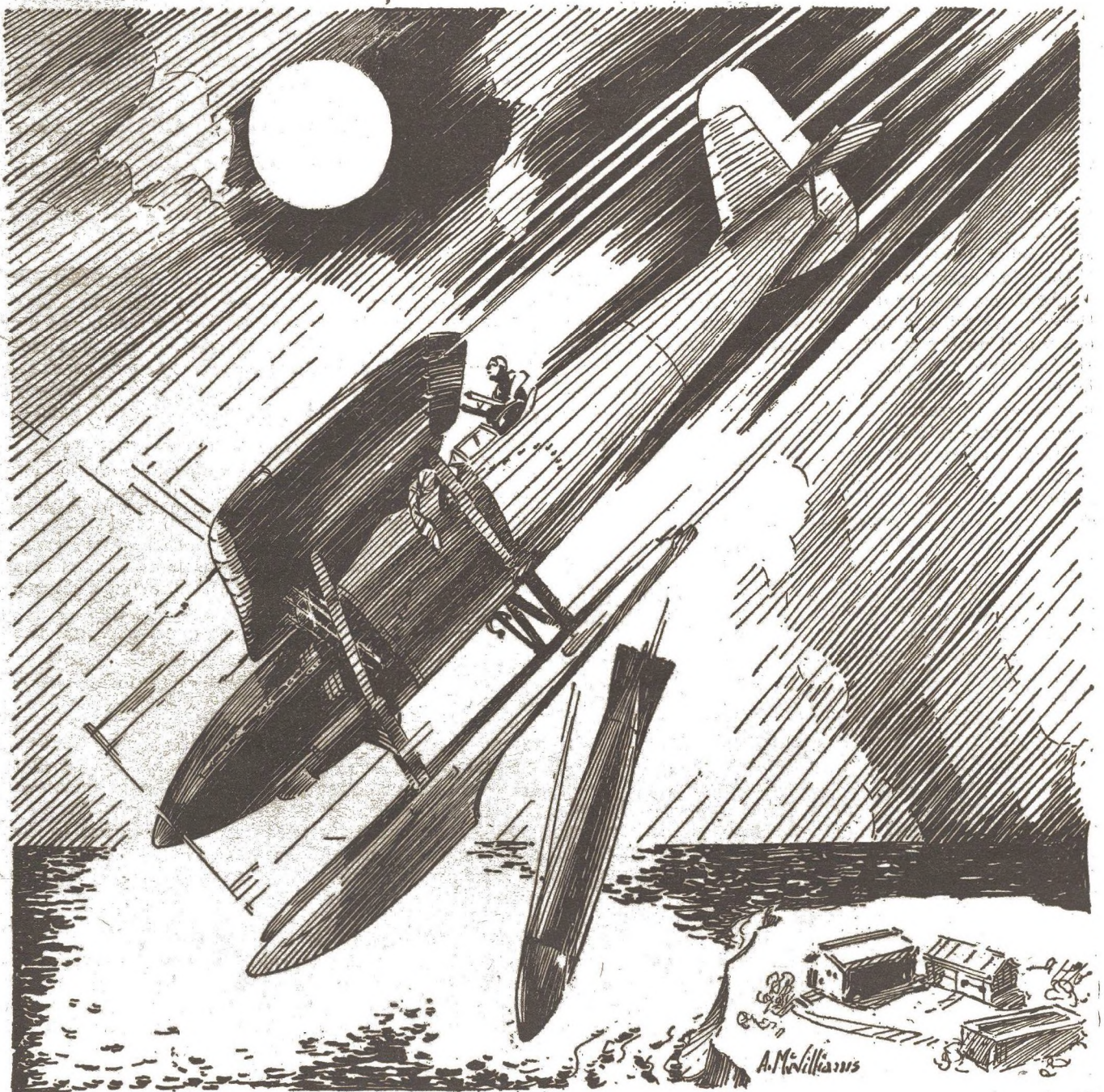

In three minutes they were winging their way across the Stratford meadows and toward Long Island Sound. The ship's great 1,000 h.p. Avia engine, muffled through the Skodas, was singing a low song of power.

But no sooner had they reached 4,000 and turned north-east toward the flashing beam of Montauk Light, than the inevitable happened!

A green and white, dazzle-painted flying boat pounded down on them from above and poured a stream of fire into the black amphibian.

THE man in the back seat of the black plane was badly hampered in returning the fire, for he was also acting as a guard over the blindfolded John Grice. But he turned as soon as he realized what had happened and broke out a black machine gun. The big flying boat—a Sikorsky S-43—was curling around smartly to give another gunner a chance at them from the other side.

"What's going on?" screamed John Grice.

"Sit still and hang on," the gunner in the black amphibian growled. "Your friends are back."

"Brat-a-tat-tat-tat—" the gun drowned out the rest of his statement.

For several minutes the battle went on, with the gunners from the flying boat giving a wicked account of themselves. They flailed away with plenty of everything. And now, just as the black amphibian gained considerable height over the flying boat, an emergency hatch was opened in the S-43 from which two guns flamed and spat. The black amphibian rang with the battering at her dural frame, and her masked pilot whipped her clear with a growl that was something between an oath and a cry of admiration.

"No use wasting any more time on these lads," he muttered. "Here goes!"

He set the mechanism for the heavy caliber Darn guns mounted in the wing and nosed down. With everything clear, he let fly, and the black amphibian danced under the thunderous vibration. He held her steady as they smacked into the Sikorsky's curtain of fire.

Then the ship below them jerked. A gusher of smoke belched out, swept back over her massive tail to be sliced into two streamers by the fin. Another long burst, a pull on the rudder, and the black pilot swept across the S-43's big wing. He saw the boat's starboard engine spin out of the bearers. Its three-bladed prop gashed out a massive chunk of the control cabin and the big Sikorsky started to spin.

The black amphibian whipped up with a scream, curled over again, and came down with a roar.

The *coup de grace!*

A long burst smashed into the nose of the boat, slashed the cabin to shreds. The Sikorsky shook, rolled over on her back. Then down she went, the remaining engine still screaming and jerking the port wing around in wild struggling gestures.

"That's that," the black pilot announced, closing in to watch the finish.

They circled the tumbling mass, watched the great beam of Montauk swing around gently and light the falling wreckage. The black pilot had to fly carefully to keep clear of the tumbling debris. The sky glinted strangely with it.

Then there was a thunderous slap as riddled fuselage of the boat hit somewhere below.

Like a shot, the black pilot nosed down, shoved in the Skodas so that the Avia simply purred. He cut the prop, then landed the amphib to windward of the wreck. His gunner got out, boarded the half-sunken flying boat when they had drifted alongside, and stared inside the watery hulk, which he lighted with his pocket flashlight.

In a minute he came back, tucking a small leather case into his pocket.

"You don't need to bother about anyone who was in there, Ginsberg," he said. "Besides, it ain't nice to look at. We'd better beat it!"

They closed the cockpit cowling and raced away again.

"Those were your 'pals,' Mr. Grice," the pilot barked over his shoulder. "We pulled you out just in time before they came back for you."

"Are they all dead?"

"So Pulski says."

"But what about my gun?"

"You needn't worry about that. They didn't bring that along this time. But if they had, it couldn't be safer, for you can be sure divers will go down for that boat. And when they do, they'll be sure to find anything of value—so there you are."

There seemed to be nothing else to say. But John Grice wondered why he had been bound and blindfolded by these two men who did not act as though they were his captors. But so many strange things had happened in the past few hours! He was unable to think straight any more.

The rest of the flight ended quickly enough. But the blindfolded John Grice could not know that they landed off East Hampton, ran up out of the water to a concrete ramp, then eased across a neat lawn to the face of an innocent looking rock garden.

Nor could John Grice know that the face of the rock garden opened outward and that the black amphibian folded its wings and ran inside. He knew nothing of his surroundings until he was finally unbound and the blindfold removed. Then he discovered that he was comfortably settled in a large room, quietly but expensively furnished with everything he might desire at hand—except his freedom.

The pilot of the amphibian explained the situation to the old inventor in no uncertain words:

"You will remain here, Mr. Grice, until we see fit to allow you to leave. If you make an attempt to escape, I shall be forced to adopt harsh methods. Behave yourself and rely on me, and there will be a slight chance that we can get your gun back in time to meet the Ordnance officials at Ramshead Island."

"What do *you* know about my gun . . . and the Ordnance officials?" John Grice demanded.

"I haven't time to argue with you now, sir," the black pilot replied. "There is too much work to be done. In the meantime, there is your bed. You will find a decanter of choice sherry over there. I bid you good night. And I might add that this room is carefully wired, so that any move you make toward the door or wall panels will be carefully registered. I think you understand."

John Grice was too tired to argue. He turned to the bed, grateful for a comfortable mattress. He was asleep long before Kerry Keen's Dusenbergs purred out of the driveway and hit the road for New York City.

THE telephone bell jangled in Kerry Keen's bedroom at 10 o'clock next morning. The noise of the 55th Street traffic below had failed to awaken him, but that telephone bell only had to tinkle once to make him alert. As a matter of fact, he had been expecting it.

"Hel-l-l-o!" he called into the receiver.

"That you, Keen?"

(Continued on page 71)



Repulse of a Rhineland Camera Raid

DRAMATIC STORY BEHIND MR. MOREY'S COVER PAINTING



IT would be a startling twist of fate if a mere camera and a roll of film hurled Europe into another international carnage—yet this might possibly happen!

It took the assassination of a comparatively unknown Austrian Archduke to plunge Europe into a war back in 1914, but a camera may do it in 1936. Under ordinary circumstances, a camera is an interesting device that may provide a healthy hobby. These innocent-looking devices, however, have sent many a man to his death—that is, they've provided the evidence that resulted in his death sentence.

In other words, the camera may be a harmless piece of vacation equipment—or it may become the most deadly weapon in the world. Like a gun, it all depends on what you aim it at—and when.

Our cover this month, Mr. Morey, our new cover artist, depicts with stark realism an incident of fiction over the frontier—the type of incident which is not uncommon on the Franco-German border now that the German government has decided to come out into the open and admit it has an air service.

Several recent news items have told of German military machines being seen over the French border—and always in the forbidden area between Longoyon and Lauterborg. Every week a new protest is made by the French government and at least once a month, a German military plane comes to grief and has a "forced landing" in Swiss territory!

The answer is as plain as the nose on your face, and our artist has depicted just why so many German military planes seem to have forced landings in Switzerland.

Believe it or not, there is a fight going on at this very minute in the air over the Franco-German border. We only hear of the German planes that landed in Switzerland with "engine trouble." There are no doubt other German planes—and maybe French planes, too—that landed otherwise.

The French recently announced to the German government that they were putting up regular formations of defensive planes to patrol the border. These planes are equipped with special cameras—cameras to photograph the German planes that fly too near the border—and also wireless equipment that will enable them to warn certain agencies below in case anything serious happens. The French did not consider it necessary to announce also that these same planes carry motor cannons.

The layman naturally asks: "But what can the Germans gain with long-range photography? During the war they were all over that sector and they ought to know every inch of it."

They did until 1925 when the French started work on their amazing Maginot Line—the unbelievable chain of fortified and armored casemates that stretch from Longoyon to Lauterborg. This underground system of fortifications, running through the frontier area in front of the Briey industrial area and Metz, is the one stumbling block to Germany's hopes of raiding France again. She knows that she can never go through Belgium again. That was her great mistake of 1914. It brought in the whole British Empire against her and eventually the United States, too, for it was the invasion of Belgium that played the greatest part in establishing America's sympathies with the Allies.

If Germany hopes to invade France she must first

solve the mystery of this amazing Maginot Line.

So far, all that can be seen from the air of the Maginot Line are the bulbous mushroom-like casemates that emerge out of the vast maze of galleries, magazines, armored posts, and power stations hidden away hundreds of feet below the ground. Germany wants to solve the secret of the Maginot layout and she hopes to do it by special aerial photography which employs the use of infra-red plates that will bring out unseen contours and may detect where the mysterious galleries run.

It will take months, perhaps years, to do this, and the airmen selected for the work are probably the finest Germany could find. These men are on active service today and under actual war conditions far more dangerous than those faced by the airmen of Mussolini in Ethiopia.

CAREFUL camera work may lead to the undoing of the Maginot line. So far, the Germans probably have the full detail of the partially screened casemates which appear above ground in wooded areas and which no doubt carry the armament and guns which will be used in defense of the area.

But they cannot photograph the hidden galleries below where special ammunition magazines will be found and air lock devices for the all-important protection against poison gas. Within there are sleeping and living quarters for thousands of men, and each section is completely independent of the others although they are set in such a manner as to be able to cover each other with cross fire in case of an attack.

The men who will man the Maginot casemates in the event of an attack are highly skilled reserves who live in the nearby villages and who can take their posts within a very few minutes.

This, then—the Maginot Line—is the reason for all of Germany's camera flights over the French frontier. Whether they will succeed in solving the concrete and steel mystery depends mainly on the cameras. If they can fathom the positions of the various strong points and work out a method of attack with gas or high explosive, war may flare out again instantly.

Our artist has depicted a scene that may be taking place at this very minute over the Maginot Line. It shows a German Messerschmitt M-29 low-wing two-seater which has been converted into a special photography job. She carries an Argus engine.

The Messerschmitt M-29 boasts a maximum speed of 162 and is particularly suitable for this special camera work, for it can be flown at low speeds when so desired, thus giving the observer a steady platform for his delicate work.

Details of this machine were divulged in our March issue. It lands at 37 m.p.h. with a full load and with almost empty tanks it can be brought in at 34, which gives an indication of her stalling speed and how little velocity she requires to maintain safe headway.

The French pursuit is the well-known Dewoitine D-500, a popular ship with our model fans. It is a standard job with the French Air Service. It is powered with the 500 h.p. Hispano-Suiza 12Xbrs engine and has a reputed top speed of 231 m.p.h. at 15,000 feet. Two Vickers guns are carried and considerable military equipment, plus oxygen devices, wireless shortwave telephone, a cockpit heating unit, and the like.

Cunning of the Camera Hawk

* * *

A SMASHING TALE OF ALEUTIAN INTRIGUE

By James Perley Hughes

Author of "Gods Must Have Wings," "Brood of the Black Dragon," etc.

SUDDEN tautness gripped the crew that manned the mechanical "ears" the U.S. Navy had installed on far away Seal Island. These gigantic sound detectors had been registering strange purrings for several hours—but now they gave off the undisguised, rhythmic beat of a powerful aircraft motor.

Quickly, the "ear" men swung their control wheels until the direction arrow pointed dead on, but Harvey Mason was more interested in the sound track left by an ink-fed stylus. His brows knitted. Blue eyes, clear as the glacial ice of that far Northern clime, flicked around to stare into Commander Jacobson's sober face.

"Mitsubishi-Jaguar," was all that Mason said.

The commander nodded, his lips tightening almost to knife-blade thinness. The American Navy was establishing an outpost at the tip of the Aleutian Islands. Seaplanes were housed in cleverly concealed bomb-proof shelters beside a tiny bay. The Orient had become a veritable keg of dynamite in 1936, and now, in 1937, the Navy was quietly building the most modern air base American inventive genius could create. It was to be a look-out post to stare down on teeming Asia, seething with unrest and lust for conquest. That rival powers would seek to learn the secrets of Seal Island had been long foreshadowed. That was why Commander Jacobson and his squadron of speedy F7B-10 Scout seaplanes had been detailed to patrol the far-flung Aleutians. And the Scout was just the plane for the work—a pontoon version of the great Boeing F7B ships brought to perfection in '36.

"See," Mason went on, "that seven cylinder beat. The Kawasakis have just been fitted with that type of motor."

Jacobson nodded. He raised his high-power glasses to sweep the sky in the direction in which the sound arrow was pointing, but he could see nothing.

"I expect you'd better have a look around," he said quietly.

"Aye-aye, sir."

Mason's voice was level, but he felt a tingle run through him. Of the post war generation of pilots, he was more the scientist than the warrior. The war birds of France had fought and died in ships that were now regarded as interesting relics. Death crates, flaming coffins flying on the wings of doom. They were only distant ancestors of the sturdy, efficient ships piloted by the Navy's eagles.

A cross wind was blowing as Mason ordered his F7B-10 Scout eased down the ramp and into the water. He wrenched on the inertia starter and the engine roared. A quick warm-up and he swooped up into the air with the grace of a swallow. In another moment, the Scout was climbing rapidly, almost hanging on its prop, as Mason widened the throttle to its limit.

He soared upward at a pace that made his eardrums tingle, then leveled and cut in his motor silencer. Now the plane purred through the

upper air with no more noise than an automobile. Mason snapped on his radio-telephone, called a code number into the transmitter. An answer came giving the position of the Kawasaki. Its engine was still registering its presence, according to word from the ground whisped in mystic letters and numbers.

Mason looked to his guns. A pilot, who had the temerity to fly over the forbidding Aleutians would not be unarmed. These Navy flyers might hear the battle call at any moment. He snapped bullets into the breechlocks of his Brownings, then fitted a shell into the one pounder that fired through the prop hub. He was ready for any emergency.

With the motor silenced, he threw a switch that shot life into the sound detectors built into the tips of his own wings. The arrow of the dial on his instrument board pointed far to the right. He brought the little ship around until the indicator was at zero. Next, he pressed a button that would register the elevation of the invader. Mason's blue eyes thinned when he saw the Kawasaki was more than five thousand feet above him, skimming the ceiling. Only a powerful-engined machine could hold that sub-stratospheric height.

SWITCHING on the supercharger, Mason again dropped the tail and resumed his climbing. He was forced to cut out the silencer for this steep ascent. The muffle took too much of his power. But in spite of the thin air, the little ship mounted swiftly. He looked down to see Seal Island little more than a speck upon the blue field of the North Pacific. Stretching toward the East was a parade of dots marking this chain of rocky isles flung across the sea from the tip of the Seward Peninsula.

Once more Mason cut in his sound detector and muffled his engine. He cruised until the arrow on the instrument board again pointed to zero. A touch on the throttle and the little ship swept forward at racing speed.

Adventure, battle perhaps, lay straight ahead. Mason's heart beat quickened. He had listened to the tales of veterans of the Western Front, and he longed to taste the rich wine of combat. No thought of death or danger plagued him. It was sport—like the speed tests in Los Angeles in which he had taken part as the Navy's representative. That had been real fun, especially that duel with Yomomato, the Oriental speed ace who had won when Mason's own ship developed mechanical trouble in the third lap.

Yomomato had been a sport and expressed his sorrow at the accident. He had been courteous enough to say that Mason would have won, but for a motor mishap.

True, Mason's mechanics had spoken harshly of sabotage and had hinted that the soft spoken Yomomato might have had a hand in it, but the American had gruffly silenced them. Now he was going into an adventure where motor trouble might lead to something more serious than loss of a race.

Out over the turbulent waters of the distant Pacific, where East meets West, Harvey Mason, crack Navy flyer, flew his speedy Scout into the toughest jam of his career. And then to get out of it, he flagrantly disobeyed his commander. But he soon found that one wrong didn't make a right—so he had to make it two.

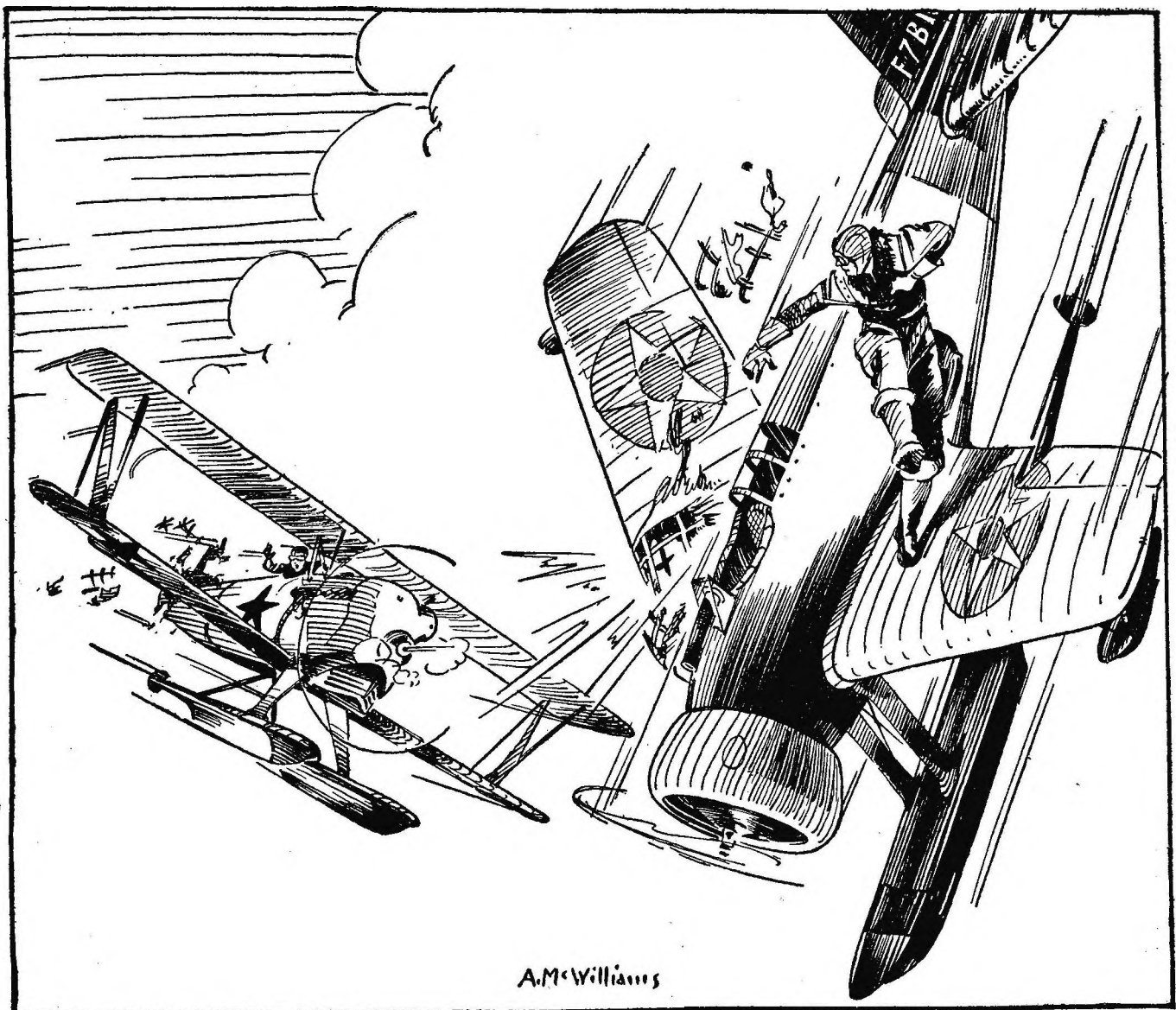

Illustrated by Alden McWilliams

From the prop hub of the disabled, star-marked ship, flame suddenly darted. There came a sickening thud, and Mason's right wing buckled, tore off at the root! Stunned, half-unconscious, Mason hurled himself from his pit.

The little Scout leaped through the air at a speed surpassing three hundreds miles an hour. She was the latest thing in the Navy—a secret-list craft which pilots were forbidden to fly at top speed when within sight of land. Mason gave the motor full gun, hurtled through the sky at dizzy pace.

A speck appeared before him, a speck with wings. He clapped high powered glasses to his eyes and an airplane swam into the field of vision. It was not an American craft. Neither was it the conventional Kawasaki, whose design he had studied before coming to Seal Island. The two ships were approaching each other at racing speed. Mason turned the focussing screw on his binoculars to get a clearer view. His lips tightened. It was a Kawasaki—but an improved, seaplane type capable of great power.

With both machines traveling at five miles a minute, only seconds intervened between first sight and meeting. Harvey Mason had kept his binoculars to his eyes, holding the focus at the alien craft swept toward him. Through the haze of the swiftly spinning prop, he glimpsed the head of the pilot. The man wore no goggles, but crouched below a windshield of shatter proof glass. The American's eyes thinned as his powerful lenses brought the man's face so close that he looked as though he were not more than ten feet away. No doubt as to his identity. Mason had seen that ivory

tinted face too many times not to recognize it.

Yosuki Yomomato, his erstwhile air race rival, was riding a Kawasaki combat plane over the Aleutian Islands! And only one mission could bring him there. Harvey Mason stiffened in his seat, glanced at his guns. Then he cut out his silencer. He would want all the power his bellowing engine could develop.

As his plane leaped forward, he heard a buzzing in his noise insulated earphones. Instead of using the radio phone, the message was being sent in dots and dashes.

Under no circumstances use guns—Jacobson, the wireless instructed.

Mason's hand dropped from the firing trip built into his stick. Jacobson was following orders from Washington to avoid anything that might be regarded as an overt act. It put Harvey Mason into the position of being in the ring with an opponent with instructions to guard himself at all times—but not to strike back.

Another glance at the Kawasaki. It was almost upon him. Something that resembled a hawse pipe slightly protruded from the machine's underbody. Mason recognized the opening for an aerial camera. Yomomato had been photographing Seal Island from a height of six miles or more! The films would be enlarged to motion picture screen proportions, revealing every phase of the outpost's development. Canny, almond eyes would

study them from every angle. When they were done, Seal Island would be an open book, not a well guarded secret.

THE Kawasaki was abreast of him and Mason waved his hand to the crouching pilot. Then he pointed to the lapping waves far below. He was ordering the visitor down. Yomomato turned as his machine swept by. His head bobbed in the conventional little Japanese bow and his white teeth glistened in a mirthless smile, but he made no effort to follow Mason's orders.

The American kicked his right pedal and threw his stick over to make the scout spin on its wing tips. A snap, and again he cut in the supercharger. The little plane leaped ahead like a war horse feeling its master's spur. Nothing made by man could equal the speed of this Navy Scout and Mason quickly closed the distance between the two.

Yomomato did not look around. He was crouching over his instrument board, apparently sending a radio message to his own base. Mason tripped his Brownings to attract the man's attention. Three sharp blasts snapped out and the Japanese spun in his cockpit.

"Get down—submit to search," the American yelled, pantomiming his words.

The Kawasaki's nose dropped into a screaming dive. Mason followed, throttling his motor. Even the sturdy Scout might be torn to pieces by a pull-up when traveling at his present rate.

Down, down, down they hurtled. To the American's eyes it looked as though the green-blue waves of the Pacific were reaching up to clasp them to its destructive bosom. Mason glanced along the line of their descent. Far ahead was a small fishing schooner. It was the type used for pelagic sealing. Barred from the Pribilof Islands, where the United States government has a monopoly in the annual harvest of skins, the Japanese send out schooners to catch the seals at sea.

A flash of understanding shot through Mason. Yomomato had used this supposed sealing schooner as a base. Equipped with collapsible wings, the Kawasaki could easily be stored. He was making for that haven with all the speed his highly powered engine could develop. The schooner was doubtlessly armed, and Mason would plunge into the zone of anti-aircraft guns unless he halted Yomomato's flight. Once more he touched his Brownings to fire a signal blast.

Instead of speeding his flight, the Japanese pulled up into a sharp loop. A roar of fully sauced cylinders and the Kawasaki came down on Mason's tail. Then came a sputter of machine gun fire. Their very sound told the American that twin Vickers guns of Japanese manufacture were firing at him. He glimpsed the cone-shaped tracer bullets that sped by as he kicked off to the right. At the same time, he heard fresh wireless buzzing in his earphones:

Any more firing will lead to court martial—Jacobson.

Another burst from his opponent. Mason dodged out of the streaming line of bullets. He could not fight back, yet must keep the Kawasaki engaged. Although his fleet winged Scout had superior speed and flexibility, the American found himself in constant danger of being riddled.

Yomomato's plan was quickly apparent. First of all he must get safely away. The death of Harvey Mason would only be incidental to his tactics.

The two planes now maneuvered at racing speed, using all the tricks of the stunt pilot in attack and defense. But each rush by the Kawasaki brought it nearer to the

pseudo sealing schooner, far below. Mason, however, used his superior speed to shorten these rushes and he forced the Oriental to dart toward Seal Islands several times in order to avoid a crack-up in mid-air. Mason's lips tightened when he saw Yomomato working with the one pound gun firing through the hub of his propeller. One well-aimed shot from that weapon and the American plane would be put out of action.

"SE—345—speaking—calling ED—1," Mason called into his radio phone. No time to spell out with dots and dashes. Death might come at any moment. The Kawasaki was speeding its maneuvers and drawing closer with each burst of fire.

"Okay, SE—345—ED—1 responding," Commander Jacobson's voice came through the air.

Mason kicked the scout off to the right and spoke hurriedly into the transmitter.

"Kawasaki Type IV—serial 2,348—attacking with Vickers—preparing to use one-pound hub gun. What are your instructions?"

A breathless wait, seconds only in actual time, but age-long at that moment. Then Jacobson's resonant voice made the earphones pulsate.

"Instructions—under no circumstances return fire. Aid taking off in few minutes."

"Okay, ED—1—Instructions received and will be obeyed—SE—345 signs off," Mason's voice was level, although he had heard his doom pronounced!

YOSUKI YOMOMATO had also heard—the American realized it a moment later. He had no doubt but what his enemy had kept his radio switch closed and his set tuned in on the American wave length. He could not help hearing Jacobson's instructions. But he had had no such peaceful orders and he hurled the Kawasaki at his adversary at a speed that quickly brought him within firing range. The Vickers blazed. Then a flame shot from his hub cap. Harvey Mason snatched open his contact switch. His engine stopped its bellow instantly. A gray streak shot ahead of the American plane. Yomomato had aimed at his motor, but Mason's quick action had slowed his speed in time to force a miss.

The Japanese increased the tempo of his attack, striking with a savagery that told of burning rage. Heretofore, he had made no attempt to kill Mason. He had sought to put his plane down where rescue would be an easy matter. Now he sought blood. Relief was coming. The sky would be stippled with American planes. Even if they did not fire a shot, they could maneuver him until he would be forced to descend through lack of gasoline.

Harvey Mason recognized his adversary's new determination. It added to his own danger and the peril of his native land. Yomomato must not be allowed to escape with the photographs he had obtained. More than a year's secret labor in which the keenest minds in the Navy had taken part would be made useless if this man succeeded in making his base with these films. A new decision hardened the young American's face, a decision to sacrifice his career in the Navy rather than permit his country's defense to be imperiled. Yomomato had heard Commander Jacobson's orders. He was taking chances he would not otherwise attempt.

The American waited. He would not engage in a long battle. One burst and the Kawasaki would be shot down. He stepped his motor up to its highest pitch, then went into a loop that brought a bellow of protest from the straining Cyclone. Yomomato answered with a wing-

(Continued on page 86)



All Questions Answered

This section of FLYING ACES is at your service, F.A.C.'s. Send in your questions and requests for aereo information, and we'll be glad to answer them here in the order they are received.

* * *

Melvin Carro, Revere, Mass.:—As far as we know, the Berliner-Joyce two-seater does 154 top. The top speed of the Consolidated P-30 is said to be 230 m.p.h. We have no official data on the Northrop Attack plane. We are trying to offer as many pictures every month as possible.

Robert Walter, Baltimore, Md.:—If you are a regular reader of FLYING ACES why do you ask questions that have been answered so many times? We have a few back copies of FLYING ACES. Let us know what months you desire. We cannot give you the addresses of those German airmen, as many of them you list are dead and the rest we have no trace of. Baron von Richthofen flew both the Albatros D-3 and the Fokker Triplane. The U. S. Air Service used the red, white, and blue insignia of the Allies during the war, but they used it with the white spot in the center and the red circle on the outside. The Northrop Aeroplane Co., of Minneapolis, Minn., advertises that they have war souvenirs for sale.

Roscoe Anderson:—I have read that story about the "Seven Sisters" but have no way of certifying who flew the planes. Why not write to the author c/o the publisher of the book and ask her to identify them for you?

Ralph Hartson, Warren, Ohio:—Gyner's Spad-Cannon fired its shell through the hub of the prop. Several other ships used the idea, too.

James V. White, Detroit, Mich.:—Terminal velocity refers to the highest speed a plane will make in a vertical dive with the engine full on. Power-loading refers to the ratio of weight carried to the horsepower of the engine used. The Buzz Benson stories are pure fiction based sometimes on actual incidents or items gleaned from newspapers.

Lloyd Vaughn, Washington, D. C.:—If the All the World's Aircraft you were inspecting did not have the details on that L.V.G. single-seater, I do not know where you can get them.

Ralph Tarullo, Somerville, Mass.:—The "NC" before the license letters on aircraft is the international designation of ships licensed in the United States. It does not mean Navy-Curtiss.

Kenneth A. Clark, Fulham, England:—We are sorry the David Martin articles did not please you, but as was stated very clearly, only actual commissioned planes—machines in actual

squadron service—were considered in the résumé. We do know all about the new Seals, Wellesleys, Spitfires, Hawker monoplanes, Gladiators, and Bristol bombers—but they were not service equipment at the time the article was printed. Indeed, few of them have actually been built as yet. The same method of treatment was employed by Mr. Martin in the accounts of the air services of other nations.

Ken Littlepage, LaMott, Pa.:—We do not know why the Curtiss "Swift" has not been officially accepted by the Army Air Force. No official reports have been given out on it, as yet.

Peter E. Batchelor, Brighton, Sussex, England:—Your story about Wallace Beery is very interesting, but I do not believe it is true. We have no record of his ever having been in any air service during the war. It sounds like movie publicity, although Beery does fly a lot now and has his own plane. The Holland Fokker plant is in Amsterdam and letters addressed there will reach the firm. Why do they call Englishmen "Limeys"? Well, they say that in the old days, British sailors were given considerable lime juice to drink to prevent scurvy. American sailors who came in contact with them somehow picked up the gag and called them "Lime-juicers" and it eventually became "Limey."

Connell R. Miller, Dallas:—Thanks for your kind invitation to visit the Texas Centennial Exposition. If I can get down that way this summer, I most certainly will look you up. I would very much like to see it. Yes, I know all

about Love Field, but have never had an opportunity of writing anything about it. Sorry to hear you miss the Anthony Mainbearing drawings, but I think they petered out. He was a good guy while he had it—but he flew too long. Many thanks again!

Donald Failing, Fort Plain, N. Y.:—I don't quite get your argument concerning von Richthofen and Fonck. I can't tell you why Spads seem so popular in fiction stories, for in action they certainly did not compare with the Camel, S.E.5, or the Fokker D-7.

D. Wood, Gravesend, England:—Sorry, but we do not know the true air strength of the British Empire, and perhaps those in London don't actually know for sure either. Things are changing so fast over there, that it is impossible to make any reasonably fair statement on their air strength. We cannot publish pictures clipped out of magazines. We must have the actual photograph. Thanks for the clippings nevertheless.

Billy Sayle, Waukegan, Ill.:—Yes, I think you can purchase a service type machine if you have the money, but you cannot carry guns on it. What the dickens do you want one for? Starting a war on your own? We have seen dozens of kits for aircraft carriers. Why not read our advertising columns. Try Megow's, Howard and Oxford Streets, Philadelphia, Pa. The two movie actors you mention are not licensed pilots. Fog is made with special smoke in movie sets. The crash you saw in "Ceiling Zero" was an actual crash staged by a stunt man. When fighting planes fire at towed targets they use real ammunition, not blanks.

Paul Jones, Olive View California:—Write to the Ziff-Davis Publishing Company, 608 S. Dearborn Street, Chicago, for the booklet on building the Flying Flea.

Eugene Grib, Blyville, Arkansas:—Sorry, we have no "dope" on the two service ships you mention. The fastest pursuit—single-seater—in the world is said to be the new Vickers-Supermarine Spitfire which does about 325 m.p.h. But it has not been accepted by Britain as yet.

Clifford Carter, Los Angeles, Calif.:—We can't help it if you will get into these arguments. We cannot give out the speeds of service machines, for the simple reason that we do not know them.

(Continued on page 69)

And Now We'll Ask You a Few

- 1—Who flew the first pouch of air mail in this country, and when?
- 2—Who was the first licensed woman pilot in the United States?
- 3—Who flew the first plane off a catapult in the U. S. Navy, and when?
- 4—Name the Canadian airmen who won the Victoria Cross.
- 5—Did Col. Charles A. Lindbergh win the Congressional Medal of Honor?
- 6—Who were the "Three Musketeers of the Air"?
- 7—In what branch of aviation does the United States Navy lead?
- 8—Blind men were recruited during the war by the Defense of London Staff. What for?
- 9—Who was the first woman to fly the Atlantic Ocean?
- 10—Who is the most noted plane-crasher in the movies?

Answers on Page 95

HAPPY LANDINGS

BY ARCH WHITEHOUSE

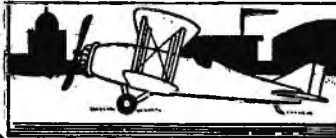

The War Plane Becomes a Winged Gun!

Recent developments in the armament field leave aircraft designers with many new problems. How can the single-seaters compete with the new high-speed bombers that are armed with automatic cannons? So asks Mr. Whitehouse, who this month describes the latest handiwork of the airplane weapon makers.



A FEW years ago, military aircraft designers were suddenly confronted with a problem. Two-seaters were too fast for the guns they were armed with! It was discovered that a gunner in the back pit of the modern two-seater, travelling at 200 m.p.h., was unable to train his gun efficiently on any target, owing to the unreasonable amount of slip-stream pressure he had to combat in his normal "working" position.

The experts had to admit that an observer attempting to fire over the side of his turret at a target off his wing-tips, for instance, invariably found himself putting in more effort to keep the gun pointing out sideways, than in actual gun-laying for accuracy. In many cases the gun was literally swept out of his hands and spun around in such a manner that he actually fired toward his own tail—which certainly wasn't healthy.

Thus, the two-seat fighter—which had become a real menace to the single-seaters because of excellent maneuverability and wide angles of gun-fire—suddenly lost much of its inherent value.

But all this has been changed in the last two years by the general acceptance of those glassed-in gunner's cockpits, usually referred to as "greenhouses" or "bird-cages." These cages have even been added to many single-seaters in an attempt to compensate for that old bugaboo "blackout" which affects pilots in sharp turns or pull ups when the ship is doing anything like four miles a minute. Whether it is centrifugal force that drives the blood from the brain under such speed, or simply the general air pressure, has not been fully explained. However, the greenhouse appears to be here to stay—at least as far as the gunners are concerned.

NOW we come to a new problem—that of the big guns mounted in the heavier types of planes and in some cases in the single-seaters.

You see, the gentlemen who think up new and brighter ways of shooting down flying men have decided that ordinary machine guns are no longer sufficient. For one thing, m.g.'s have only a comparatively short range; and when we consider the speed of the modern ship, the pilot or gunner can only draw a bead on an enemy target for a few seconds. After that he is out of range. It was all right in the old days when single-seaters did about 100-120. Then the pilot could nose down on his target from about 200 yards and open fire. He did not have to pull out until he had fired a good burst.

Today, it's different. With single-seaters diving at anything between 300 and 400 m.p.h.—and considering that they are still using similar guns—there is but a few seconds to aim and press the trigger. Actually, the worth of the machine gun has been cut to one third the actual value it had in 1918. Figure it out yourself.

And so, there is nothing to do but to improve the guns. Thus the development of the aircraft cannon which has a greater firing power and added range.

They tried the cannon idea back in the war days, but it was never really successful, in spite of all the glory stories that have been written about its use by Norman Prince, Georges Guynemer, and Rene Fonck.

The first *real* aerial cannon came out a few years ago and was mounted on the British Blackburn Perth flying boats. It was originally intended for action against submarines and no doubt still is, as far as the Perths are concerned. Of late years, however, the same guns (1½-pounder automatic Vickers-Armstrongs) are being mounted on new high-speed bomber-fighters. They fire 150 rounds a minute and the shells come in varying types, depending on the work involved. Some are armor-piercing and other are graze-fuse shells that explode on contact with anything equal in body to the fabric of an ordinary wing.

Next we heard of a long list of ships—mostly single-seaters—fitted with the Hispano-Suiza *canon*, a 20 mm. gun set to fire through the hollow prop boss. You have read plenty about that in other departments of this magazine.

And now we get a new one—the American Armament Company's new 37 mm. automatic cannon which fires an explosive shell accurately at a range of anything up to 1,000 yards. The new Boeing Bomber will be fitted with one of these new guns and that will give you some idea where a single-seater handling guns that are only reasonably accurate in the air at 400 yards will get off.

The pilot won't even get time to "get off"—he'll be blown off!

OF course the news stories appearing in the papers about the new A.A.C. gun invented by a man named B. P. Joyce, have been pretty spotty and unconvincing. Few newspapermen seem to know the first thing about aviation guns—that is, guns of this type—so if you have read anything about it, you are probably still puzzled. (A.A.C. means American Arms Corp.)

For instance, the reporters went into raptures about

the recoil business of the Joyce gun, not knowing that practically every machine gun worth the name solved the recoil problem years ago. They have to absorb the recoil action to carry out one of the important movements of the mechanism.

The Joyce gun, from the experts' angle, seems to have solved an important point in its gun-barrel length. Where the European guns are generally ungainly, the Joyce gun is comparatively short and appears to be very mobile from an ordinary turret.

The cannon used in the French His-

pano-Suiza has an effective range of about 500 yards. The British Vickers gun also appears to have a good range, but is very ungainly for use under emergency conditions. It requires a special turret and a specially trained gunner. It most certainly could not be moved around with any true dexterity in an air battle. The Joyce gun, on the other hand (judging by photographs we have seen of it) appears to be an ideal weapon for ease of operation and use in action. It fires 100 rounds a minute, or it can be arranged to fire short bursts or single shots. It appears to be

slightly lighter than the Vickers-Armstrong gun. It's properly mounted in a suitable gun turret, such as may be built in the Boeing Bomber, and it should be a weapon to revolutionize aerial warfare.

Thus, we see that the air battle of the future will turn out to be a long-range action affair. If the single-seaters are all equipped with cannons of the Hispano-Suiza type (which fire through the nose of the prop and not between the blades) we shall see formations of these machines diving on the broad-

(Continued on page 91)

"Going Places" in an Aeronca A Tip For Prospective Buyers Cub Sales Pick Up Those British Clubs Again Let's See Some Action, Fans!

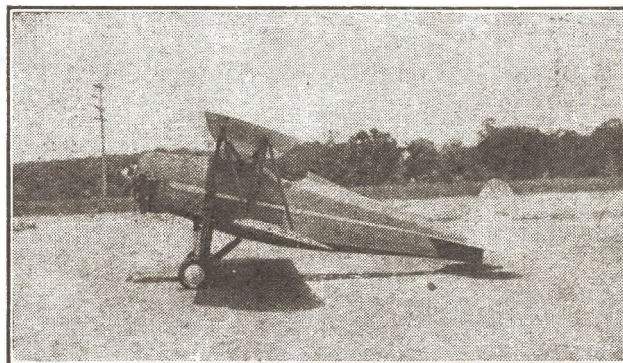

For \$975 flyaway Chicago, you can have this single-place light biplane. It's the Rose Farrakeet made by the Rose Aeroplane and Motor Co. of that city. Mounting the 37-h.p. Continental A-40 engine, it has a 100 m.p.h. top and a cruising range of 340 miles. A real plane, if you wish to fly alone—and why not?

On the Light Plane Tarmac

"GOING PLACES" IN AN AERONCA

THOSE who are under the impression that the so-called light plane is just that and no more, are due for a lot of shocks this year. If you think the light plane is something that just tootles about a cow-pasture landing field, you should come out from under and find out what it is all about.

Take, for instance, the recent "show"—and a very nice little "show," at that—of one Flying Officer David Llewellyn who bought an American Aeronca in England on February 6th. The next day, just for a lark, he climbed in and started a little trip across the English

Channel—and by March 1st he turned up in Johannesburg, South Africa!

He visited Lyons, Marseille, Pisa, Rome, Palermo, Tripoli, Sollum, Cairo, Wadi Halfa, Khartoum, Juba, and Kisumu. True, there were a few days here and there where Mr. Llewellyn simply disappeared, but no one bothered. You see, he had lots of friends on the route, and he wanted to show them his new toy.

Eventually, he turned up, brown and breezy, at Mbeya and flew on to Mpika. (Yes, there are such places and the names are spelled that way, which shows just what you can find out if you own a light plane.) Finally, he blew into Bulawayo, then landed at Johannesburg.

On one occasion he ran into a tropical storm (in Northern Rhodesia) and landed in a clearing. And once he had some trouble with his engine, but reports have it that he fixed it with the aid of a common, pocket nail file!

Now, I ask you—what are we waiting for?

A TIP FOR PROSPECTIVE BUYERS

IF you are looking for a good list of second-hand planes from which to make your selection this summer, get in touch with the Aviation Products Co., of 619 S. Federal Street, Chicago, Ill., and we are certain you will find something there



This Pietenpol Air-Camper is one for you birds who want to buy 'em knocked down. B. H. Pietenpol, of Spring Valley, Minn., makes them. The price complete is \$850, or as we have just said, you may buy the parts and assemble the job yourself. With the converted Ford Model "A" engine, the top speed is 90 m.p.h. The cruising range is 230 miles.

PILOTOPICS

By ROY HUMPHRIES



RUTH CHATTERTON, IS AN OUTSTANDING AVIATRIX AND IS THE ONLY ACTRESS TO HAVE PILOTED HER OWN PLANE ACROSS THE CONTINENT. . .



PILOT GETS THRILL AS GIANT METEOR SHOOT'S DIRECTLY TOWARD PLANE. . .

Roy Humphries



ROSES SHOWERED FROM PLANE LAUNCH NATIONAL EXHIBIT. . .



PARACHUTE JUMPER DEFIES ALL DEMONS OF FLYING SUPERSTITIONS ON FRIDAY THE 13TH

Stories Back of the Above Pictures

1—Ruth Chatterton, distinguished stage and screen star, is not only air-minded but also a first-class flyer. She is the only member of her profession who has piloted a plane all the way across the continent single handed.

2—Roses recently fluttered gently down from the skies upon astonished pedestrians in Baltimore. They cascaded from a plane piloted by Riall Jackson, son of Mayor Howard W. Jackson of the Maryland metropolis. The shower of blossoms was the signal for the opening of Baltimore's Seventh Annual Flower and Garden Show.

3—Jock Templeton, one of the crack pilots of United Airlines, received the thrill of a lifetime recently while at the controls of one of the giant passenger planes on the Cleveland-Newark night run. A dazzling ball of fire suddenly hurtled down upon his ship when he was about 75 miles west of Newark Airport. The fearsome object plunged directly toward his craft, seemed about to strike it, then veered sharply. After landing, Templeton learned he had witnessed the fall of a great meteor.

4—Louis A. Barr, 27 year old air enthusiast and a member of the Washington Parachute Club, can't be bothered by ill omens or superstitions. He chose Friday, March 13, to make his thirteenth parachute jump and even went to the extent of picking his bail-out time at exactly 13 minutes to 6 p.m. Moreover, before climbing into the ship to make his leap from the 13,000-foot level, he casually performed the following rites: took the third light from a match, walked under a ladder, stepped over a broom, spilled some salt, induced a black cat to cross his path, and—greatest ill omen of all for superstitious airmen—climbed into the plane from the starboard side! P.S.—He nevertheless made a perfectly safe chute landing!

that will fill your need. They have an Aeronca C-3 for \$875.00, a Lincoln Primary trainer for \$1,200, and a Fairchild KR-21B for \$1,685. They have rebuilt engines and glider parts, too. Major H. H. Woeltjen is the manager in charge. If you have blueprints for any light plane, send them through to the Major and he will give you a quotation on the parts required, so that you can put them together yourself.

CUB SALES PICK UP

PERSONALLY, we like the new Cub —the new Taylor Cub, we mean. They are putting out an improved model this year, you know, and from what we can make of it, they have found what the boys want. They have enlarged their plant to twice its size. They built twelve ships during the Month of February—and sold every one. The Taylor Aircraft Company is at Bradford, Pa., and that address will reach them.

THOSE BRITISH CLUBS AGAIN

APPROXIMATELY 100,000 people in this country want to fly. To do so they must purchase training at a recognized flying school. The Ryan School of Aeronautics, at Lindbergh Field, San Diego, just for example, will give you a private ticket course for \$585 or an amateur license for \$295. After that, you must purchase your own ship or you must buy solo time from a company that hires out planes for such purpose—because you must fly a certain number of hours every year to hold your ticket.

So what? None of us are quite certain what the answer is, but there must be one.

It may be found in the club idea, which for some reason has not yet clicked in this country. Nevertheless, in England—where gasoline is about 36 cents a gallon and where the A.B.C. Super Drone powered-glider costs \$1,375—they manage to organize flying clubs.

In fact, in the year 1935 twenty-seven British flying clubs had a membership of 7,738 and they trained 559 pilots and employed 117 aircraft! The Hampshire Aeroplane Club, for instance (where they enjoy considerable British fog) saw 2,051 hours of flying. Twenty-five members—in one year, remember—took their "A," or private, license; and thirty-five of the members took the blind flying course!

THE R.A.F. ADVERTISES

THIS week we noticed an advertisement in several British aero magazines inserted by the Royal Air Force officials.

It seems that they want pilots for the Reserve Air Force, which means that young men of good physique and reasonably good education can learn to fly service machines at no cost to themselves. Those of the applicants who already have their "A" license and twenty-five hours of solo flying will get first crack at this.

For the first year they'll get approximately nine weeks of training, and three weeks a year after that. Now,

(Continued on page 92)

With the Model Builders

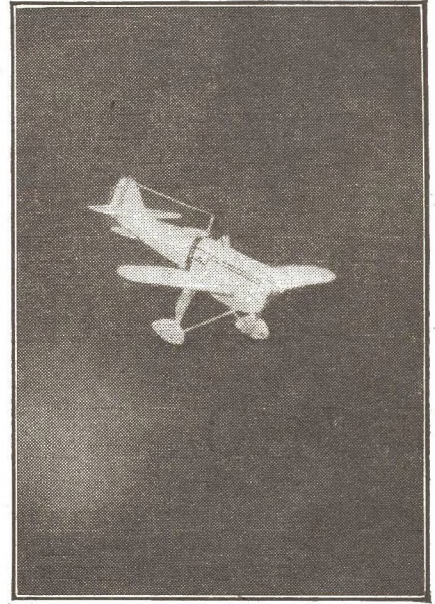
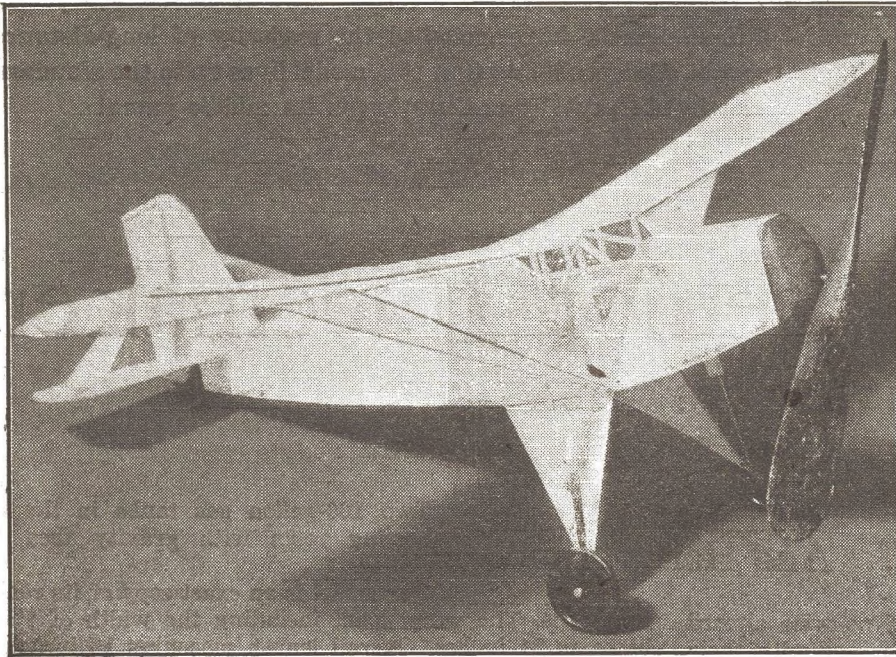

A French ship all the way from Britain! Fred G. Lewis, of Northampton, England, made this Dewoitine D-500 from plans published in FLYING ACES. It's complete even to the instrument panel. We like his photography, too. Thanks, Fred, we're holding your other photos for use later.

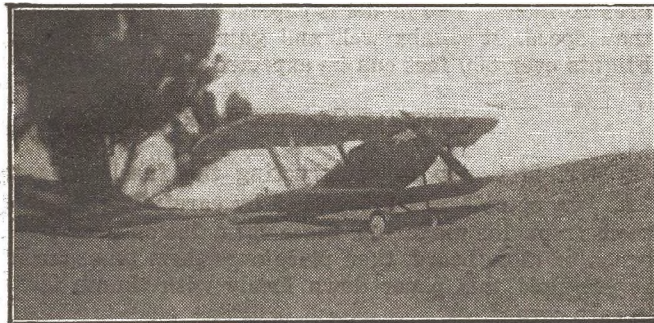

Above: This excellent photo of the Curtiss Robin was made by Bob Mitchell, of Benton Harbor, Michigan. He made the model, too, of course. It has, to quote Bob, a "free-wheeling prop," and it's made flights of half-minute duration. With that efficient propeller, it must be a great flyer, and it surely is a bright looking craft! Left: The German Roland pictured here seems to have landed in a desert, and at first glance you'd almost swear it's a real plane. Loren Hicks, of Salem, Oregon, built the model and laid out the setting. You nearly had us fooled, Loren!

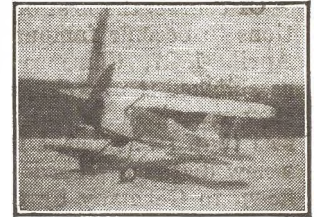

Alexander Morris, of Putnam, Conn., is the C.O. of this Curtiss Army Hawk. His photo wasn't as big as we like to have 'em—but you can see it's a great little flyer.

Right: Burton DeMaxan, of Salt Lake City, sends us this line-up of swell models. Burton has a Berliner-Joyce OJ-2 there, and third from the left is his FLYING ACES Utility ship. They're all flying jobs. Too close to that cemetery, though!

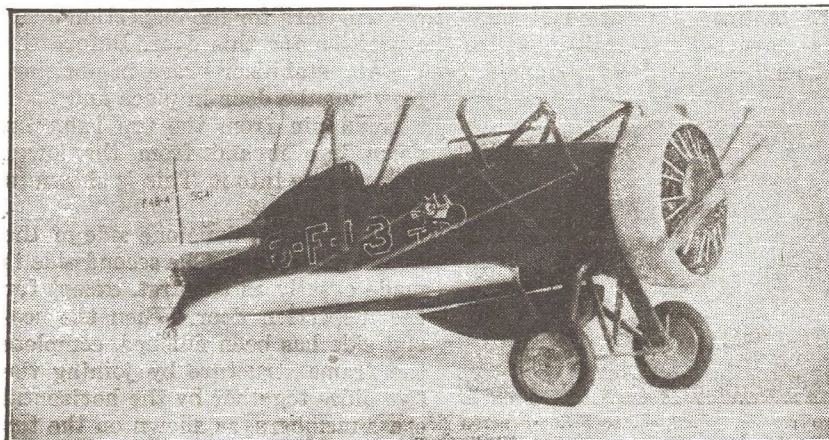
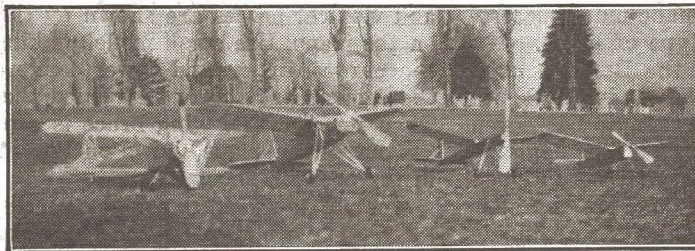

We know you'll like this Boeing F4B, which is equipped with a belly tank and boasts full squadron insignia. It was turned out by Norman L. Avery, of Primghar, Iowa. Norm's workmanship shows rare patience, and he capped it off with a nice paint job. Note the excellent detail work in the cowling and engine.



Here's the personality snap of the month. It shows Roy Belotti, of Los Angeles, with four of his models. He has a smart Howard "Ike," a good-sized Fokker Tripe, a Nieuport 27-C1, and a tiny Gee Bee racer. And you've got to admit that Roy is a pretty nice looking guy, too!

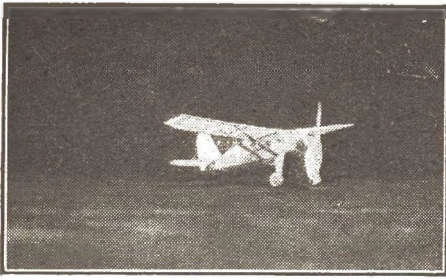

First off, cast your eyes over the author's original model of the Senior Pacemaker. We'd say it's a plenty nice looking piece of workmanship—and she flies as well as she looks! You could "spot" those famous Bellanca lines a mile off.

* * *

Ever since Clarence Chamberlin flew the renowned "Columbia" from Roosevelt Field to Germany, Bellanca planes have been esteemed the World over. So this month's feature model—the latest in this famed line of ships—is sure to strike a responsive chord with every real model fan. Bellancas have smashed the majority of long-distance flight records. And you'll find that this model lives up to the standard set by its prototype. Duration is its middle name!

* * *

Build the Senior Pacemaker

BELLANCA'S GREAT SHIP

* * *

THE distinctive design which has made Bellanca planes famous has been retained through all these many years of its manufacture. Improvements and modifications have in no wise altered its fine flying lines. The long narrow wings with their curiously chopped off ends, the narrow tail, and the high rudder have made the Bellanca plane a familiar sight to everyone interested in aviation.

Of course, the first of Giuseppe Mario Bellanca's creations to become famous was the sturdy "Columbia." In April, 1927, Clarence Chamberlin and Bert Acosta established the World's duration record in this job when they remained in the air slightly over 51 hours. And less than two months later it was destined to hang up a new distance record—3,923 miles—made when it was flown to Germany by Chamberlin and Levine.

The "Columbia" was the first of the Bellanca tribe to win aerial laurels. Since then, Bellancas have established a majority of the world's long distance records, load carrying flights, etc., and have made more successful ocean crossings than any other type of plane.

The Senior Pacemaker, newest of the Bellanca clan, is powered with a 420 h. p. Wright Whirlwind E-Series engine. As a commercial passenger craft, it has seven seats for passengers and one for the pilot. The baggage compartment is in the rear of the ship. It is equipped with a throw-over type control column. The landing gear is of the full cantilever design with oleo struts inside the fuselage.

The wheels are brake controlled and are streamlined. All windows are shatter proof. For freight purposes the seats can easily be removed and an additional seat for a co-pilot may be added with an extra pair of rudder pedals. This type of ship is also convertible into a seaplane.

Following is additional data:

Span—50'

Length—27' 11"

Height (Landplane)—8' 6"

Top speed—170 m.p.h.

Cruising speed at $\frac{3}{4}$ h.p.—145 m.p.h. at 12,000 feet

Rate of climb—900 feet per minute, full load

Cruising range—1,180 miles

Direct drive electric starter

By Jesse Davidson
And Harry Appel

Two 100-gallon gas tanks in the wing roots with gravity feed flow.

Our model is an exact copy of its real prototype. The wing span, including the width of the body, is 24 inches. Overall length measures 13 inches. Landing gear tread is $5\frac{3}{4}$ inches. Elevator span measures 10 inches. The model is capable of more endurance than speed. It climbs well and gains altitude rapidly. Flights over 600 feet can be expected consistently.

FUSELAGE CONSTRUCTION

THE first step in constructing the fuselage is to join plans 1 and 2 together by carefully removing them from this magazine. Place them flat on your work bench or table board, then place over them transparent paper. Hold this paper down firmly with thumb tacks in each corner.

Build one side of the body at a time. The longerons and vertical braces are shown by the jet black outlines on the plans. Use small model making pins to help keep the curved upper and lower longerons in place until the cement has thoroughly dried the vertical members. Then remove. The wing brace is a piece of sheet balsa cut out to the shape shown on Plan 4. This is cemented in the position shown.

The window frames are also pieces of sheet balsa cut to the shape shown by the black patterns. After they have dried, place celluloid windows in their respective positions. Plan 4 shows a pattern for the inspection door. Plan 2 indicates the position for this door. Before the door is hinged, cement the stabilizer brace in position.

Now put the door in place and push a small pin from the top longeron down into it and from the lower longeron up into it. This is shown in detail on Plan 2.

When this is done one side of the body is completed. The second side is made exactly as the first, except for the inspection door. When the second side has been finished, complete the frame structure by joining the two sides together by the horizontal cross members, as shown on the top view drawing. For every cross member shown on the top view, there is

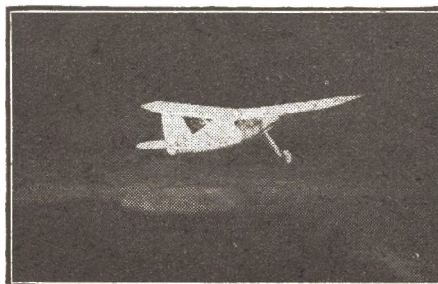

This rear-quarter "shot" of the Bellanca model illustrates the broad "stride" of the undercarriage. The photo looks like a snapshot of a real plane landing at night on a floodlighted airport.

FULL PLANS FOR THIS FINE MODEL APPEAR ON FOLLOWING PAGES

one which is cemented on the bottom part of the body directly beneath it.

Use small model making pins to help you obtain the gradual curve towards the tail. Later remove the pins. The nose is curved slightly inward to the width shown by the black lines in F-1. Former F-1 is built around the forward end of the body. Directly behind it and underneath is F-2, and so on down the line to F-9.

Before cementing the stringers in place, cement the shock absorber support in position. It lies flat between the body sides and extends the distance from F-2 to F-3. At this time it is necessary to shape (from .016 wire) the shock absorbers 1 and 2. Their shape, length, and method of installation are shown in detail on Plan 3. No. 1 shock wire is cemented on top of the support and No. 2 below, as shown by the dotted lines. After this important fixture is cemented in place, run the stringers along the bottom of the fuselage and merge them neatly at the tail point. Sand down to smoothness.

Former F-9 is made of two pieces of balsa laminated cross-grained. Then the wire rear hook is inserted. Apply cement well at the connecting ends of this former, for a lot of strain is imposed upon it. Former F-10 is cemented, as shown, directly in front of the windshield. Small size stringers connect it to Former F-1. Sand down the rough spots and make all the joinings rounded.

The motor cowling is constructed in three parts. Two pieces at the front are made of 3/16" balsa laminated cross-grained with the space cut out to accommodate the nose plug. The third part, letter "A," is shown in thickness and diameter on Plan 2. The plug hole must be cut out carefully so that it will fit snugly. When all three parts of the cowling are sanded to shape, apply cement generously, press the parts together firmly, and allow time to harden.

Meanwhile cut the nose plug to shape, as illustrated. Two brass eye-lets are inserted—one at the front, and one at the rear. Of course, a narrow hole must be bored through for the prop shaft. The tail wheel fork is shaped from wire, as shown, and a wooden wheel mounted and cemented in place. The fuselage construction is completed at this point, and you may now proceed to cover it with Jap tissue, using banana oil for the adhesive. Before doping, water-spray the body.

WINGS AND TAIL SURFACES

JOIN Plans 3 and 4 together in order to construct the wings. They are made in the

conventional manner. When they are completed, cover carefully and spray with water. The construction of the tail parts are simple enough. The outline frames are 1/16" flat. Cover the parts on both sides and water spray. Mount the parts, if you wish, at this time. Be sure they do not fall off to one side in the process of drying. White thread is used for bracing, as shown on Plans 2 and 4.

WING STRUTS, LANDING GEAR, PROP

THE wing struts are made in the manner shown on Plan 3. The projecting ends are made of white pine and are pushed part way into the balsa and cemented. They are, of course, streamlined, as are the struts, too. Note also how they are cracked at the lower ends to

(Continued on page 94)

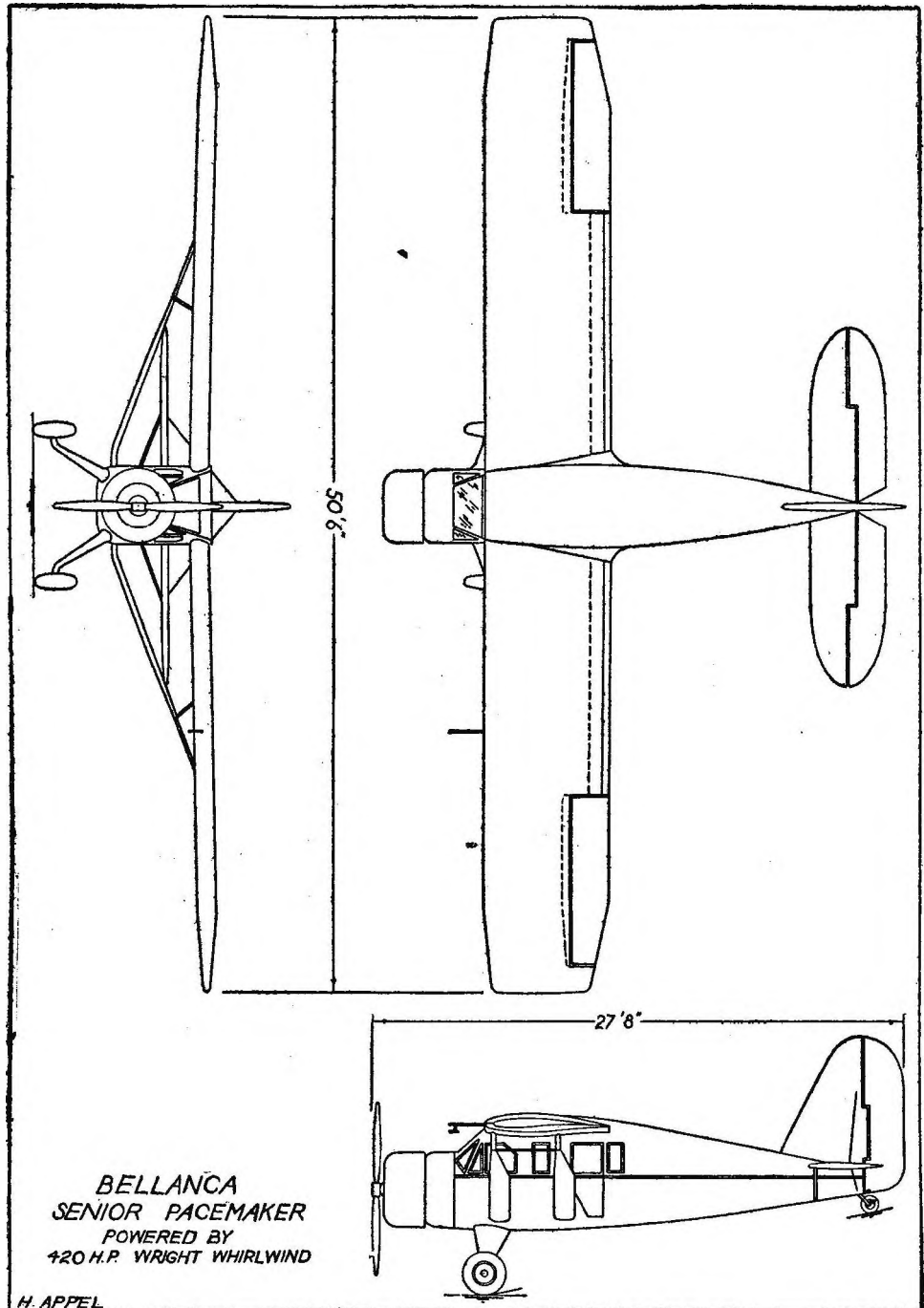

BELLANCA
SENIOR PACEMAKER
POWERED BY
120 H.P. WRIGHT WHIRLWIND

H. APPEL

We've included this three-view drawing of the real Bellanca Senior Pacemaker to aid you in building your model. The details of the complete ship, shown here, may be checked with the plans given on the following pages.

BUILD THE SENIOR PACEMAKER—Plan 1

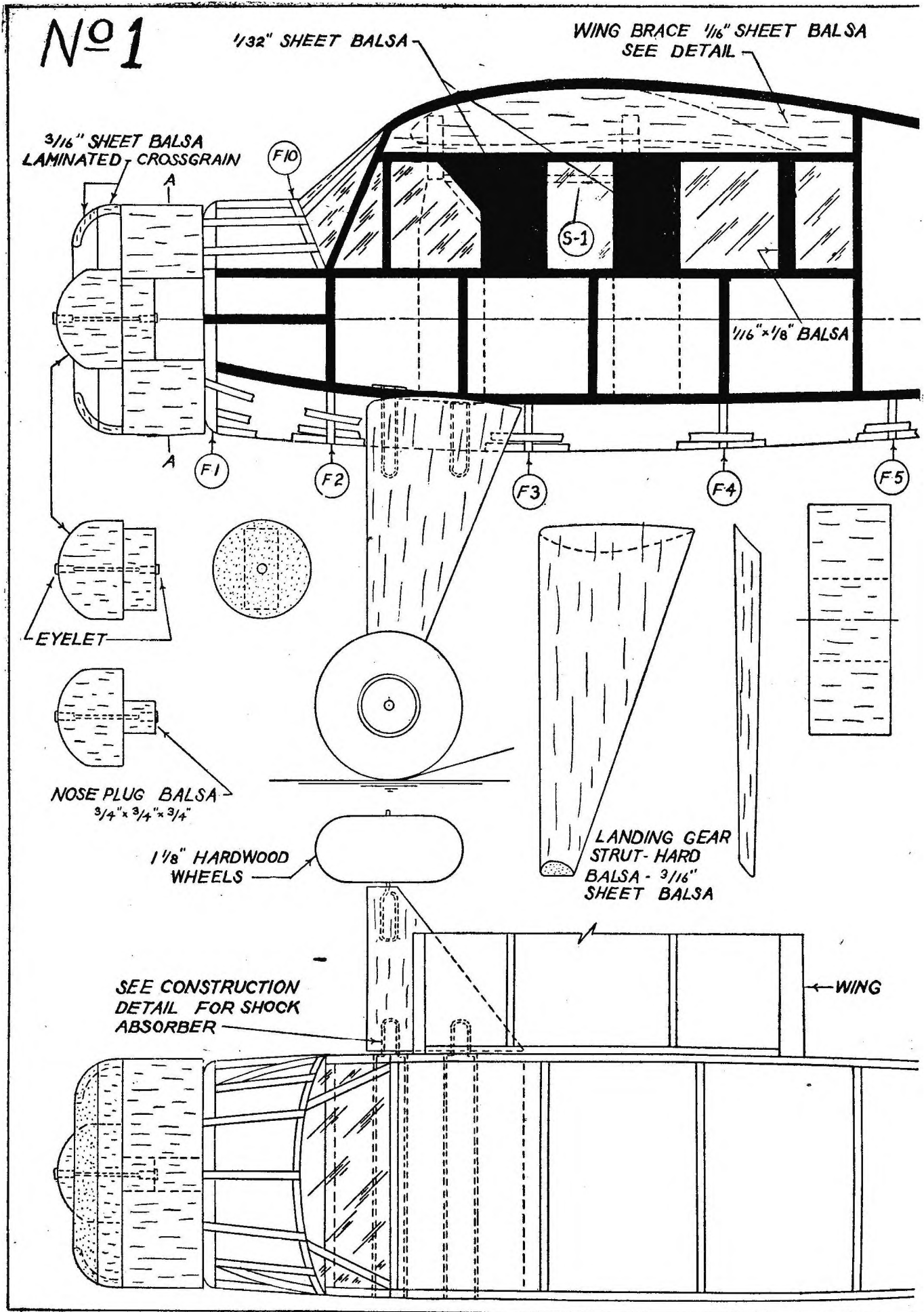

BUILD THE SENIOR PACEMAKER—Plan 2

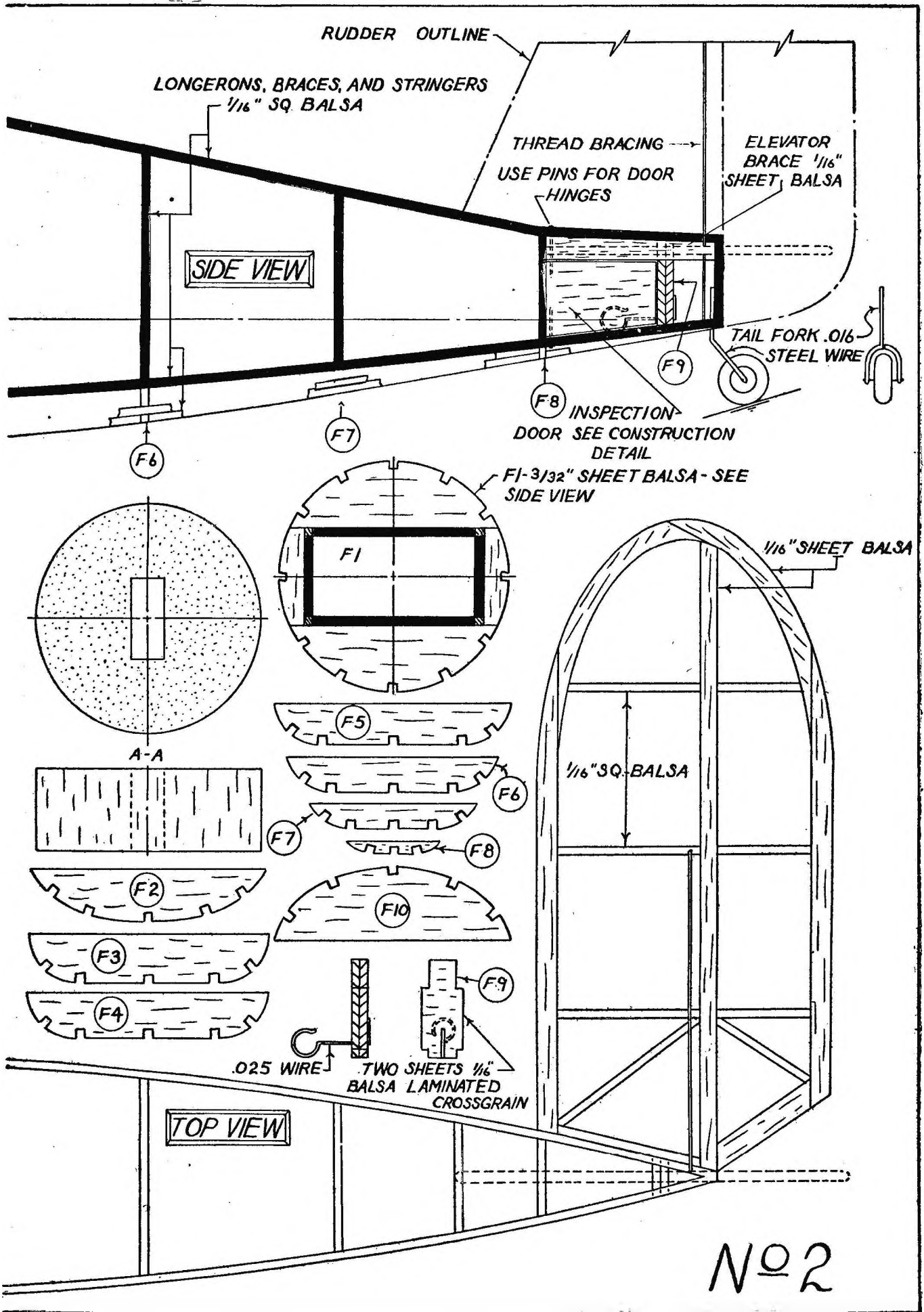

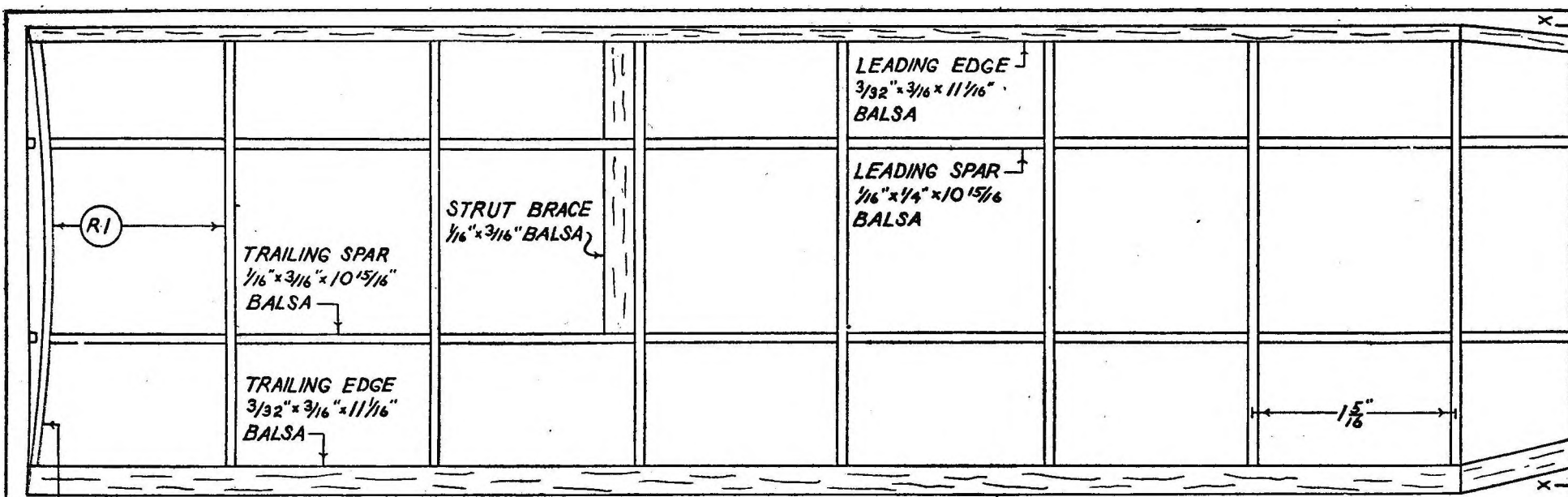

RIB SET AT ANGLE FOR DIHEDRAL PURPOSES

No 3

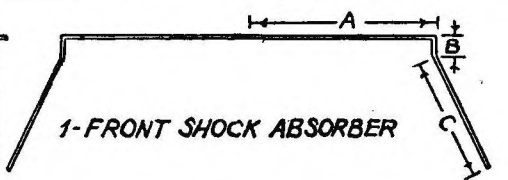
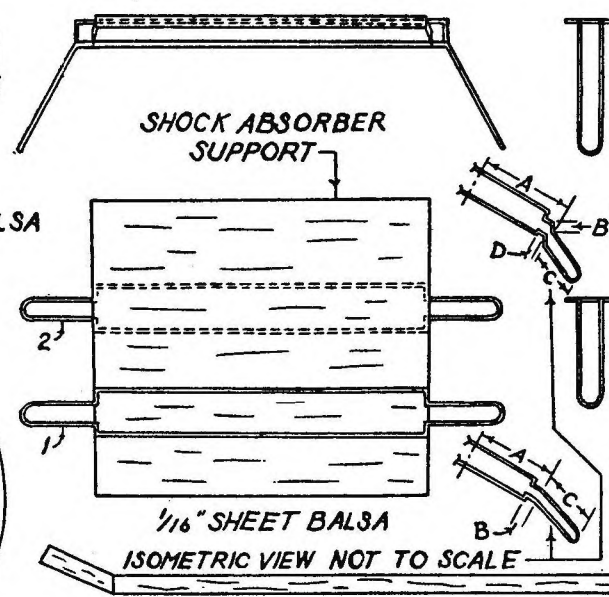
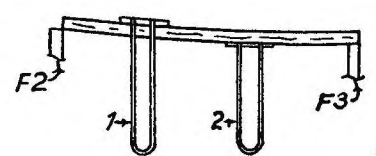
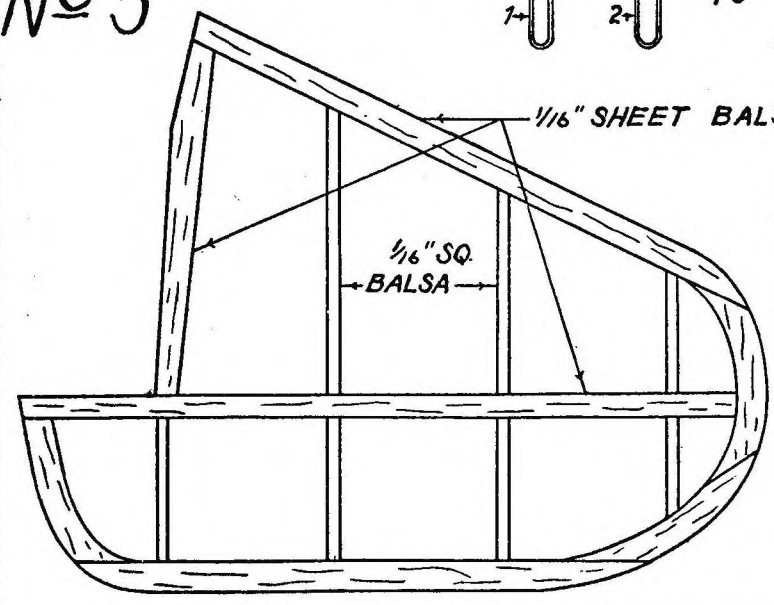

SHOCK ABSORBERS 1 AND 2
.016 STEEL WIRE 1/16" x 1/8" PINE

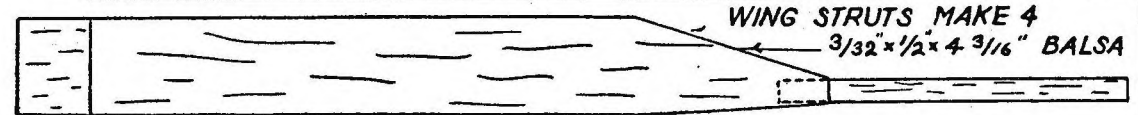

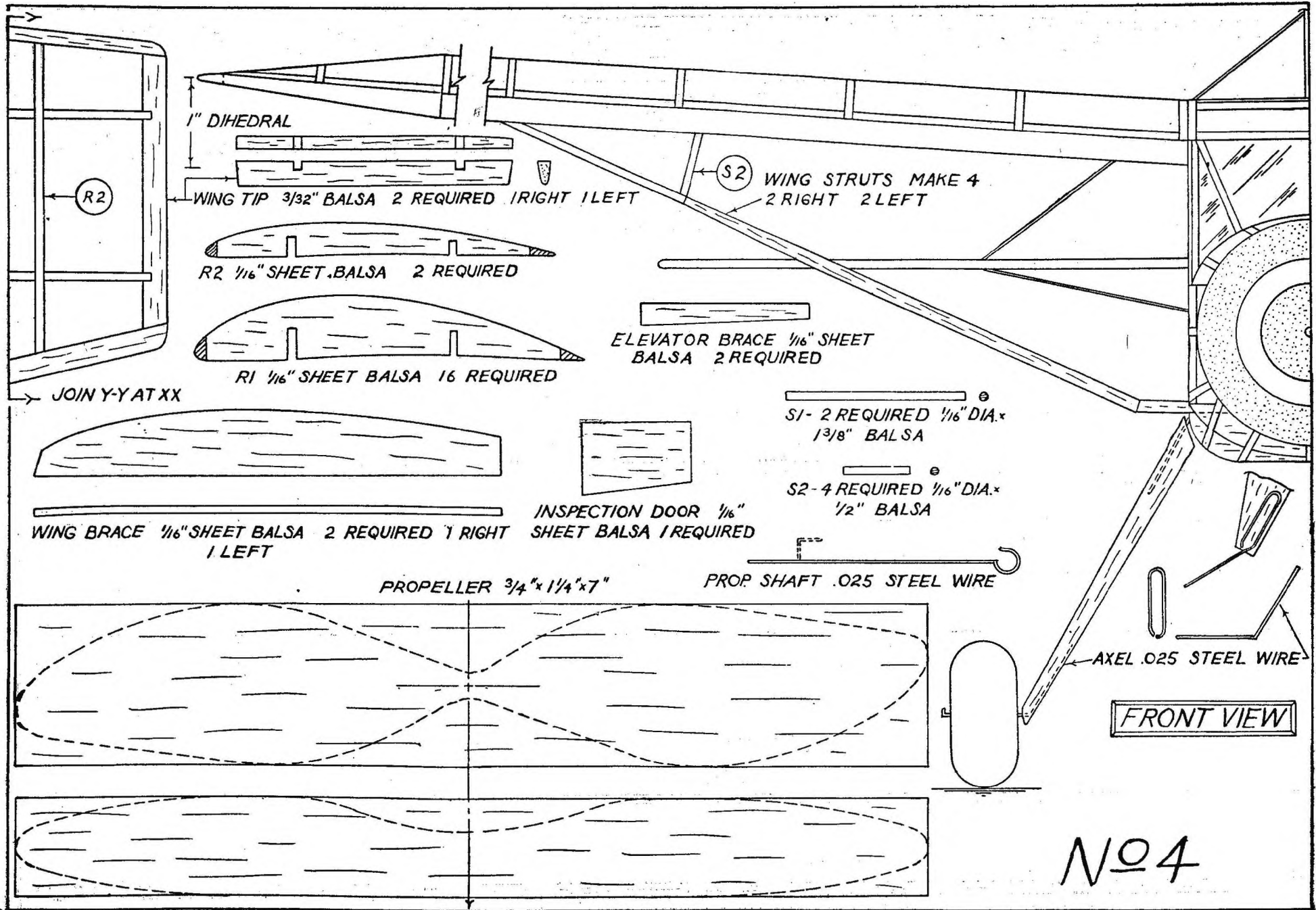

[37]

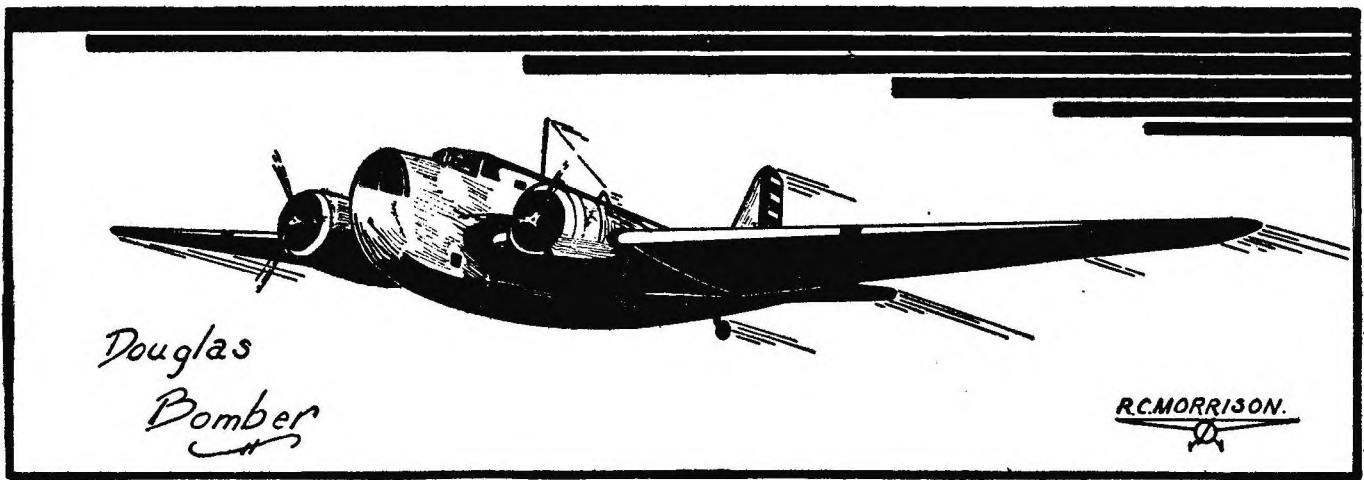

Make the Douglas Bomber

* * *

LAST summer at Wright Field, Dayton, Ohio, a huge, all-metal, mid-wing monoplane was undergoing strenuous tests by Army Air Corps pilots. Day after day, it could be seen, either in the air or on the ramp in front of its hangar being checked or overhauled in preparation for succeeding tests of its efficiency. But the public paid little attention to it.

The fact was that two other ships were also in the competition, and one of these—the Gargantuan four-engined Boeing Bomber—had won the lion's share of the public acclaim. In the eyes of the laymen, this great Boeing over-shadowed the Douglas and Martin ships with which it competed.

Nevertheless, it was the twin-engined Douglas BD-1 that "came through" and won a 90-plane order from our War Department! And this is the ship we are about to tell you how to build.

The Douglas BD-1 bomber is powered by two Wright Cyclone engines and is much like the famous Douglas DST's built for service on our airlines and is a direct development of the famous DC-2's of which 18 are also on order for the Army. The Douglas company, of Santa Monica, California, has had to double the size of its factory in order to build the new bombers. Six thousand men are to be employed.

Incidentally, these are not the only ships on order with Douglas. The Navy has called for 114 Douglas torpedo-bombers—three-place, low-wing planes of unusually clean design. Also under construction are 71 gull-wing observation planes, twenty huge 16-24 passenger DST's, many DC-2s for domestic and foreign use, and huge twin-engined flying boat into the bargain. Douglas is also busy on the plans for the first of its proposed four-engined transports which will carry 45 passengers. And now, let's get busy!

FUSELAGE

FOR building a scale model of the Douglas bomber, get dimensions from the accompanying plans and purchase your material. Use balsa wood in building the model. It may be purchased at any popular de-

partment store or model shop.

Draw the outline of the top eleva-

tion of the fuselage on your balsa wood and cut to shape with a jig-saw and sharp chisel. Go over the surfaces with coarse sandpaper. Then draw-on the side view and cut again. Round out the fuselage, as shown by the cross-sections, with your chisel. Always cut with the grain. Go over the newly cut surfaces with coarse, then fine, sandpaper until a smooth surface is obtained.

The gunner's pit in the nose and the pilot cab may be hollowed out if desired, and cellophane may be used for windows.

A retractable gun turret (as shown on plans on top of fuselage near the tail) may easily be built on the model. Hollow out the portion of the fuselage where the turret drops down. Make the gun turret of 1/16" sq. strips of balsa with cellophane as windows. Connect the strips together with model cement. The top of the turret should be made of very thin sheet balsa. Go over the entire fuselage with fine sandpaper.

WING

MAKE the wing in four sections—two stub portions holding engine nacelles and two outer sections. Draw the outline of the top view of these parts on stock and cut to shape with your jig-saw. Taper down the outer sections as shown on the front view. This may be done with a small, sharp chisel. Then shape out the airfoil, as shown by cross-sections G-G and H-H on the plans. Smooth off the rough spots (with coarse and fine sandpaper) on the four wing sections. The wing fillets—fairings where the wing joins the fuselage—may be made with putty or plastic wood after the model is assembled. Cut grooves in the wing stubs for the engine nacelles.

TAIL UNITS AND MISCELLANEOUS

THE tail units (fin, rudder, elevators, and stabilizer) may easily be cut from sheet balsa with a sharp razor blade. Taper down the units with a flat chisel, as shown by cross-sections and front view of the model. Sandpaper to smoothness with fine

(Continued on page 94)

Uncle Sam's sensational new master of the skies—the Douglas Bomber! That's one ship you've all been craving to wield your tools on, so clear your workbenches for action—here it is! And when you taxi your DB-1 off the production line, ring it in your camera sights and send us a "shot" for our "With The Model Builders" page.

HERE ARE THE PLANS FOR THIS GREAT SOLID MODEL

DOUGLAS BD-1 BOMBER

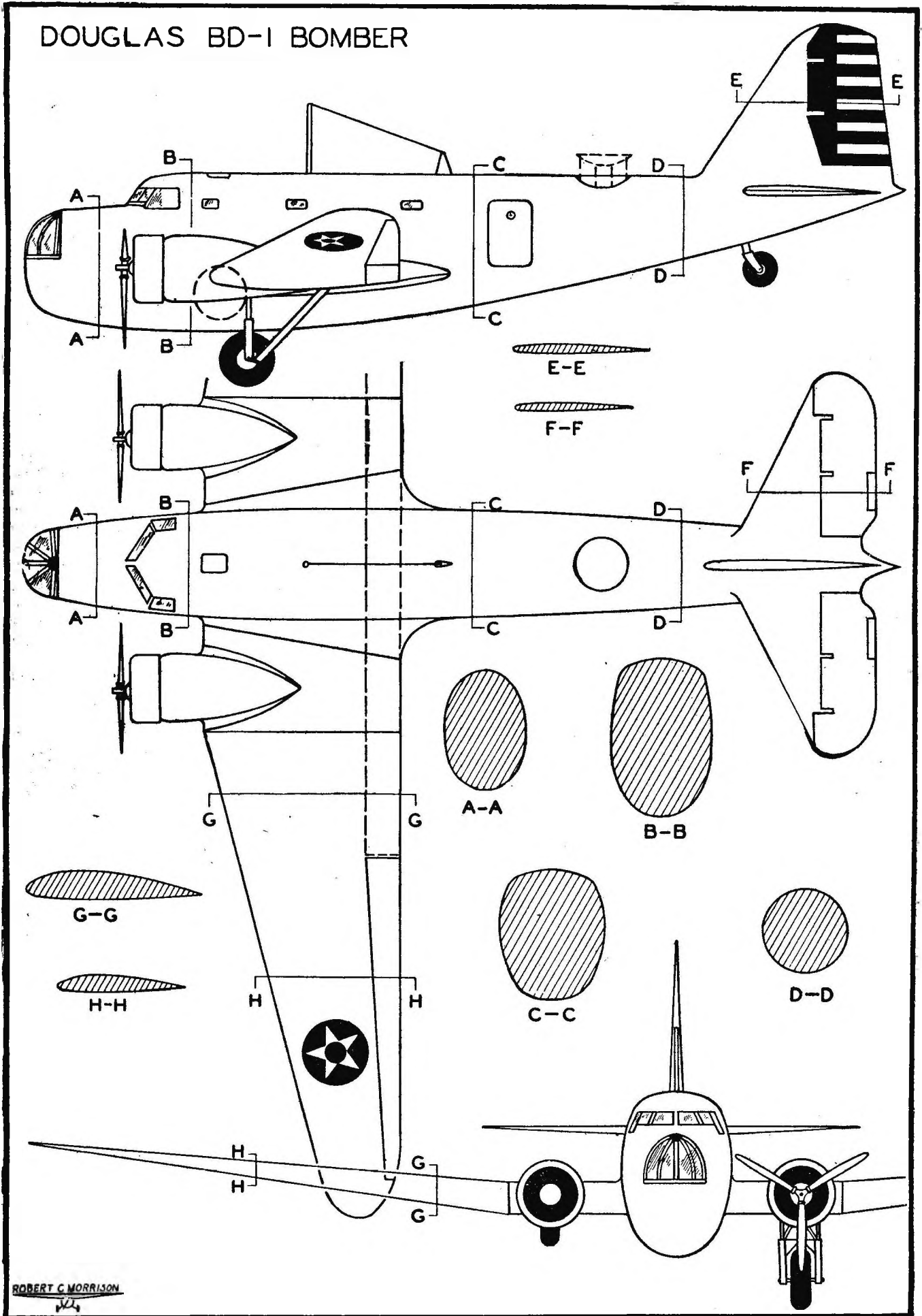

Try A Solid Model of the Bristol Type 120 Fighter

HERE'S a mighty neat craft whose trim lines and novel gunner's turret should prove quite a temptation to you fans who "go for" solid scale jobs. It's Britain's great Bristol 120, which is fitted with the

Bristol Mercury V1.S.2 geared and supercharged engine. Like its sister ship, the Bristol 118, it can be converted into a number of forms suitable for varied phases of war aviation. We present it as a two-place fighter.

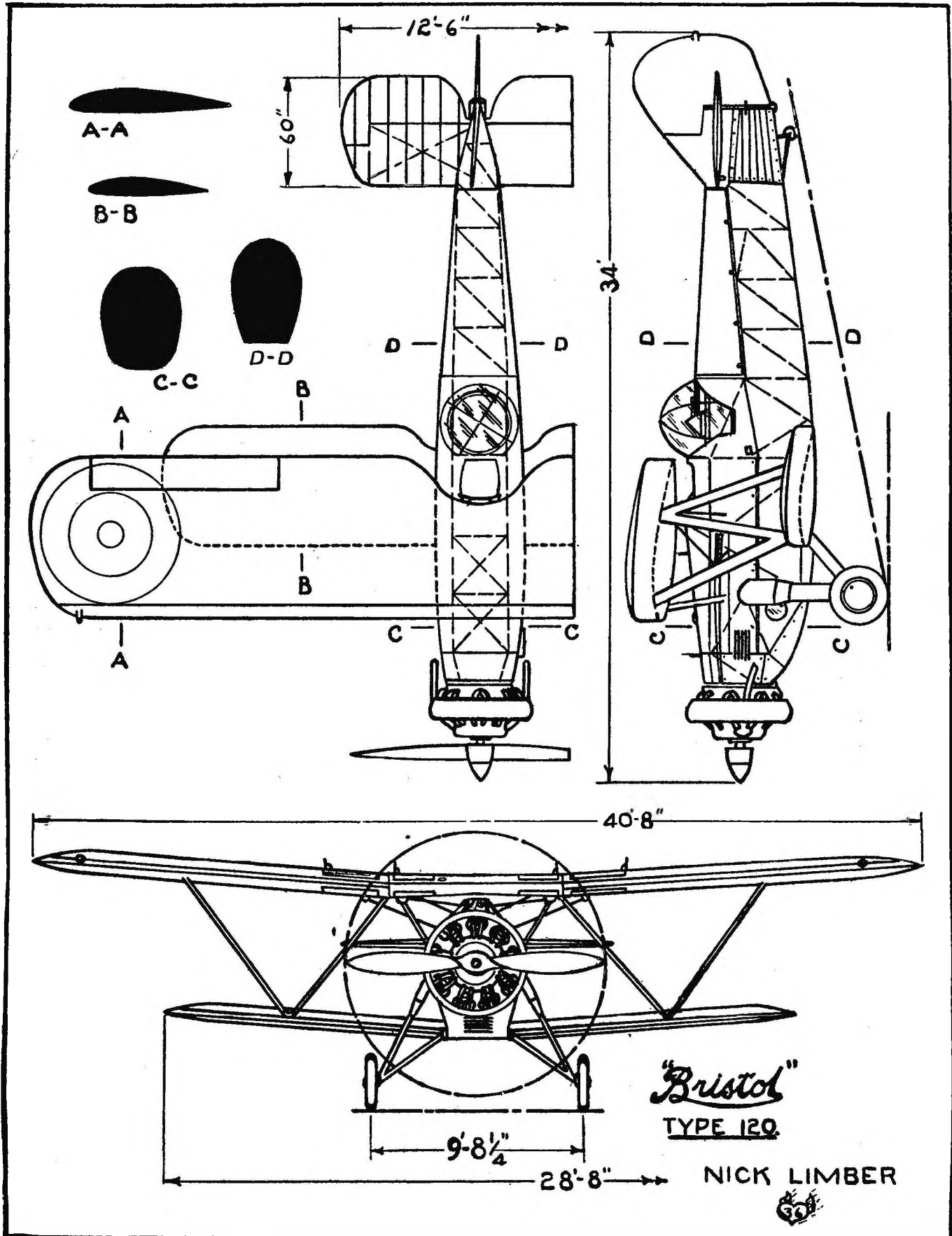

The Flying Aces Parasol

Three-point right here, fellows, if you're looking for a stick job that packs real performance—for that's just where the F. A. Parasol rings the bell! This swell model boasts several new features that are sure to go over big with you fans. It's from the workbench of Lou Garami, who gave you that snappy Indoor Moth in our May issue.

By Louis Garami

STICK models are a lot of fun. They're easy to build and easy to fly, and repairs are few and far between because the construction is simple throughout. These are the main reasons why stick jobs have always proved popular, especially with those builders who are just getting into the model game.

Now let us outline the design of our FLYING ACES Parasol. We want to point out a few improvements we've incorporated in it. First, we did away with the bothersome wing clips, since they wear and weaken the stick to a great extent, eventually causing it to collapse at the point of contact. Instead of clips we've got a bamboo strut arrangement here which braces the fuselage and at the same time allows the wing to be moved back and forth under the rubber bands, giving flexibility where it is needed. The built-up parasol wing, moreover, improves the ship's stability, both under power and on the glide. Finally, let us mention our use of aluminum tubing instead of the usual thrust bearing. This tubing is just as easy to attach and makes the propeller turn much smoother into the bargain.

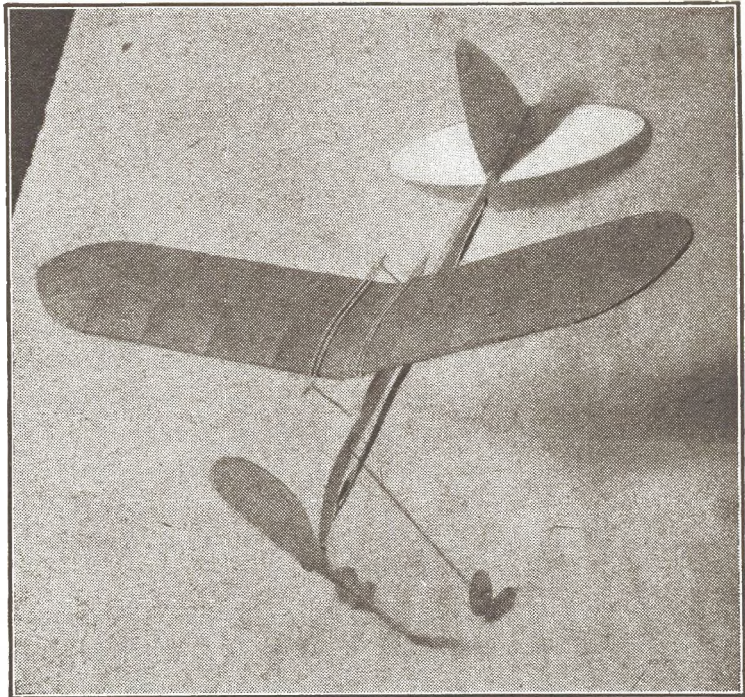

Just take a look at this sweet craft! She's certainly tops! And note that brand new parasol carriage arrangement that supports the wing. It takes the place of the bothersome wing clips commonly used on stick models. A great idea!

THE STICK

SELECT a medium hard $\frac{1}{8}$ " sheet balsa for the stick. Cut out and shape, according to the plan, and sandpaper the four edges lightly. Proceed by cementing the aluminum tubing and large $\frac{1}{4}$ " copper washer in place. Use plenty of cement and go over it again after the first coat has dried.

Now bend your landing gear out of .028 piano wire and saddle-shape it at the top so that it will fit the stick. Glue it very securely, repeating the dose. The rear hook, of the same size wire, has to be pushed into the wood and cemented.

You can easily make the wheels out of the same $\frac{1}{8}$ " sheet as was used for the stick. Mark them out with a pair of dividers, then cut out the two circles with a razor blade and sandpaper the edges so that they become more streamlined. Make a hole in the center of each with a pin and slip them on the landing gear, not forgetting to bend the wire up at the ends so that they will not come off.

The bamboo parts of your Parasol (struts and tailskid) are all $\frac{1}{32}$ " sq. The four stick struts

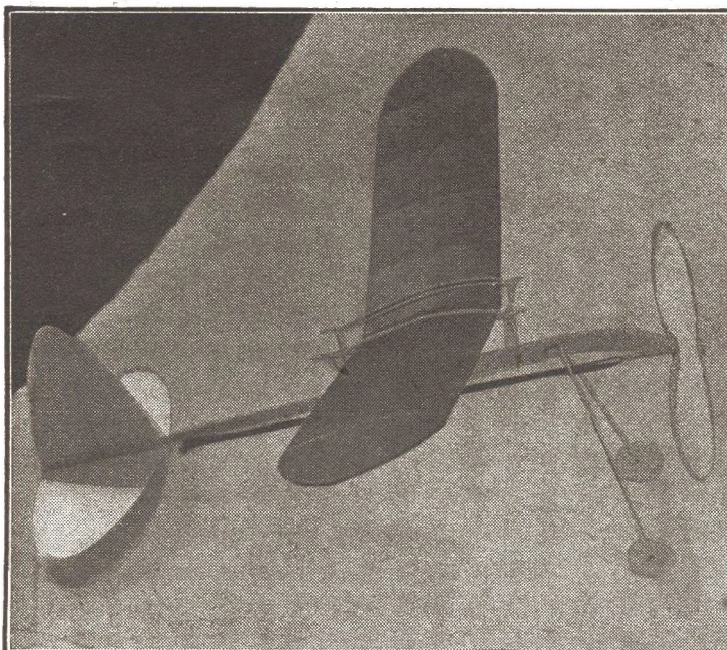

And here's an excellent side view that "brings out" the dihedral of the wing and shows the fine sweep of the stick-fuselage. Be sure, by the way, to put your rudder-fin on the left side of the stick. Mr. Garami had his on the right when these photos were taken, but that was because he was experimenting with the effects of torque.

FULL SIZE PLANS—

for this snappy parasol stick model appear on the following two pages.

have to be cut to even lengths, sharpened at one end, and pushed into the stick. Line them up from the side and front and cement them on. Next the cross pieces are glued on top of the struts so that $\frac{5}{16}$ " protrudes on front and rear (see plans). This is where the rubber bands will be hooked over the wing (see photos). These bamboo parts

(Continued on page 92)

THE FLYING ACES PARASOL—Plan 1

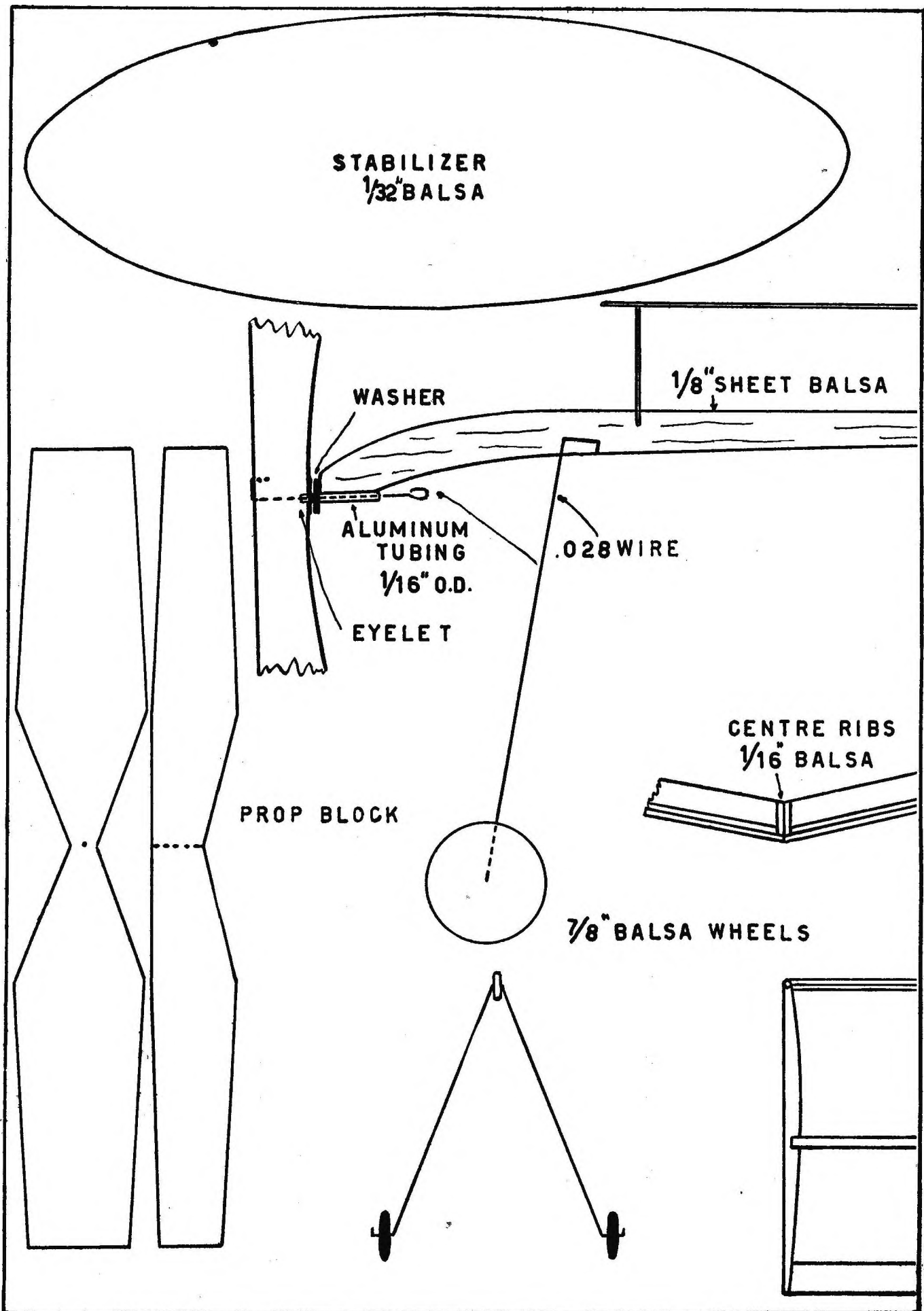

THE FLYING ACES PARASOL—Plan 2

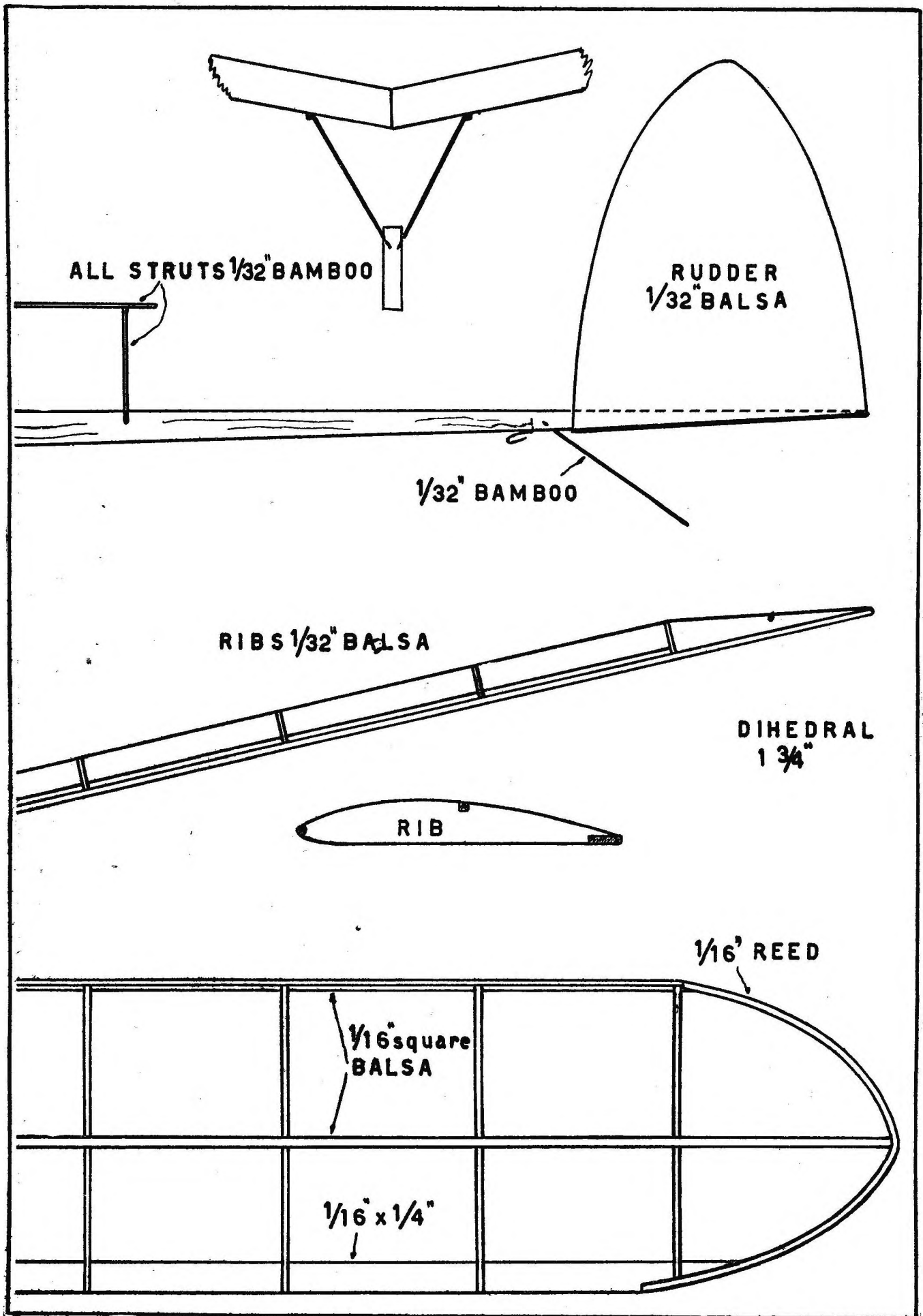

A beautiful piece of propeller workmanship! Read here how you can duplicate it.

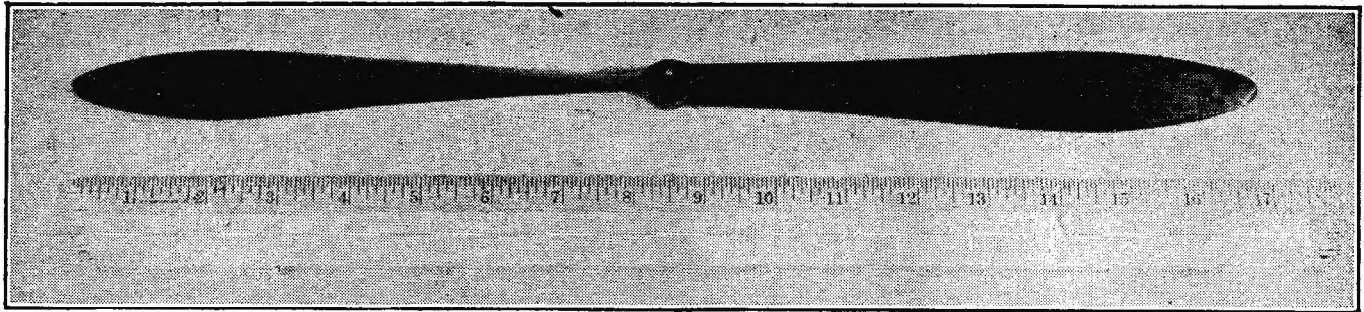

Flying Aces Model Laboratory

THIS MONTH'S GAS JOB ARTICLE—HOW TO DESIGN AND CARVE A PROPELLER FOR A FUEL-POWERED MODEL

By Avrum Zier
Model Department Editor

IN our last installment we discussed the essentials of the propeller theory. It was pointed out that a propeller is nothing more than a rotating wing under the influence of a forward and rotational velocity. The resultant of these two velocities acts upon the blades of the propeller producing a forward thrust in the same manner as the airstream acts upon the wing producing a lift, or a upward thrust.

It was further shown that while the forward velocity—which is the velocity of the airplane—remains a constant value, the rotational velocity varies as the distance from the center of the propeller to each point on the blades, the greatest velocity being experienced by the tip of the propeller. Because of this, the angle at which the resultant of the two velocities strikes the blades likewise varies, making it necessary to alter the angle along the blades, so that the section of the blade, at any point, acts at the proper angle to the resultant. This condition is what makes it necessary to spiral the blades.

Bearing in mind all that we have said thus far, we now continue, at the request of many of our readers, actually to design a propeller for a gasoline model.

The designing of a gas model prop admittedly is not an easy task. It incorporates exactly the same procedure as used in the designing of propellers for real aircraft. Of course, the model builder is not expected to consider all the designing factors, as this would demand a much wider knowledge than merely the theory of the propeller.

Our main purpose is to give a quick method by which the task may be accomplished.

In our procedure of designing a propeller it becomes necessary to make certain assumptions. These assumptions, as shown by tests, have, however, been found accurate.

The first step is to determine the prop's diameter. To do this we must select the condition at which we want the prop to be of maximum efficiency. In some cases the builder would want the propeller to be efficient at maximum horse power, while in other cases the builder may desire the propeller to be efficient at 75% throttle.

In our case, we will strive for efficiency at full horse power. We

CONDITIONS:
 HORSE POWER... 2 (1/5)
 REV. PER. MIN. ... 4000
 VELOCITY... 25

$$D = \sqrt[4]{\left(\frac{90,000}{R.P.M.}\right)^2 \times \left(\frac{H.P.}{V}\right)}$$

$$D = \sqrt[4]{\left(\frac{90,000}{4,000}\right)^2 \times \left(\frac{2}{25}\right)}$$

$$D = 1.415' = 17''$$

FIG. 1

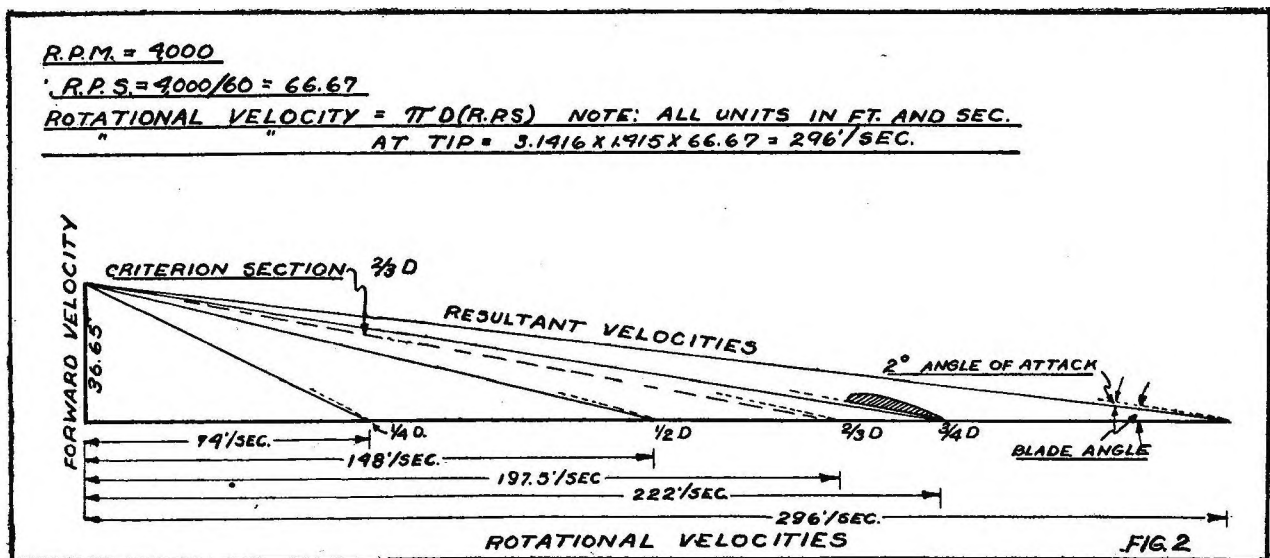

If you want your gas job to show real performance, your propeller must be correctly designed and carefully carved. Our Model Lab has just turned out such a prop, and this article gives you full instructions for doing the same.

* * *

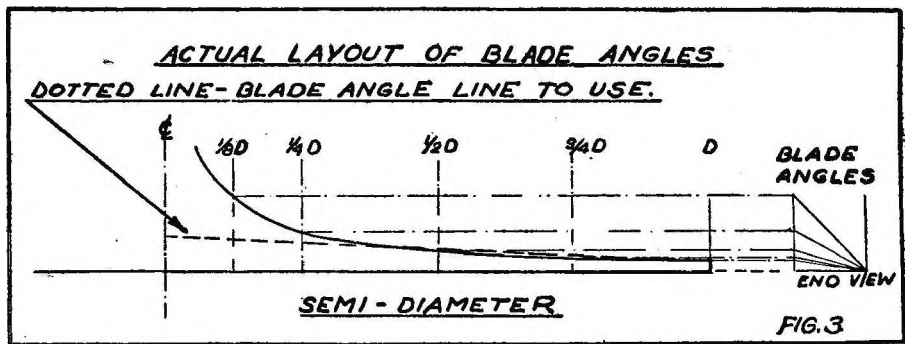

now select a motor—let us say a power plant capable of delivering 1/5 h.p. at 4000 revolutions per minute.

The diameter is then determined by formula. This formula (Fig. 1) has been developed through tests and has been found satisfactory for the computations on large aircraft propellers. It will be noticed that the formula includes the velocity of the airplane; hence it will be necessary to assume, as close as possible, the velocity at which the model will fly.

This assumption is left entirely to the builder. Those of us who have designed gas models will be able to determine this velocity with a certain degree of accuracy; however we will assume the velocity of our model to be 25 m.p.h., for a check among gas model builders shows that the average gas job travels at such a speed. Knowing all our values, we then substitute them in our formula and solve. Under the conditions we have assumed, the propeller diameter is 1.415 feet or 17 inches. (See Fig. 1).

ONCE we have determined our diameter our next step is to compute the rotational velocity, as is shown in Figure 2. All velocities must be changed into feet per second. To change miles-per-hour to feet-per-second, we multiply our m.p.h. by 1.467, thus our forward velocity becomes 36.65 feet per second.

We now compute our rotational velocity as follows (Fig. 2): The r.p.m. is 4000, hence the propeller makes 66.6 revolutions per second. The rotational velocity at the tip would then be equal to the circumference multiplied by the revolutions per second. This, as shown in Figure 2, is equal to 296 feet per second—which represents the number of feet the tip of the propeller has covered in one second.

With a ruler and a convenient scale we now lay off the forward and rotational velocity at right angles to each other, as shown in Figure 3. Connecting the ends of the lines, we then complete a triangle, the third side of which is the resultant velocity.

(In our last article we discussed this resultant veloc-

ity, but for the benefit of those who may have missed it we will briefly mention its significance again. The propeller, as we can see, is under the influence of the two velocities, rotational and forward. As we are all aware, the propeller consists of a series of airfoil sections which are influenced by the two velocities. Now when we have two velocities acting in different directions there will always be a resultant which acts as the two combined. In our case the resultant is the diagonal of a completed parallelogram from our two known velocities. With reference to this resultant, we locate our blade angle two degrees above the resultant. This two-degree measure represents the angle of incidence of the airfoil).

Thus far we have determined the forward velocity and the maximum rotational velocity (tip velocity). As we are all aware, the rotational velocity along the blade varies so that our angles of the resultant also vary. We now locate a number of points along the blade and determine their rotational velocity just as we have the tip velocity (Fig. 3). Adding on two degrees to each resultant angle, we will then have determined the blade angle at the respective points. In our case we will take the following points: $\frac{3}{4}$, $\frac{2}{3}$, $\frac{1}{2}$, and $\frac{1}{4}$ of the diameter. The rotational velocity at these various points would be in the same ratio as the points along the blades, hence the rotational velocity at $\frac{1}{2}$ the diameter would be half the tip velocity, or 148 feet per second, as shown in Figure 3.

Once we have located the angle of the blade at the various points along the diameter we are all set to lay out our propeller. But before we are able to do this it is necessary to determine the size of the propeller block from which we wish to carve the prop. Actually, it is only necessary to consider the width, as the builder will find that the depth depends upon the position of the blade angles.

It is far above our present knowledge of propellers to attempt to determine the width by mathematical computations, for such a method, in itself, is an intricate problem in the designing of large aircraft propellers.

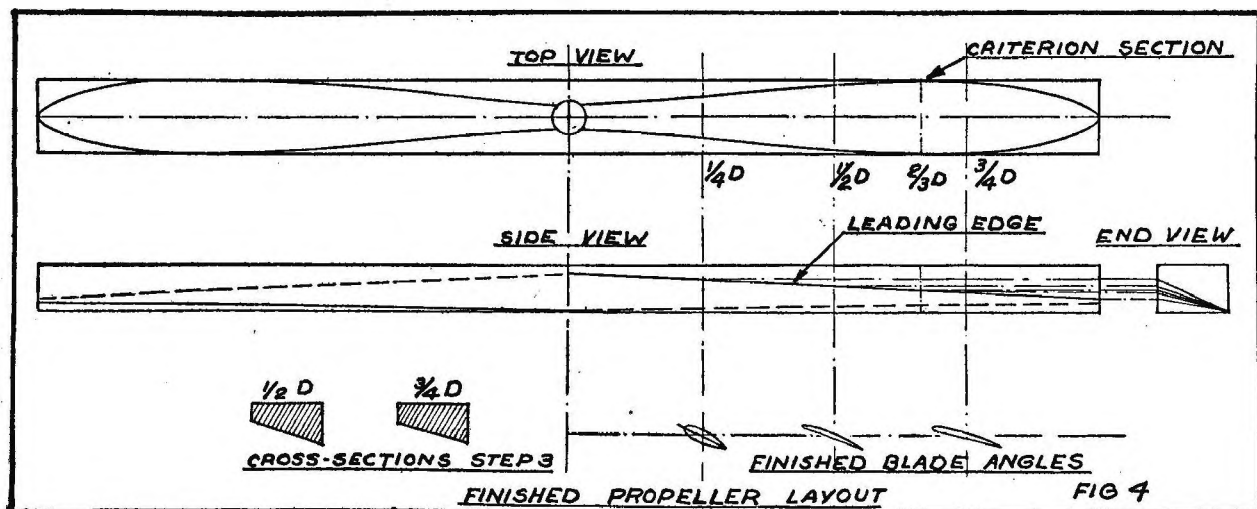

It therefore becomes necessary for us to *assume* a logical width. A check among various model propellers has shown the average width to be about 1/15 the size of the diameter. This makes our width 1.3 inches. Since this is purely an arbitrary value, the designer at his own discretion may use any other value which he believes will satisfy his conditions. But remember that the greater the width, the greater the resistance of each blade and hence the less efficient the propeller will be. On the other hand, a blade which is too narrow will likewise decrease the efficiency in that a great deal of the forward thrust will be lost.

With the two dimensions of our block determined (diameter 17 inches and width 1.3 inches) we now lay out the prop as follows:

STEP 1

FIRST lay out the blade angles at the various stations. Draw a line, as shown in Figure 3, representing the prop's diameter. Locate the center of the diameter and draw a center line.

Opposite to this line and on the same plane, draw a line representing the width. At each end of the two lines draw a perpendicular. This, as can be seen, represents a side view of the propeller and a projected end view. Since we do not as yet know the depth of the block our perpendiculars can extend to any distance (Fig. 3). Using the lower right hand side of the end view base line, we generate the various angles shown in Figure 2. These lines represent the change of the blade angle along the diameter.

We now locate the corresponding stations of these angles along the semi-diameter. Here we only work with half the diameter or the radius, such that the 1/2 diameter station is located at half the radius, and the 2/3 diameter station at 2/3 the radius. This is clearly shown in Figure 3. Now with a tee square, or other similar device, project the angles over to their corresponding station.

We have thus far located the position of the blade angles as looking from the side. With a French curve, or by free

hand, connect these points as shown in Figure 3. You will notice that you have obtained a curve which starts out from the tip with a rather small slope, and as it approaches the center of the propeller it increases rapidly. This is obvious, since each blade angle going from the tip toward the center is increasing toward a 90-degree angle. Of course, it would be impossible to build a propeller with the proper angles at the lower portion of the blade, as this would necessitate the curving of the blade, which would be impractical.

If you ever observe a propeller blade you will notice that it does have a slight curve. To overcome this dilemma, we follow through the points until they start to increase rapidly. This occurs about 1/4 of the radius from the hub. At this point we arbitrarily extend the curve until it intersects the center line of the propeller. In our case the points are almost in a straight line so that we can assume it as such. The dotted line (Fig. 3) is our blade angle line. The depth of the block is the height

(Continued on page 58)

From the Model Builder's Workbench



TIPS ON FINISHES

FOR solid scale models a lacquer finish cannot be surpassed. Lacquer is quick-drying and gives a glossy hard finish. It is obtainable in bright, true colors; and can be applied with a spray or a soft brush. It adheres well to any metal that is not greasy and to properly-primed wood. Even though it is expensive, it is the answer to the model-maker's prayer.

There are some properties which lacquer possesses, however, which are not so good. It will not adhere well to undoped balsa, and requires two coats or more before it will "stand out" and not soak into the wood. It is not advisable for use on flying models, for it adds too much weight. A flying model weighing an ounce and a half unpainted will often take on another ounce when decorated up with lacquer. This is generally fatal to flying performance. Lacquer, when applied to doped tissue wing-surfaces, plays havoc with them. The fabric never quite tightens up properly afterward.

But all the objectionable qualities of lacquer can be overcome easily. To get a good lacquer job on solid balsa parts, dope them with full-strength wing dope and allow to dry over night. Sand the "whiskers" off with finishing paper, and apply a coat of white shellac. After sanding again lightly, apply a coat of lacquer. White shellac is cheap, and primes the wood so that one coat of lacquer covers and flows out smoothly. Neither dope nor shellac adds any weight, and both are cheap compared with lacquer.

Shellac is a vegetable gum dissolved in alcohol, and alcohol is of the same chemical family as the amyl acetate used for lacquer solvent. Consequently,

shellac will dissolve lacquer if used over it. Strangely enough, however, lacquer does not take shellac into solution. There is a chemical reason for this, but the model maker is interested primarily in results, not chemistry. Since wing dope and lacquer are of the same chemical substance, shellac will dissolve wing dope as readily as it will dissolve lacquer, so shellac cannot be used on doped tissue surfaces.

For flying models from which one wants real performance, it is best to pass up the lacquer altogether, except on solid balsa parts, which should be primed as described in the third paragraph. For coloring doped tissue surfaces, an excellent semi-gloss, no-weight finish can be made of ground colors (which can be bought at any paint store for about five cents a pound) mixed in a liquid composed of one part spar varnish, one part white Japan drier, and one part turpentine—all in-

expensive supplies purchasable at the paint store.

The ground colors are obtainable in a wide range of shades, but only a few are needed, as they mix and blend to form almost any color. A half pound each of Chrome Yellow medium, Chrome Green medium, Yellow Ochre, Lamp-black, Delft Blue, Cobalt Blue, Haemite Red, and Mineral Orange, with a half pint each of varnish, Japan drier, and turpentine, will last even the most prolific model builder many months. And the whole cost will not exceed that of a few small cans of lacquer.

—JOSEPH F. MORRIS.

VARIOUS MODEL HINTS

WHILE building a replica of the popular Sikorsky S-42 for a recent contest, I experienced difficulty with the fuselage. As the body was hollow (to allow for the installation of an electric flashlight bulb) it was made in two sections, the top and bottom, or hull. After cementing together, I found that the portholes were uneven and looked rather unattractive for a competing model. Finally I found the answer to the problem in the use of ordinary soda straws.

For a sixteen inch span, drill the required number of holes in each side of the fuselage, 3/16" in diameter. Then, after placing some cement around the inside of each hole, insert the end of the straw in the cavity to the extent of about 1/8", and using a razor blade, cut off the long protruding part of the straw. Repeat this on both sides of the cabin, finishing one porthole at a time. When the cement is thoroughly dry in all places, the exterior of the fuselage may be finished, being careful not to

(Continued on page 79)

Attention, Model Builders!

FLYING ACES wants plans and directions for building flying scale models of the latest modern planes. In order to be printed in this magazine, drawings must be done in India ink, and must fit a 7 x 10-inch page. Plans should not exceed six pages. Photographs of completed models must accompany plans. Send in your work, model builders, and get it printed! Payment is made for accepted plans.

Something New!

A Cardboard Cut-Out Model

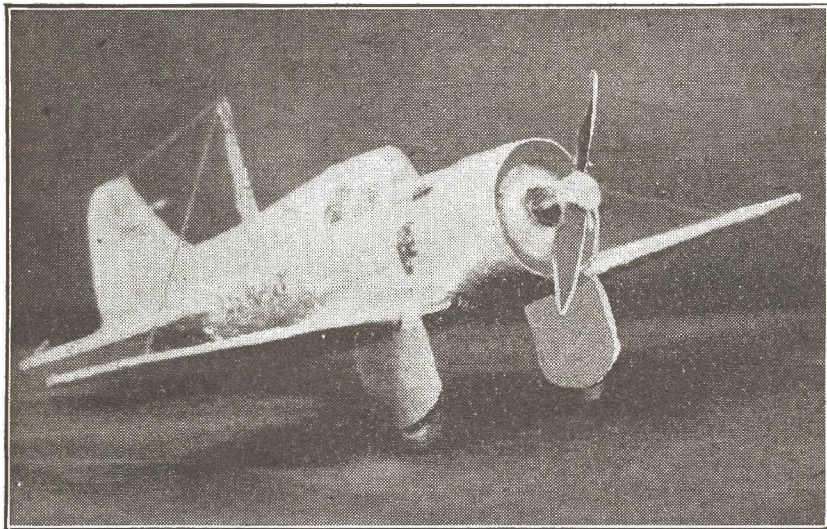

Above, you see Herb Lozier's original Navy Northrop. It's hard to believe that such a snappy model was turned out with shears and cardboard, but it was. And you, too, will learn how to do it in the accompanying article.

By Herbert Lozier

YOU all remember Frank Hawk's red-starred Northrop and the many spectacular flights he made with it. Lincoln Ellsworth took a similar job with him on his polar exploration, and many other Northrops have built up glorious records for themselves.

It seemed only natural that the people who make these fine planes should bid for a Naval contract. Therefore, when the new Northrop XFT-1, appeared, experts were sure that it could hold its own with the best of them. Its speed is still a secret, but it is estimated to be well over 250 m.p.h.! It certainly could pass the older planes without much effort!

The plane, a low-wing fighter, is powered with a twin-row Wright engine of 700 h.p. It is the last word in fighting ships, being equipped with radio and wing flaps. The control surfaces are not balanced, but the elevators and rudder are counter-weighted to ease their action. The cockpit is completely enclosed in a sliding panel of glass. Its armament consists of two machine guns synchronized to fire through the propeller. The wheels are housed in pants, much the same as on other Northrops. In appearance, the plane is graceful and racy. For that reason, and because of its wonderful performance, it was selected as the prototype for this model.

And here's the special feature—our model is built by cutting out cardboard sections and assembling them! The model is simple and strong. It will not sag or twist. A beautiful plane when completed, it is covered with silver-foil from cigarette packages.

There is one thing you must keep in mind while building the plane; remember, never cut on the dotted lines or on the lines marked "X" (see Plate 2).

The plane is built of the cardboard you get in your shirts when they come back from the laundry. A few matches and some glue will be all you need to complete the construction. Don't use corrugated cardboard, for it is too heavy. For the original ship, I used a semi-stiff cardboard, because its flexible qualities adapt it to this model. Remem-

Have you got some cardboard—the kind that comes with laundered shirts? And have you matches, thread, and cellophane and silver-foil from a cigarette package? Sure, all of you have materials like that on tap—and that's all you'll need to make this nifty Northrop XFT-1 model! If you can wield a pair of scissors and apply a little glue, this neat Navy fighter will be yours in short order.

★ ★ ★

ber, too, that you must always fold the cardboard *with the grain*, otherwise it will crack, producing a messy effect.

I suggest that you first read the following instructions and study the layouts thoroughly, for this is a new type of construction.

Incidentally, I covered my plane with silver-foil, rather than paint, because the foil makes the fillets and produces a shiny effect like the original metal of the big ship.

All plans are drawn full size. Before you do anything else, take the template plan (Plate 2) and cut out each part separately. Then glue each pattern firmly on your cardboard. I repeat, make sure that each piece that is to be bent *runs with the grain*.

Every part is marked with a letter, so you will have no difficulty in recognizing it. Remember that the parts cut out according to the templates must be trimmed down to the sizes given on the three-view plans. The templates are drawn slightly larger for safety's sake. Another things, while the glued parts dry hold them together with pins. Be sure to remove the pins when the joints are strong enough.

THE BODY OF THE MODEL

WE shall begin with the fuselage, which consists of parts (A & B) and formers (F & P). First, put plenty of glue on the forward part of the fuselage, just in front of the cockpit. Then spread some glue around the edge of the former marked "F", and bend the fuselage around it. "F" goes directly to the front of the body; it is the back-bone of the model, so be sure that it is glued securely.

The next step is to glue the bottom of the fuselage. This is the most difficult part of the entire construction, for if you do not take care that there are no bumps or twists, the model will be set out of line and will warp. Put plenty of glue on the open edges of the bottom and slowly press them together until the two sides meet. Then set it aside to dry.

When the bottom of the fuselage is thoroughly dry, take former "P," and, spreading some glue around its edge, place it in position in the cockpit. Then glue the upper back of the body in the same manner as you did the bottom. Part "I" should be glued

(Continued on page 95)

FULL SIZE PLANS—
for this striking cut-out model appear
on the following two pages.

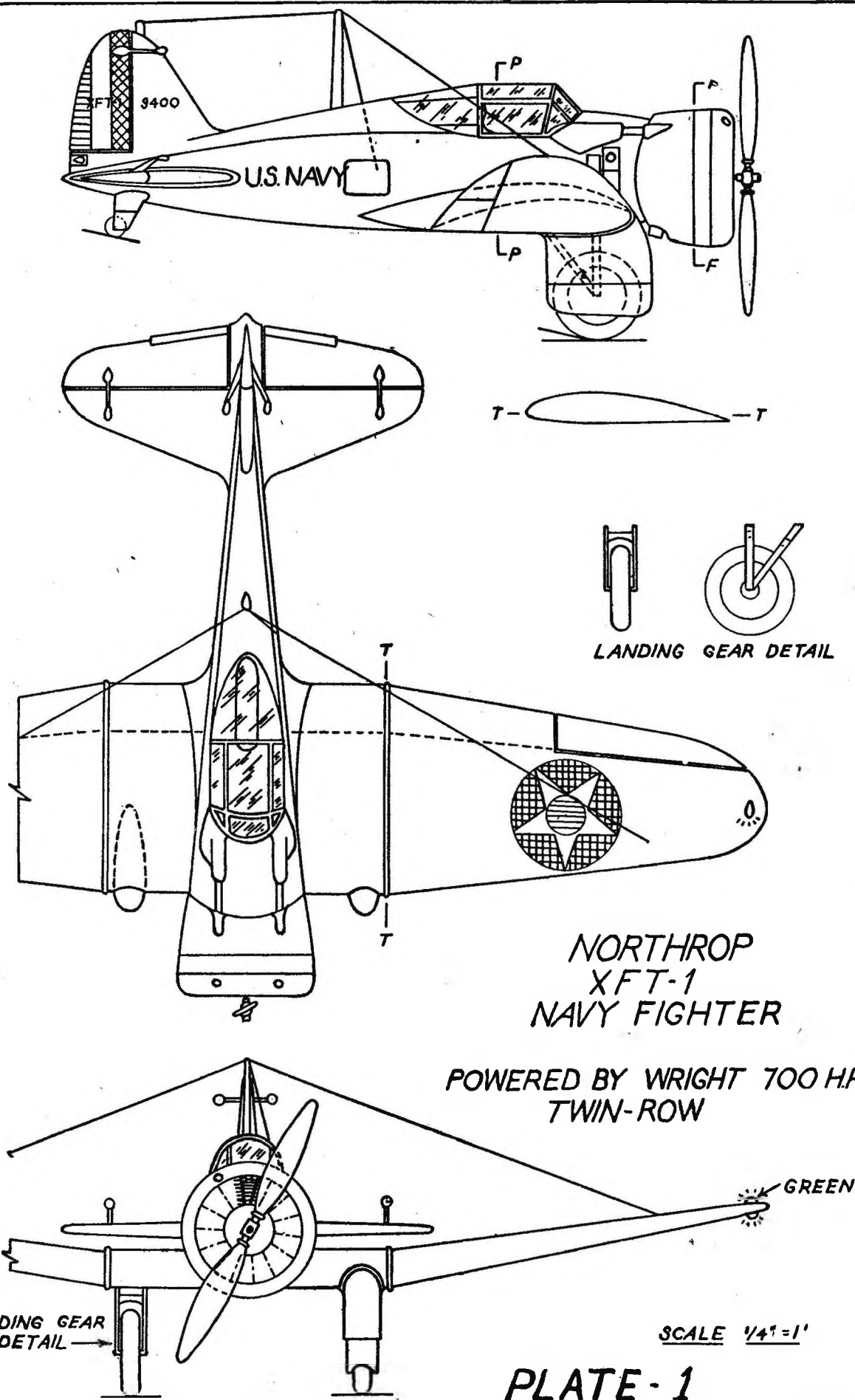

SOMETHING NEW! A CARDBOARD CUT-OUT MODEL—Plate 2

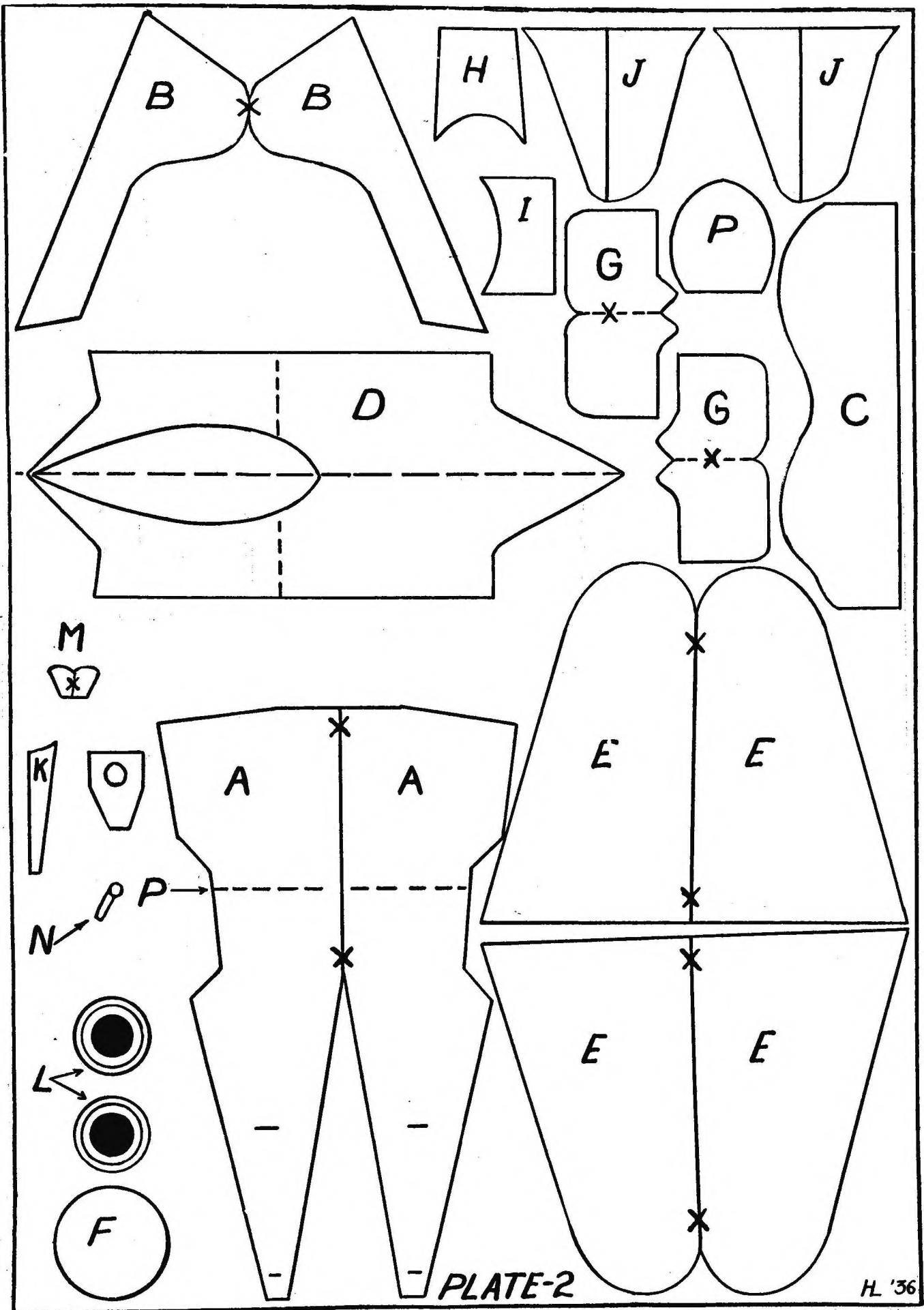

War-Model Fans—Build a Scale

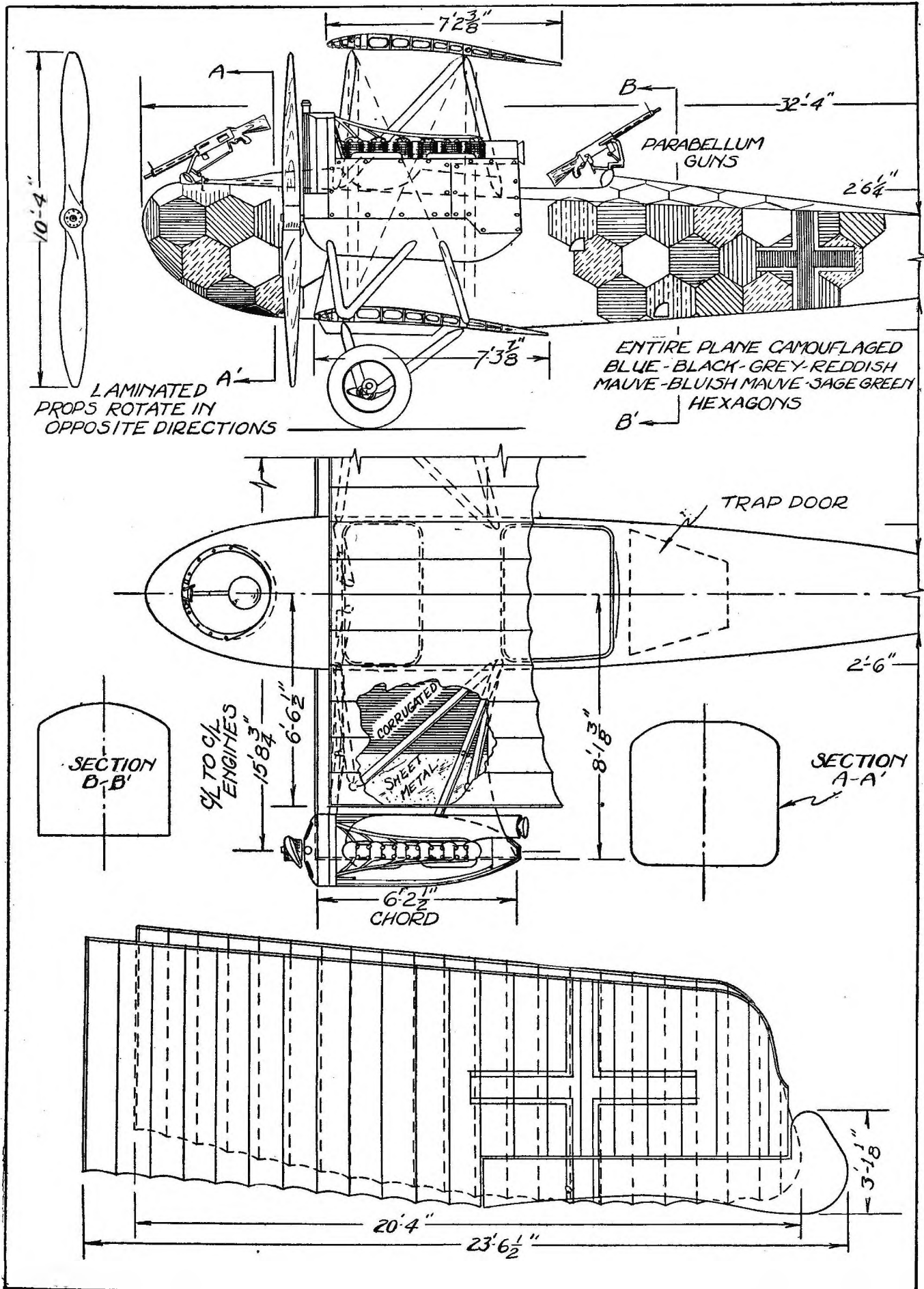

Replica of the A. E. G. Bomber

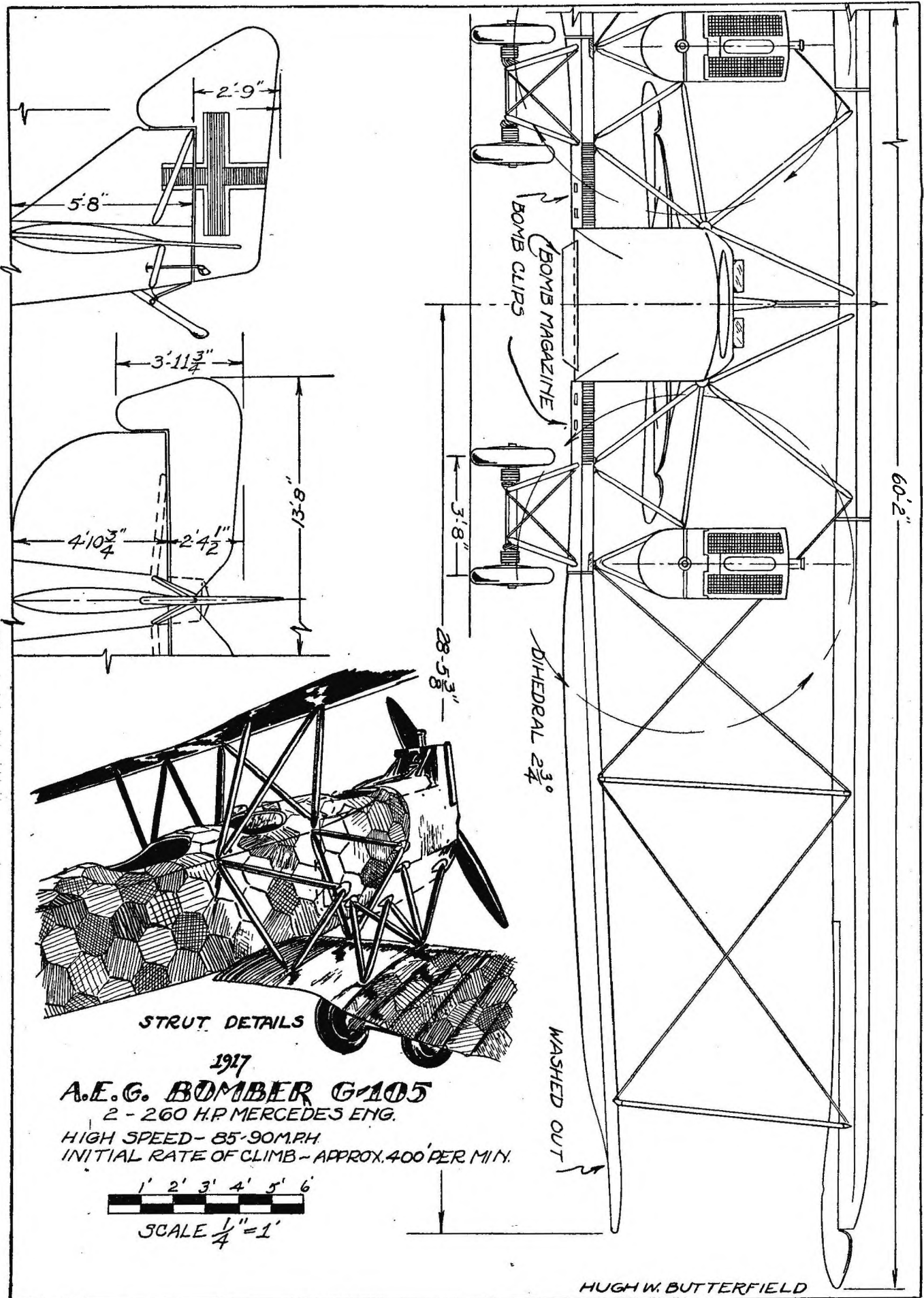

Modern Planes Album

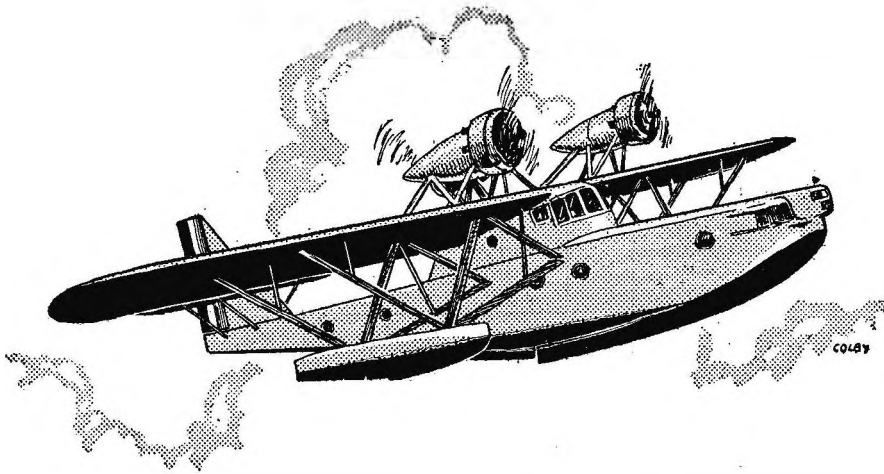

FRENCH LOIRE 70

THE FRENCH LOIRE 70

FRANCE'S flying boat situation is a distinct problem. Here we find that coastal defense—considering the geographical arrangement of the country—demands that flying boats can quickly be moved from one coastline to another.

Thus, a flight of flying boats stationed at Marseilles and suddenly required at Le Havre or Calais, would

be required to do an overland flight of at least 400 miles. If the boats cut across to Bordeaux, went along the Garonne to the Bay of Biscay, then turned up the west coast, they would be flying about 650 miles.

To protect French colonies on the other side of the Mediterranean, the sea pilots would face a flight of at least 450 miles.

France, then, requires flying boats

with a reasonable range of action that can take over duties either in the foggy English Channel or over the semi-tropic heat of North Africa. In addition, they must carry a wide range of military equipment.

The Loire 70 is a typical active service boat suitable for this work. It is a three-engine monoplane flying boat powered with 550 Gnome-Rhone 9-K engines which give it a top speed of 135 m.p.h. It has a range of 1,180 miles and a ceiling of 13,940 ft.

It carries a normal crew of six. In the nose there is a bomber-gunner's position. Aft of this is the compartment for the commanding officer. The control pit is behind this compartment and set high under the leading edge of the wing. There is a special compartment for the wireless operator and sleeping quarters for the crew under the rear motor. The bombs are carried outside on the wing-bracing struts.

From a careful study of the Loire line, this ship appears to be available with several types of cabin, one showing a variation in the construction of the commanding officer's quarters. There are three gun turrets with several arrangements of guns and mountings.

THE ITALIAN CANT Z.501

IN this single-engined light bombing and reconnaissance flying boat, we get a typical example of the type of machine that seems to fit the Italian situation.

The Boot of Italy extends far out into the Mediterranean Sea, hence home defense duties are scattered over the Adriatic Sea, the Ionian Sea, and the Tyrrhenian Sea. High speed trips of anything up to 350 miles are requisite for an efficient defense.

The Cant Z.501 did a world's record of 3,100 miles last July by flying from Monfalcone, Italy, to Berbera, British Somaliland. The distance was covered in 25 hours. This indicates that under long range conditions she cruises at 124 m.p.h. According to her builders she will do a top speed of 161 and will cruise normally at 137. We do not know under what conditions her record was made or what military load she carried, but we do know that the machine is to be used by coastal defense stations. This would hardly require any such length of flight.

The Cant Z.501 is a single-engined flying boat powered with a 850 h.p. Isotta-Fraschini motor which is mounted in the center-section of the

high wing. The engine nacelle is swept back to a point a few inches beyond the trailing edge of the wing and here becomes a gun-turret. Another gunner's position is incorporated in the hull amidships, and still another up front in the bow.

The hull is semi-circular and has two steps. It has a shallow vee-bottom forward and changes to a concave shape at the first step. The internal structure is composed of ash and spruce. The bottom and sides below

the water line are covered with a double skin of varnished tulip wood with a layer of doped fabric in between.

Eight machine guns are carried, five in the front cockpits, two in the upper gun turret, and one in the rear turret. Where the bombs are carried has not been announced, but the bomber apparently has a reclining position in a special compartment behind the pilot.

Truly a great flying boat!

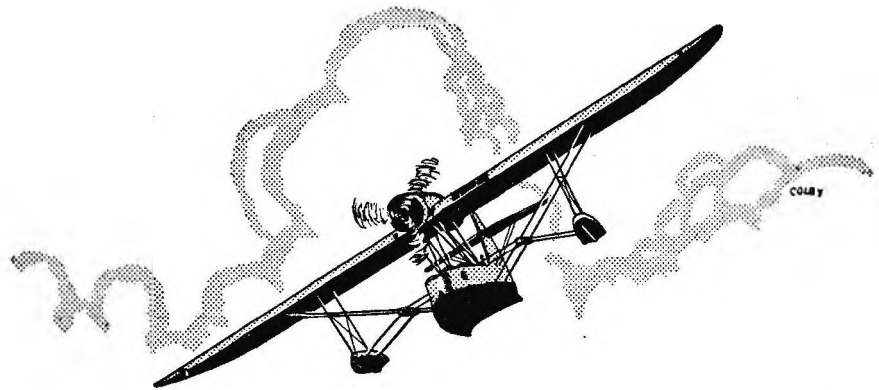

ITALIAN CANT Z-501

FOUR FIGHTING FLYING BOATS

Of all military types, the flying boat is probably the most misunderstood and least appreciated. Too many of our speed-mad critics have failed to consider the work required of these sea craft, most of which are designed for particular duties over specific geography. The accompanying study of representative ships of four different nations will help to clarify the many problems faced in the fighting flying boat field.

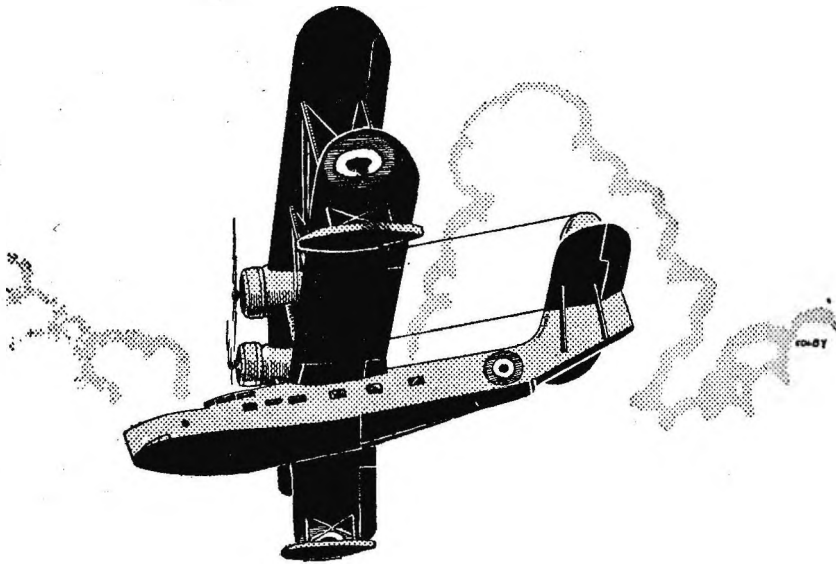

SUPERMARINE STRANRAER

THE SUPERMARINE STRANRAER

THE British problem for flying boats is quite a different matter, owing to England's peculiar situation with reference to Europe and its vital arteries of trade. In general, the British boats do not require great speed or great range because they have so many suitable naval bases

from which to operate that their prime requisite is to be equipped for the particular duties involved.

In the new Supermarine Stranraer, the Royal Air Force has a fast bi-plane boat powered with two Bristol Pegasus engines. In actual tests, this ship climbed with a full military load on one engine. The Supermarine firm, while not giving out the official fig-

ures, states that it is the fastest two-engine flying boat ever built in Britain. If so, she is very, very fast—speedier than the Short R 24/31, which has a top speed performance of 150 miles per hour.

The Stranraer is listed as a long-range reconnaissance flying boat for bombing. She carries 500 gallons of fuel which probably gives her a range of 1,000 sea miles.

In the bow is the bombing and gunnery station, and a hinged watertight door is provided low in the nose for bomb-sighting. The Lewis gun mounting slides aft and clear of general operations when not in use, as during mooring operations. All marine equipment is stowed in a compartment adjacent to the cockpit. Behind this is the pilot's side-by-side seating compartment which is fitted with dual controls. Immediately aft of the control pit and forward of the front spar frame is the accommodation for the navigator, while between the spar frames is the wireless and engineer's cabin. Aft of the wing is the 'midships gun position, and another gun is set well down the tail behind the rubber. A torpedo and a complete spare engine is carried, and the cabins are suitable for long cruises.

THE CONSOLIDATED XP3Y-1

THE primary American problem for flying boats is to tie up outlying points in the Pacific. The secondary problem is to be found in routine coastal patrols and reconnaissance work with the Fleet.

The business of maintaining close coöperation with the Pacific naval bases and certain possessions miles away from our West Coast is by far the most important job of the flying boat pilots.

In meeting these problems, America has gained the lead in the development of long range high-speed flying boats. (And you can be sure that in case of war in the Pacific, the long-range Pan American Clipper ships will automatically become part of the U. S. Navy flying boat squadrons.) Owing to the great width of the Pacific and the lack of suitable bases between the mainland and Hawaii, it is imperative that the Navy obtain ships boasting a wide range of action.

No other great power has quite

such a military problem to face.

The new Consolidated XP3Y-1 is a particular type in question. A high-wing monoplane with a normal boat hull, it is powered with two 800 h.p. Twin Wasps which, from all accounts, give it a cruising speed of about 110 m.p.h. This makes her at least one

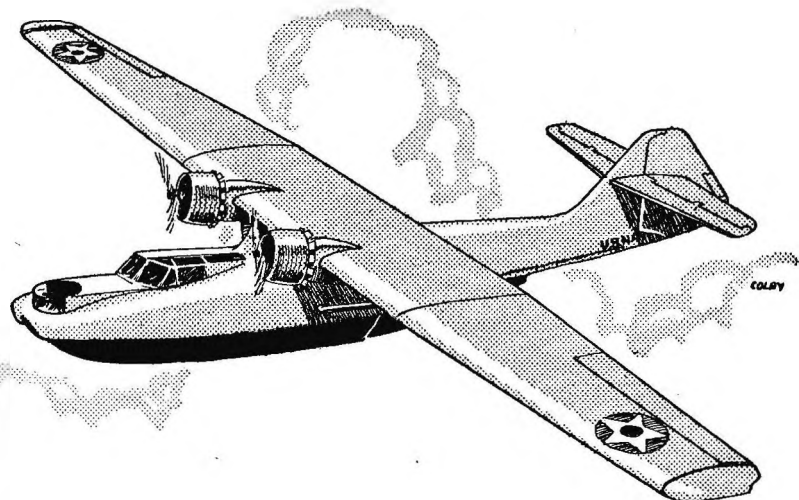

U.S. NAVY XP3Y-1

of the fastest (if not *the* fastest) two-engined flying boat in the world. In October one of these boats flew from Coco Solo, Canal Zone, to Alameda, Calif., a distance of approximately 3,400 miles in 34 hrs. and 25 min. This gives some indica-

(Continued on page 71)

Flying Aces Club News

This month, Buzzards, there's lots to tell you about the fine work done by F.A.C.'s during those disastrous Eastern floods, so settle down in your easy chairs and dig in with a will. And don't miss the latest dope on the F.A.C. Transport Contest. You'll find it over on the next page.

WITH the old F.A.C. transport "washed out" and "Robby," our robot pilot, down on the dumps with the rest of the tin cans, we're going back, temporarily at least, to dishing out the club news on one of the old style platters. And to tell the truth, your National Adjutant feels a bit lonesome with his old cronies—Joe, Arch, and Herb out of the picture. As a matter of fact, F.A.C.'s, that FLYING ACES Transport was beginning to seem real in my mind, and as I sit here at my typewriter I actually feel as though that transport *did* crack up. But the wall here is intact and so are Joe, Arch, and Herb. But our FLYING ACES Transport contest is no illusion, as you'll see on the next page. So don't forget to enter a ship. Perhaps yours will be named The New FLYING ACES Transport!

And now let's get started with the Club news—there's plenty of it this month, and it's mighty interesting, too.

Foremost in our minds is the splendid service rendered by the F.A.C. Radio Communications Corps and other units during the recent flood. The Dawn Patrol, Inc., Boston—with DPIHQ now officially the key station of the F.A.C. radio net—did a mighty fine job. During the height of the flood, the Patrol was on duty night and day with the U.S. Coast Guard. They had two cars, a trailer, surfboat, and all life-saving, first-aid and communication equipment with them. And note this—they were the only completely equipped unit in the

field of operations in their section, namely: Northampton, Hadley, Springfield, and Springfield, Mass.! Moreover, the Metropolitan Police Department of Massachusetts has just appointed the Patrol as a life saving unit in charge of patrolling a long section of the Charles River from May 1st to October 15th, 1936. And just as we go to press, Captain Lionel K. Berig, of the Patrol, advises that the Surf Life Saving Association of Australia has sent them a Charter of Affiliation—the Patrol being the first organization in this country to ever be so honored!

New York Squadron No. 13, at Troy, likewise covered themselves with glory! When the flood hit the city the civic officials called for volunteers to help build parapets and help those in the afflicted areas. The Squadron at once offered their services as well as that of their clubhouse—the headquarters being located on the high Sycaway Hill and consequently not affected by the rising waters. Consequently, the clubhouse was soon turned into a medical station, from which point supplies went forward by plane, boat, and runner. Half of the unit remained at headquarters while the other half, accompanied by their Athletic Director, Mr. Morrison, went out in boats to aid those marooned in their homes. Some went to bridges and helped build parapets to stem the swirling waters, while one of their number—Joe Shaak—went aloft in a relief plane to attempt to spot those in dire need. In concluding his report, Adjutant Walter Smith said, in part: ". . . and we did our best to uphold the high ideals of the F.A.C. in this emergency."

Walter, we'll say you did, and we're mighty proud of your entire unit!

Now let us skip out to Pennsylvania—to the little town of Clearfield, where the waters of the Susquehanna were mighty high a few weeks ago. Captain Theodore Cavanaugh, Pennsylvania Squadron No. 16, pointed out that all of their Flights, with one exception, carried on as usual during the flood. (The one that didn't was flooded out.)

Moreover, moving on from the flood news, Ted enclosed a clipping from a local paper concerning a former member of their unit—Jack Kline. It seems that Jack recently hooked up with the Consolidated Aircraft Corporation, San Diego, Calif., as a technician, and is well on the road towards making a name for himself. In addition to his commercial training, he has also passed all Army tests and today is a commissioned Second Lieutenant in the United States Air Corps Reserve, and it must be remembered that only the finest of pilots are capable of gaining such recognition in the Government flying forces. We take this opportunity not



Girls continue to land on the F.A.C. tarmac! Above is pretty Edith Marie Davis, of Cleveland, Ohio. Isn't that model a beauty, also! It's a Douglas O-38, and Edith built it all by herself. You can well be proud of that job, "Wings"! ("Wings" is what her friends call her).

only to congratulate Jack but also those members of the Clearfield F.A.C. unit who fostered Jack's interest in aviation, thereby helping him in his progress. And what is more—we understand Jack is still an ardent reader of good old FLYING ACES!

And here's some news from the Nation's Capital (by way of New Jersey): Postmaster General James A. Farley has joined the club in honorary capacity upon the invitation of Bob Schell, of Irvington, N. J. The Postmaster General wrote Bob a fine letter, part of which we quote:

" . . . As you know, I am very interested in the development of aviation in the United States. One of the very important branches of the postal service is the foreign and domestic air mail services. Remarkable progress is being made in these services, and, as Postmaster General, I am not only air-minded but I am keenly interested in the development of aviation and in the United States continuing to lead the aviation industry of the world."

Other honorary members to land on the F.A.C. tarmac this month are: U.S. Senator Chas. L. McNary, of Oregon, secured by Hugh T. Platt, Jr., of Portland—Law A. Astley, Florence, Mass., an aviator-mechanic, who served the U.S. in France during the World War, secured by Albert Packett, of Florence—and David Hauschild, Big Fork, Mont., signed up M. B. Freeburg, engaged in aeronautic pursuits at St. Paul, Minn. While on the subject of honorary members, F.A.C.'s, we wish that in the future you'd expend your efforts towards signing up persons who are either flyers or otherwise engaged



This fellow who looks like he just came out of the clouds is Commander Eddie Munzing, Dorchester, Mass., Squadron No. 2. Eddie and his friends are putting the F.A.C. on the map up there. Whenever there's an air picture at a local theatre, Eddie "cooks up" a lobby display with the Manager, involving models, flying equipment, copies of FLYING ACES, and the like.

in aviation circles. Of course, any person of note is welcome on our tarmac, but since the FLYING ACES Club is an aeronautic organization, let's confine our honorary members, so far as possible, to those actually engaged, or formerly engaged, in the work.

FROM across the seas comes interesting news in a letter from Bernard R. Thorne, Commander of the Consolidated F.A.C. British units, advising that recently a competition for flying models was run off for a trophy presented by the *Wing* magazine; and 90% of the entrants were constructed from kits advertised in FLYING ACES. Bernard says that the performances of all were good, proving that firms advertising in our official club magazine are one hundred per cent sound. Incidentally, we might add that Bernard has done much towards unifying and building up the F.A.C. in the British Isles. Those English readers who would like to join a unit will do well to contact him at British headquarters—29, Ruskin Ave., Feltham, Middlesex, England. Applicants will be put in touch with the nearest F.A.C. Flight or Squadron.

And speaking further of getting in touch with people—and this time getting a little closer to home—we might mention that George Laschinsky, 222 Lexington Ave., New York City, is desirous of securing additional members for his fine unit. George visited GHQ recently and from what he told us of his unit we're of the opinion that you fellows living in New York City and desirous of connecting up with a good outfit, will do well to contact him.

Getting back to radio, Colonel Robert A. McGinnis, in command of the Buffalo district, 1267 Seneca St., Buffalo, N. Y., would like to get in touch with an F.A.C. reader living in his vicinity who is operating an amateur radio

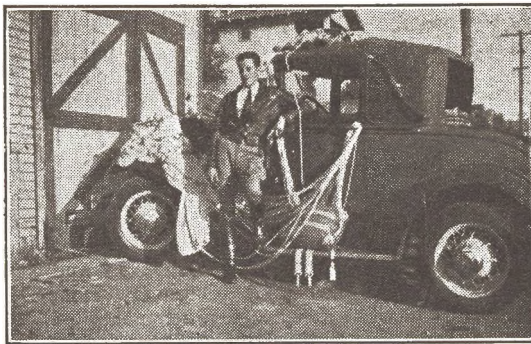

Recently, the Legion Aeronautica Mexicana, one of the best equipped F.A.C. units in the Far West, carried out an exhibition in the skies over Los Angeles. Above is one of their number—Captain Everardo (Eddie) Saucedo—with his parachute after a jump. From all appearances, Eddie didn't have any trouble missing the steeples and telegraph wires. He's ready to do it all over again.

station. To quote from Bob's letter: ". . . I send and receive but haven't the time or courage to go into it alone. Since we'd like to get into the F.A.C. radio chain, I will appreciate any assistance you may give me towards securing a good radio man." Certainly, somewhere in Buffalo right this minute there's a capable operator reading these very lines. Get in touch with Bob! Radio and aviation should go hand in hand, and you'll find the combination mighty interesting.

We know that many of you readers are not members of the F.A.C., and this paragraph is for your benefit. Don Heyman, Clinton, Ia., read FLYING ACES for a long while. One day he clipped out the membership coupon and joined the club. To date he has written us three letters, and here's a part of that third one:

". . . I have often wanted to belong to an aviation club that really takes an interest in you, especially and individually. I didn't find one until I joined the F.A.C. The letters you write make me feel as though you at GHQ are my old and best friends."

While we can lay no claim, Don, to

being your "old" friends, we can say with all sincerity, that we number ourselves amongst your "best" friends.

Out of the ranks of the F.A.C., one day, will come not only accomplished aviators, manufacturers, and the like, but writers as well. We're thinking right now of Miss Gene Schaffer, Oakland, Calif. A short while ago Gene sent us a copy of her high school paper—*The Daily U-N-I*, which carried a write-up of her interview with Admiral Richard E. Byrd. Now we note that a recent issue contains a fine article—this time the result of her interview with Amelia Earhart. Aside from becoming very enthusiastic over Amelia, Gene writes to the effect that she had a swell time when she got out of school for the interview!

And say—here's an honorary member we almost forgot! We refer to E. W. Davies, director of the *San Francisco Chronicle* Model Airplane Club. Mr. Davies is owner of the Davies Aircraft Company out there on the Coast, and his membership was secured by George Cull, of San Francisco. We're mighty glad to welcome Mr. Davies to our tarmac, since he, like FLYING ACES, is trying to build interest in aviation in the minds of the younger generation. And believe you me, George certainly knows how to get honorary members. How about the "recipe," Old Timer?

SPEAKING of far off places, we are just in receipt of a letter from Jim Tetteh, of Accra, on the Gold Coast, West Africa. Jim says he wouldn't miss a copy of FLYING ACES if he had to fight his way through several miles of jungle (and all we have to do is walk to the corner newsstand or take our copy from the Postman). Gee K. Tune, of Roxbury, Mass., writes that the instructor of their Chinese Flying Club—Lt. M. J. O'Neill—advises them to keep

Have You Entered The F.A.C. Transport Contest?



Racy lines feature Dick Brisbin's entry. He calls it the "Super-Star." Note the fan shaped tail, the long fin extending from the mid-portion of the body, and also the fanned engine cowls. The ship is painted gold with blue trim lines (the FLYING ACES colors) and an F.A.C. insignia is spotted on the fuselage.

Here's Dick Brisbin's Ship

Well, fellows, entries in the F.A.C. Transport Contest are now coming in at a good clip, so it won't be long before Joe, Arch, Herb, and Doug will have a new ship at their command.

In the first batch of prospective FLYING ACES Transports, the craft turned out by Dick Brisbin, of Omaha, Nebraska, caught our eye. The accompanying photo shows it, and you'll have to admit it's a neat job!

Incidentally, so many fans claim we're not giving 'em enough time to build a ship that we've decided to extend the contest after June 15th. We'll tell you the definite closing date in the August issue.

There's still time, then to enter; so here are the rules:

Your ship may be either a flying or solid model. The model must be of your own design—that is, it should not be a standard ship or a craft made from a kit. The model, moreover, must be painted in the F.A.C. blue and gold colors and must carry the letters, "F.A.C."

After you've got your model built, get out your camera, snap a picture of it, and send the photo to Doug Allen, FLYING ACES Headquarters, 67 West 44th St., New York City. The best photos received will be reprinted here in the Club News, and the very best one will bring a prize—a yearly subscription to FLYING ACES. The contest closes June 15th. A six-month subscription will be second prize, and a special prize will be on tap here for every builder who sends in a good photo entry. Of course, the first-prize ship will be christened The New FLYING ACES Transport.

abreast of the latest aviation news by reading FLYING ACES (orchids to you, Mr. O'Neill!) and that after he reads his copies he always sends them to a friend in China, a former member of their F.A.C. unit who recently went back to China to join the Government Flying Forces. Verily, FLYING ACES flies 'round and 'round and comes out in the most inaccessible places all over the globe!

Day by day we become more and more convinced that there are future "Amelia Earharts" in our midst. Take Francelia Snyder, Sharon Springs, N. Y., for instance: "Fran" (don't mind our calling you "Fran," do you?) is so wrapped up in aviation that recently

when the old mag reached her dealer a little late, the said dealer had to pacify her disappointment with a chocolate bar. A little later Fran called again (probably a half hour had elapsed) and still no FLYING ACES. When the copies *did* come in we understand the dealer hot-footed it to the Snyder home with a copy under his arm. No doubt the dealer was afraid that he'd have to fork over a box of bon bons if Fran had dashed in and still found no F.A.! Moreover, Fran tells us that she keeps a scrapbook of the most important pages of aviation books, but not so with FLYING ACES—she keeps the entire books!

Well, Buzzards, it looks as though your National Adjutant has written

more than enough "copy" for this issue, so GHQ will "sign off" now with "Happy Landings" to all. If you can find the time, won't you drop your old friend, Doug, a few lines as to which way you like the club news dished out—straight from the shoulder (as this is written) or dressed up with a little color—the F.A.C. Transport, Joe, Arch, robot pilots, etc.?—DOUG ALLEN.

Citations and Awards of the Flying Aces Club

The Distinguished Service Medal of the Flying Aces Club has been awarded
(Continued on page 86)

The New Airmail Pals

* * *

AS your friend, the Right Honorable Pal Distributor sits here at his typewriter, the beautiful, balmy weather of spring is zooming pleasantly just beyond the window sill—or doesn't weather zoom? Anyhow, summer is just about upon us, and the letters you scribblers are tossing our way are beginning to reflect that "knee deep in June" quality.

Spring certainly affects different people different ways! Reid Van Wormer, one of our pals in Guilderland Center, N. Y., writes in to say that he's got a lot of ideas from the Phineas stories, and he wants to know whether Joe Archibald ever heard of putting Limburger cheese on the exhaust pipe of a car. "Try it on your worst enemy some time," says Reid, "and spread it on thick."

Spring apparently has given Reid the practical joke bug. But speaking of bugs, we want to tell you about Thomas E. Murray, an A.P. up in New Haven, Conn. Tom has just bought himself a real bug—a Flying Flea! "I've put about 28 hrs. on it," he writes, "and I want to say that any young fellow who knows anything about motors should have one."

You said it, Tom! There's nothing like the light plane sport!

As for the general run of pal letters, we find that model building is still the most talked about hobby—and why shouldn't it be? There's certainly no better way to get a good aeronautical background, and model builders make great pals, too.

Do you remember our mentioning Chester Hovey, of Seattle, in our May issue? Chester wrote in looking for a pal who specializes, just as he does, on small models. Well, Chester is now pal-ed up with Robert Beaick, of Pointe Claire, Quebec, Canada. Bob wrote in specifically asking for Chester.

In the same way, we're going to hold out the letter we got this month from Jack Taylor, of Glendora, Miss., until the right pal writes in to get him. Jack's big hobby is coin collecting, and he's started a sword and pistol collection into the bargain. Since he lives on a big plantation, he ought to have a lot to tell about cotton raising down in Dixie.

And now listen, Buzzards: Your friend, the Right Honorable Pal Distributor, is still waiting for some of you to take time off and write to *him!* How about it? Of course, the R.H.P.D. has got several short greetings from you scribblers—but what he's looking for are real letters from you A.P.'s telling about some of the experi-

ences you're having in writing to your new-found pals. He wants to print some of these letters in this department. Come on, don't be bashful!

We'll tell you an interesting experience *we* just had. Ruth Rogers, of Grand Rapids, Mich., sent us a pal letter which was full of just one subject—her interest in guitar playing. Well, believe it or not, the very next letter we opened contained a picture of a fellow sporting a swell guitar! It was Fred G. Lewis, of Northampton, England, who has done radio work in London with his six-stringer. You're right! We pal-ed them up pronto!

There are plenty of other pals here that we'd like to talk about. There's Margie O'Donnell, of Elmira, N. Y., who wrote for a pal after finding that the R.H.P.D. got a swell one for her sister. There's also Alex Mills of Victoria, Australia, who has shot kangaroos from an auto going 60 miles per hour. Then there's George Bloom, Jr., of Charleston, W. Va., an expert fly caster who has a lot of fish stories on tap. And there's—

Phooey! We've gone and used up all our space. So we'll have to shut up shop 'til next month. Tra-la, all you pals!

—THE RIGHT HONORABLE PAL DISTRIBUTOR.

HOW TO GET AN AIRMAIL PAL

FIRST, write a letter just as if you were writing to your new pal—the kind of letter which tells your age, particular interests in aviation, your hobbies, et cetera. (If you wish, you may include a separate sheet of paper telling us, in a general way, what kind of a pal you seek). Next, send this letter to Airmail Pals, care FLYING ACES, 67 West 44th St., New York City. And be sure to enclose a stamped, self-addressed envelope.

Now, when your letter arrives, we select a Pal for you from our batch of letters—the sort of Airmail Pal your letter indicates you want—and we mail *his* letter to you in the stamped envelope you send us, and we mail *your* letter to him. Then you're all set! Of course, if you want additional Pals, just write us again.

REGARDING FOREIGN PEN PALS

IN case you do not reside in the United States, write a pen pal letter as above—but do not enclose a stamped, self-addressed envelope or send any money for stamps. Your pal letter will be forwarded to an American correspondent, following which you need only wait for his reply.

If you are an American who wants a foreign pal do not write a pen pal letter. Simply send us a stamped, self-addressed envelope with a note telling your age and stating that you wish a foreign correspondent. A foreign writer's letter will be returned to you in the envelope you send us—whereupon you may begin writing to him direct from your own home. The foreign airmail pals are cared for in this fashion because foreign stamps sent in from other countries cannot be used in the United States to forward letters to Canada or across the seas.

Unfortunately, our supply of foreign pals is limited. Those of you who seek foreign pals will be given American correspondents whenever the supply is exhausted. Please note also that we cannot supply you with foreign pals in non-English speaking countries where FLYING ACES is not distributed.

JOIN THE FLYING ACES CLUB

Honorary Members

President and Mrs. Franklin D. Roosevelt
 Vice Pres. John Nance Garner
 Casey Jones Rear-Admiral Byrd
 Wallace Beery Capt. Edward Rickenbacker
 Al Williams Colonel W. A. Bishop
 Col. Scaroni Major G. A. Vaughn, Jr.
 Major von Schleich Willy Coppens
 Lieut.-Col. Pissard General Balbo
 G. M. Bellanca Amelia Earhart Putnam
 Capt. Boris Sergievsky Frankie Thomas
 Colonel Roacos Turner Josef Veltjens
 Charles W. A. Scott Tom Campbell Black
 Richard C. DuPont Eric Kingsford-Smith
 Capt. A. W. Stevens Capt. Edwin C. Musick
 Capt. O. A. Anderson Clarence D. Chamberlin
 Mrs. Charles S. Baylies
 Lieut.-Col. Theodore Roosevelt

Official Charters

F.A.C. Flights and Squadrons are recognized only when they have been awarded Official Charters. These Charters are illustrated to depict the various steps of advancement in aviation, and the wording is in keeping with the high ideals and purposes of the Club. They are printed on a very fine grade of paper and the names of the Squadrons are hand-lettered. Charter applications must always be accompanied by a complete list of members with their addresses. For the Flight Charter send 25c, for the Squadron Charter 50c, to cover costs.

Volunteers for G-2

G-2, the Inner Circle of the F.A.C., is open to a restricted number of members who are qualified for Secret Service activities. Those who are chosen will have unusual opportunities to win the Club's Distinguished Service Medal. Those who are accepted will be given a secret number and identification card as well as the secret code. Assignments will be made by letter and code.

Save This Coupon for the
NEW CADET WINGS
 of the Flying Aces Club



COUPON
 No. 44

All members with Official Membership Cards are eligible for Cadet Wings. This coupon, with two others and 10c, entitles members to Cadet Wings. Do not send this coupon alone. Save it until you have three. Then send them in all together with a self-addressed envelope and 10c to cover cost of wrapping and mailing. Only one pair of Wings to a member. If you lose yours, send 25c for new ones.

Canadians send International Reply Coupon for 15c. British send one shilling in coin or International Reply Coupon for one shilling.

Do Your Full Share to Advance Aviation

No Dues—No Red Tape

How to Join and Form a Flight or a Squadron

To advance the cause of aviation, over 50,000 men and women, boys and girls, have banded together to form the FLYING ACES CLUB.

It's the easiest thing in the world to join. Just clip out the application blank at the right, fill in, and mail, along with a stamped, self-addressed envelope, and you will receive your official membership card by return mail. After that you can quickly advance to earn CADET WINGS, PILOT'S WINGS, and other honors.

To organize a squadron, you must have 18 members, including yourself, holding cards. To organize a flight, you must have six members, including yourself. Send names and addresses to headquarters. To cover costs of the official squadron charter a charge of 50 cents is made, and 25 cents for the flight charter.

Meetings and activities are conducted among the squadrons and flights according to the wishes of the members. GHQ has established no rulings in this respect, nor are there any dues or red tape whatsoever. The entire idea of the Club is a common meeting ground in an international organization for the lovers of aviation in its various phases.

Many fine friendships have been formed through the Club. Many youths have found an incentive to fly, and aviation's makers of history have lent their names and given their advice and best wishes to the F.A.C.—the ever-growing legion of eager, actively air-minded men and women, boys and girls.

The simple rules of the F.A.C. are clearly put on this page. Learn them and read the F.A.C. news in the magazine. And remember—when you write, always send a self-addressed stamped envelope, for the Club receives thousands of letters each week.

THE HIGHEST AWARDS

After the membership card and Cadet and Pilot's Wings, comes the Ace's Star, awarded for obtaining five new F.A.C. members, using the application to the right. The FLYING ACES CLUB DISTINGUISHED SERVICE MEDAL is awarded to members whose work on behalf of the club is "beyond and above the call of duty." The best way of putting yourself in line for this coveted medal is through the medium of efficient G-2 work, and of course honorary memberships of prominent flyers, or persons otherwise engaged in the various phases of aviation, will bear weight when members are being considered for the D.S.M.

Attention, F. A. C's!

This Beautiful Aviator's Identification Bracelet



Now 25c!

Because we wish to place the beautifully designed F.A.C. AVIATOR'S IDENTIFICATION BRACELET within the reach of all members of the club, decision has been reached to cut, temporarily, the price in half. Remember—this offer will be in effect for a short while only, and we suggest that you send your quarter immediately, since this is a real bargain. In sending coins be sure to wrap them securely.

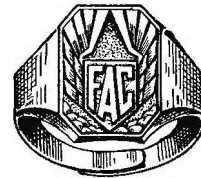

The
 Beautiful
 F. A. C.
 Ring

The official F.A.C. club ring is a beauty and should be worn by all members. It is self-adjustable, to insure a perfect fit. It is finished in antique silver. Sent post-paid anywhere in the U. S. and possessions for only 50c. (A STERLING SILVER ring, of similar design, may be had for \$1.00)

July Membership Coupon

I, the undersigned, hereby make application for membership in the Flying Aces Club. I agree to live up to its rules and regulations; to foster the growth and development of aviation; and cooperate with all other members in the work of spreading aviation information, building up confidence in flying for national defence and transportation. I will aim to build up the Club and its membership, and do my best to win the honors that the Flying Aces Club offers.

My name is
 Age
 Street
 City State

Mail this application, enclosing a self-addressed, stamped envelope. Canadians send International Reply Coupon worth 5c. British send a similar coupon worth sixpence.

Citations and Awards

Citations and awards, heretofore published on this page, will henceforth be found at the close of the Club News. Be sure to refer to those columns—YOUR name may be among the names to be found there.

F. A. C. Stationery and Official F. A. C. Pennants

Due to popular request, we have ordered a new supply of F.A.C. stationery and official F.A.C. (paper) pennants. The stationery is of high quality with the Flying Aces Club letterhead attractively hand-lettered, and the price is amazingly low—100 sheets, postpaid for 25c. The attractive pennants (with glue on the back) sell at the rate of 6 for 10c or 20 for 25c.

Save This Coupon for the
NEW PILOT'S WINGS
 of the Flying Aces Club

COUPON
 No. 41



All enrolled members who have won their Cadet Wings are eligible for Pilot's Wings. This coupon, with four others and 10c, entitles Cadets to Pilot's Wings. Do not send this coupon alone. Save it until you have five. Then send them all together with a self-addressed envelope and 10c to cover cost of wrapping and mailing. Only one pair of Wings to a member. If you lose yours, send 25c for new ones.

Canadians send International Reply Coupon for 15c. British send one shilling in coin or International Reply Coupon for one shilling.

FLYING ACES CLUB, 67 W. 44th St., New York

Flying Aces Model Laboratory

(Continued from page 46)

at which the blade angle line intersects the center line.

STEP 2

AFTER we have finally determined our blade angle line we then obtain the proper size balsa block and proceed to lay out the markings on the block. The shape of our propeller blank must be again assumed. This, however, is not a very hard task in that the shapes of all propeller blades are along the same lines. In the designing of a propeller it is assumed that one of our blade elements (sections of the blade) acts as the resultant of all the other blade elements combined. It is further assumed that this blade element (referred to as the criterion section) is located at about 2/3 the radius of the blade and is the widest of all the blade elements. In laying out the shape of our blade we first locate the criterion section (Fig. 4). Then with the aid of a French curve draw in a neat looking blade. Now in drawing the blade it is important that the section at the hub is not too narrow, as this will weaken the propeller tremendously. The section above the criterion section is rounded off to a neat shape.

STEP 3

OUR next step is to carve the prop. Here a great deal depends upon the carver, therefore we will only speak of the various stages involved. In Figure 4 is shown the layout before carving.

The blade angle is first carved in the following manner. Lay out on the side

of the block the blade angle line. (You will notice that the tip does not extend directly down to the base line.) With a straight edge, draw a line from the center of the propeller to a point slightly below the end of the blade angle line. This line is clearly shown in Figure 4.

With a sharp knife we then cut away all the excess balsa beneath the blade angles. After this, the cross section of the propeller block should appear as shown in Figure 4. The next step is to cut away all the excess balsa around the top view of the propeller.

Before we go any further it is very important that we make a definite marking on the center of the propeller, for if this is lost it's difficult to locate it again. A small hole will be sufficient, or if you wish a pin may be passed through the center.

Now finish your prop off in the following manner: Carve all the excess balsa away so that the blades now have a cross-sectional shape resembling that of an airfoil, or wing section. The portion of the blade directly adjacent to the hub need not resemble an airfoil section. It should be carved so as to give rigidity to the propeller. The cross-section at this point should resemble a bulky symmetrical section. It is rather hard, in words, to explain the method of obtaining the final shape of the propeller, therefore you should observe any type of wooden propeller and see for yourself how it should be finished off.

IT is worth a few lines to mention certain facts in the designing of any type of propeller. The hub is of extreme importance. Before deciding upon the shape of the propeller first find out

the size of the crankshaft of your motor. Your hub should then be designed so that after the shaft size is drilled there is sufficient wood left to resist any abnormal loads which might be applied. In shaping the blades it must also be remembered that a thin blade will break rather easily should the model nose over in landing.

On the other hand if the propeller is built of strong material, such as metal, there is a possibility that you may save the propeller but in doing so bend the propeller shaft—a rather costly accident.

In this article we have gone through the procedure of designing a propeller. The design of this propeller was based upon the assumption that our model travels at a velocity of 25 miles per hour. Because of this assumption, our diameter came out as 17 inches.

If we had assumed a higher speed, it can readily be seen from our diameter formula that our diameter would have been less. It is, of course, an intricate problem to determine the speed, for this necessitates the calculation of the airplane's resistance and available horse power curve. You gas model builders who wish to be able to do this are asked to write to this department.

In conclusion, if there are any questions concerning the designing of your gas model propeller, write in and we will be glad to help you.

GAS JOB FANS—PLEASE NOTE
Unfortunately, Phil Zecchitella's gas model article could not be completed in time for this issue. It will, however, appear in our next number.

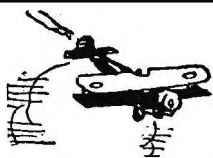

Headed For Your Tarmac

IN THE

NEXT GREAT NUMBER OF FLYING ACES

Fiction—"Buzz" Benson hurtles through a startling West Coast sky mystery.

"Phineas," believe it or not, finally gets sent — to Blois!

And other ace fiction chock full of air action.

Fact —Two-Seaters and Their Battle Tactics—another great David Martin special.

The Inside Story of an Aircraft Clinic—how the expert aero "doctors" keep our transports fit.

The Dramatic Story of Attack Plane Progress—a top-notch photo feature.

Model Building—Plans for the Curtiss Pulitzer Racer, the Douglas Sleeper, and others;

How to build a model Ranger V-770 SG engine; a feature on fuselage and wing construction; and a special detailed article on the leading gas motors.

IN AUGUST FLYING ACES

ON SALE JUNE 25th

Drome of the Bat Staffel

(Continued from page 8)

The man's eyes twitched back, but he was too late. With sledge-hammer force, Strange's fist landed on his jaw. His head snapped back, and he went down, spread-eagled. The guns slid from his limp hands.

Strange looked quickly at Jordan, then turned to Karol. She shrank back, put out her hand in a pleading gesture.

"Please, let me tell you—"

Strange opened the door to the hall. No one was coming. The drone of the cycle had kept the scuffle from being heard. He turned to the girl, his face like granite.

"You'd better hurry. You won't have but a minute."

"Strange, - are you mad?" Jordan burst out hoarsely. "She's a spy—a cold-blooded killer!"

Strange winced, but barred the way as Jordan lunged at Karol. She paused in the doorway, deathly pale.

"Philip!" she moaned. "You've got to know—"

Outside, the motorcycle engine gave two thunderous blasts. Karol cried out something he could not hear, then whirled and ran.

"STOP her!" raged Jordan. He tried to shove Strange aside, but the G-2 ace grimly blocked the door.

"I'm sorry, colonel," he said stonily. "I know it's treason—but I can't see her shot as a spy."

"But she was back of this whole murderous business!" fumed the older man. "I heard you accuse her of it."

"I didn't believe it, even then. I was only trying to get a hint of her purpose in attempting to capture me."

The G-2 colonel made an angry gesture. "That's plain enough! Either the reward for you, or her damned Hun patriotism. I told you before that her German blood would prove stronger than any love she might have for you."

The sputter of the motorcycle again became a deafening roar, then quickly changed as the machine raced away. Jordan swore furiously. Before Strange could stop him, he turned and charged through the next office, shouting for the guard detail. With a heavy heart, Strange followed to the bull-pen. Jordan was bawling orders at the first group of men who had responded to his yell.

"Get after that motorcycle! Arrest the nurse and the driver!"

The men dashed out, and in a moment the whole field was in an uproar. Strange waited until the bull-pen was empty, then slowly took his .45 from its holster. Jordan glared at him as he laid it on a desk.

"What's the idea of that?" he snorted.

"I'm ready to be placed under arrest," Strange said quietly.

"Humph!" grunted Jordan. "What you need is to have your head examined."

Strange flushed. The G-2 chief curtly pointed to a thin trickle of blood on his wrist.

"Better have that needle yanked out of your arm—unless you want to keep it as a souvenir."

He turned to the door, summoned a squad, and stalked back to the room where the unconscious spies had been left. Strange went out to the first-aid room. He found two of the Army doctors examining O'Rourke's body.

"Could you tell anything about that invisible fire?" he asked, as one of the surgeons was extracting the needle tip from his forearm.

The surgeon shook his head.

"Only that the effect is worse than an ordinary first-degree burn. The post-mortem may show something, though."

Ten minutes later, when Strange returned to the office, he saw a crowd around a motorcycle near the door. Something cold touched his heart, then he heard a disgusted voice.

"Naw, they got away clean. We found it down the road."

Strange went into the building. The lights were now turned on, and the place was filled with officers. He pushed through the crowded bull-pen and made his way to the end of the hall. Jordan was alone in the office. He looked up sourly.

"Did you learn anything from those two men?" Strange asked in a dull voice.

"They're being worked on," growled Jordan, but they're probably only minor cogs in the machine." He held out a small object. "Does this remind you of anything?"

Strange bent over. It was a miniature emblem in black and white enamel, composed of a tiny skull with webbed black wings extending out on each side.

"You're thinking of Karl von Zenden?" he said. It was more a statement than a question.

"Right," snapped Jordan. "It's the same symbol, only smaller, that he used to leave in those murder cases when we first came across him. In my opinion, this pin was used to identify a member of a special spy-group. It means that *Fraulein Doktor* and the 'Man of a Thousand Faces' are working together on this thing."

Strange's face shadowed. The famous Prussian impersonator was well known as a cold-blooded murderer. Once before, Karol had been forced by German Intelligence to work with him on a scheme, but he had hoped that that association was ended.

"I'm going to warn all G-2 stations," Jordan said shortly. "Tomorrow, I'll take full charge of the affair. Meantime, I hope you come to your senses and realize—"

He stopped as the extension phone rang. He answered, listened for a moment, then swore fiercely.

"Get word to General Thorne!" he rasped. "I'll be there in fifteen minutes."

"What is it?" Strange asked anxiously as Jordan stood up.

"The 87th Pursuit was wiped out half an hour ago!" Jordan said harshly. "It was the same thing which struck here.

And thanks to you, we've lost our main chance to get the truth in a hurry."

"She wouldn't have talked," Strange said in a weary voice. He picked up his helmet and gloves, turned away.

"Where are you going?" demanded Jordan.

Strange's face was devoid of expression.

"I'm going to Germany. I'll make up for what I've done—or I won't be back."

CHAPTER III

DEATH FROM THE DARK

THE altimeter hand stood at the two thousand mark. Strange looked somberly at the other instruments as the Spad roared on through the night. The clock face, its radiolite dial shining from the shadows of the cockpit, showed the hour to be almost eleven.

The G-2 ace made a quick estimate. He was approximately ten miles from the special Intelligence station at the edge of the Bois d'Abbecourt. A shift to Boche uniform, a change from the Spad to a captured Albatross, and he would be on his way across the lines.

He stared into the darkness, lost in bitter thoughts. This was the fourth time he had encountered Karol in the tangled trails of espionage. Each time he had prayed that they would not meet again until the war was over. But tonight . . .

His lean face tightened. Could Jordan possibly have been right? Could she, under some tremendous pressure, have agreed to deliver him to Germany? He shook his head. It was impossible—he knew her too well—there must be some other explanation . . . And yet, the hypo needle—the spies waiting to carry him out, probably covered so that he would be thought one of the dead . . .

If only he could have read her thoughts. In those precious months before the war it had happened more than once. But tonight he had been stunned, his mental processes dazed.

Karol von Marlow . . . *Fraulein Doktor*. How Fate must have laughed when it brought Karol and him together in those days back in old Mecklenburg. A deep sadness swept over him. An eternity seemed to have passed since then. But he had never forgotten that Mecklenburg garden in June, and the lovely, dark-eyed girl who had promised to wait . . .

Abruptly, a feeling of danger crashed through his sad thoughts. He sat up tautly, staring about him. The partially masked exhaust flames from the Hispano stacks were the only break in the blackness. But he had a swiftly increasing sensation of imminent peril. With a jerk at the stick, he sent the Spad corkscrewing up into a chandelle. The clammy darkness of a cloud closed about him. He leveled out as he felt the mist on his face. Pulling the throttle back, he let the ship settle flatly.

He peered around into the night as

the Spad dropped out of the cloud, but the blackness was like a blindfold. He looked down quickly. Nothing broke the darkness below. Even if some Boche were trying to stalk him, there was nothing to silhouette the Spad. The other man would be just as helpless in the dark.

He shoved the throttle partly open to keep the engine warm while he spiraled down toward the G-2 field. The stacks belched two blasts of yellow fire as the Hisso took up the load.

Strange jumped. A dark, weird shape, hovering near him, had been briefly revealed by that flash of light. It was only for an instant—a blurred sinister bulk like a flying monster from out of the past. He kicked around, ramming the throttle against the peg. He could see nothing now, but the feeling of menace returned with terrific force.

He hauled back the charging handles of the Vickers, pumped two bursts from the guns. They were aimed at the spot where he had last seen that black blur, but the tracers lanced on into space. He zoomed to release a parachute flare. His fingers found a toggle, pulled swiftly, but nothing happened. Belatedly, he remembered the ship had not been checked before his hurried take-off.

A fine mist had begun to fall. Suddenly, through that mist, he saw two luminous spots. They were small, yet wide-spaced, like the glowing eyes of some huge winged creature of the night. They narrowed to slits as the thing leaped toward him.

Strange reversed on grinding wings, shot up into an Immelmann. The glaring eyes twisted sidewise, and he could vaguely see the monster's queer, webbed wings.

The thing was a giant bat!

HE kicked around hastily, tripped his guns. The tracers made fuzzy white streaks in the mist. He saw where they struck behind the small, ugly head of the monster. The huge bat whirled at incredible speed. Its eyes were now so nearly closed that they showed only thin lines in the darkness. Headlong, it plunged at the Spad.

Strange rolled swiftly, tried to twist around behind the creature. But the night had swallowed it up. He threw the ship into a tight bank, seeking desperately to find the monster again. He could sense its presence, could feel that it was closing in . . .

He sprang up in the cockpit. The Spad's left wing-tip was on fire!

After that first instant of dismay, he threw himself down at the stick. Controls crossed, he sent the plane tilting down on the right wing. By the bright flame, he could see an ominous brown spot spreading in from the burning tip. It blackened quickly — as O'Rourke's face had blackened!

He shot a look at the altimeter. It showed 1600 feet. He booted the rudder, and the Spad howled down through the night, its wings perpendicular. But suddenly a black shadow whirled after him, and he saw once more the weird, glowing eyes of the giant bat.

The mists seemed to burn away be-

fore those glaring eyes. He kicked out of the slip as the creature plunged in at the Spad. Disregarding the blazing wing-tip, he whirled in a swift right turn. For a second, the webbed black wing of the bat came into his sights. He clamped the trips together.

The Vickers clattered dully above the screech of wings. He saw the monster hurriedly twist aside. He centered his sights for a split-second burst, but in that second, another dark blur leaped into view from above, and to his consternation a second giant bat pitched down at him.

His first precipitous slip had blown the flame away from the wing-tip, but now it blazed up fiercely again. Instantly both of the bats whirled away. Strange sent the burning ship down in a forward slip. It was now only five hundred feet to the ground, but he knew that the left wing might crumple at any moment. He peered over the right side, saw the G-2 field. It was shaped like a crooked finger, extending into the woods. He aimed the burning Spad cross-wind at a spot across the field. There was a winding brook somewhere near the clearing . . . it might offer the only chance if his clothes caught fire before he could jump . . .

Br-r-r-t-t-t-t-t! Br-r-r-r-t-t-t-t! The faint, staccato pound of machine guns cut through the moan of his ship, but he had no time to look up. The ground was leaping toward him. He took a hasty breath, shoved up his goggles, and brought up the tilted wing. The flames roared in toward the cockpit as he leveled off. He kicked with all his might, sent the Spad fishtailing around to the left. He braced himself, one hand at his belt.

The right wheel struck first, and the landing-gear tore off with a jolt. Then the right wing plowed into the ground with telescoping force. The impact threw Strange against the side of the cockpit, just as he opened his belt. He tumbled half-way onto the broken wing, scrambled head-first through the tangled struts and wires.

His flying-coat caught. He wriggled out of it, dived clear as the roaring flames swept over the pit and onto the smashed wing.

Two hundred feet from the blaze, he halted and stared upward. Several planes were whirling madly back and forth, their guns hammering furiously. He could see nothing beyond them, but he knew that at least one of the bats must be up there, hidden in the blackness.

With a high, crescendo shriek, one of the ships came plummeting to earth. It struck in the woods, and a pillar of fire

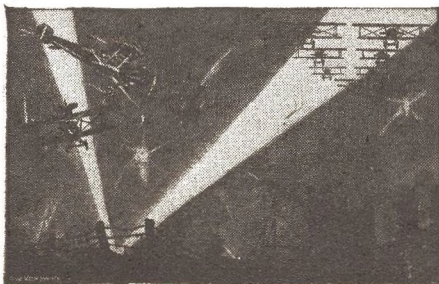

shot up. Then a Nieuport fell off in a spin. Four hundred feet from the ground, the wings stripped off, and the fuselage came down like a thunderbolt. The crash made a hellish sound. Charred pieces of fabric slowly fluttered downward.

White-faced, Strange helplessly watched the other ships. Four were left—three Spads and a Nieuport. Even as he counted them, one of the Spads rolled crazily and pitched toward the ground. By the glare of the flamer he could see its silvered wings turn dark. Then it crashed, and a second flamer lit up that scene of death.

The three remaining ships wildly plunged for the field. Strange held his breath, but the great bats did not follow them to earth. He ran across the narrow, crooked field as the three planes landed. The two flammers and his own burning ship cast their lurid glow back under the trees which concealed the station huts. A score of men—almost the entire personnel of the base—were gathered there in a frightened little group. No lights showed under the trees.

THE first Spad rolled to a stop near a D.H. and two captured German ships. Strange gave a start as the pilot cut off his engine and jumped down. It was Noisy Jay.

"Phil!" Noisy said shakily. "Good Lord—did you see them?"

Strange grimly nodded. The other Spad and the Nieuport taxied up, and he saw Tom Jay and the Intelligence pilot named Ball. Both men hastily threw their switches and leaped to the ground.

"Where's Kent?" gasped Ball.

"They got him, too," groaned Tom. He stared up wildly into the night. "My God, what if the others run into those things?"

Strange's haggard face took on a sudden alarm.

"Then more of the G-2 pilots are coming here?" he demanded.

"All of them," Tom said hoarsely. "Colonel Jordan sent us to catch up with you—you're to map out a plan—"

"Wait!" Strange wheeled toward the frightened ground men. "Switch on your searchlights!"

"Hold on there!" interrupted a harsh voice. "Do you want us all to be killed?"

Strange swung around to the dour-faced officer who had limped from the shadows. He recognized Captain Cloyd, the C.O. of the station, with whom he had had trouble more than one time in the past.

"There's no time to explain, Cloyd," he said curtly. "My pilots' lives are at stake—and those lights are going on!"

"I'm in command here," grated the other man.

Strange gave him a sharp look. "You're subject to my orders," he said coldly. "Get those lights on! Three men have died already when they might have been saved this way."

Cloyd's disfigured face twisted angrily but he turned and gave the orders.

"You don't know what you're doing," he told Strange sullenly, as the ground men hurried to obey. "Hell's broken

loose in this sector. Those damned things are striking right and left."

"And I've had proof that they're afraid of light," Strange said tersely. For a moment his eyes rested on the burning ships. Three of his men had died out there—perhaps in frightful agony. With an effort, he steeled himself, and turned to Ball and the Jays. "Now, what are Jordan's orders?"

It was Tom who answered.

"More reports came in right after you left. That 'invisible fire' has struck at a dozen places and—"

"I can tell you the whole thing," Cloyd broke in harshly. "I was the one who sent word to Colonel Jordan. Two night pursuit outfits are practically cleaned out. Troops moving up on the Chatigny-Moissons road were burned to death. Five French squadrons and two British bombardment groups—"

"Wait a second," said Strange, slowly. "What about these bats? There was no report on them before I took off."

"Nobody knows what they are," muttered Cloyd. "The first I heard was when the French put through a secret report yesterday, about an *escadrille* south of Nancy losing five pilots mysteriously. One man came back from a night patrol half insane and jabbering something about a huge bat killing the others. They thought he was crazy—and so did I until tonight."

Just then the first searchlight went on. Strange looked up as the beam probed the darkness. There was no sign of the giant bats, but the mist had become a steady drizzle and the visibility was even less than before. He glanced back at Cloyd.

"What do you think those things are?"

"God only knows," the other man said huskily. "What do you think?"

"I don't know any more than you do," Strange replied, "but I know where I can find out."

Cloyd and the others stared at him.

"I mean in Germany," he said grimly. He turned as the drone of several planes became audible. By this time the other searchlight was sweeping the sky. They all stood waiting tensely, until one after another the ships from Hanlon Field dipped down for hurried landings.

It was a mixed group which taxied across the clearing, with D.H.'s and Spads from the G.H.Q. hangars replacing the damaged G-2 planes. Strange beckoned to Ball as the last ship landed.

"Explain what happened, but try to keep them from getting panicky. Put two of them in the wireless hut and on the Chaumont wire, in case anything is rushed through for us. Have the rest wait here."

As Ball started away, Strange turned to the C.O.

"Captain Cloyd, I wish you'd come with me while I make a change. I'm depending on you to help me work out this plan."

"All right," said the other man, his voice a shade less sullen.

Strange gestured to the Jay twins. "I'll need you, too." He led the way past a machine-gun mount to the hut which served as a dressing-room for agents

going into Germany. "To save time, Tom, tell me the rest of Jordan's idea now."

"You're to detail half of the unit to go across tonight," Tom answered. His voice was a trifle unsteady as he went on. "You'll have to change things some, now that Kent and the others—"

"I know," Strange said dully, as Tom broke off. "But I don't understand why Jordan sent all of you here. There are only a few Boche ships—"

"The others are to be landed like ordinary spies," Tom explained a little tensely. "But the main reason is that General Blunt demanded the whole outfit after all the things that have happened in this sector."

THEY had reached the dressing-room shack. Strange closed the door as he followed the others inside. There was only one light turned on. He switched on the others, went over to the make-up table which he himself had had installed three months before. He removed his olive-drab blouse, took off a shoulder harness which held a short-nosed automatic. Cloyd had limped over to a sector map on the opposite wall.

"Here are the places which were hit tonight." He began to point out the stricken dromes and other locations, but Strange interrupted.

"Wait a moment. Would you mind getting Lieutenant Ball on that extension phone?"

The crippled captain limped over to the phone. Strange looked at Noisy Jay.

"Get into a Boche uniform as quickly as you can. You'll be one of the first to go across."

"What about me?" Tom asked, after an anxious look at his twin.

"Too dangerous for both of you to go over," Strange said crisply. "If your paths happened to cross, the game would be up. I want you and Ball to stay here and work with Captain Cloyd."

He sat down before the angled mirrors, stared into the center glass.

"It's a gamble," he muttered, "but it might work."

Cloyd looked around from the phone. "Your man's on the line," he said gruffly.

"Tell him I want to see him," said Strange.

The other man turned back. "Your senior officer wants to see you," he growled in the phone, and hung up.

Strange opened a drawer, took out several tubes of greaseless make-up and some lining pencils. As he set to work, he spoke over his shoulder to Tom Jay.

"Take that pad on the desk and list all of the pilots, with a space for separate orders. We'll use the regular overlapping 'search plan.' Somewhere across from this sector we ought to find a clue."

Just as Tom finished, Ball came in. Strange nodded to him in the glass, looked at Cloyd.

"Now, captain, if you'll indicate those places where the bats struck, I'll tell Ball what areas across the lines to mark for our operations."

Somewhat grumpily, Cloyd turned to the map and went on with what he had

started. Strange made swift notations on the pad Tom had handed him, then gave Ball his directions. Between quick decisions, he deftly built up new lines and shadows upon his face. Through the magic of make-up, his face took on a mocking cruelty. Suddenly Noisy, who had completed his change to *Feldgrau* uniform, gave an exclamation of astonishment as he saw Strange's altered countenance.

"Judas Priest! What's the idea?"

Strange looked at the reflection in the mirror.

"Then you recognize it?"

"I'd swear you were von Zenden, if I didn't know better!" Noisy replied.

Tom and the others were also staring at Strange.

"So that's how that devil von Zenden looks," muttered Cloyd.

"Yes," said Strange, "but only a few people know his real features, especially since the war. He used to be a professional impersonator and lightning-change artist—he was known as the 'Man of a Thousand Faces,' on Broadway. He's made good use of that ability in his four years with German Intelligence."

"But why make up like him?" queried Noisy.

"Just an idea for getting a quick lead on this affair after I'm in Germany," Strange answered. He glanced over his scribbled notes. "This covers the search-plan. I want to be sure that the pilots understand everything before I take off."

"I'll see that they get the information," said Cloyd. He limped across the room.

"Thanks," said Strange. He stood up, then paused thoughtfully. "By the way, did you get Colonel Jordan's code message about von Zenden and—*Fraulein Doktor*?"

"No," growled Cloyd. "What was it?"

Strange handed the notes to Tom Jay. "Take these orders over to the pilots while I tell the captain about this. I want them to memorize every detail as fast as they can. Also, please have that Albatross started for me."

HE turned back to Cloyd as Tom hurried out.

"Jordan must have forgotten to send word, or else the message has been held up in the excitement of all this other business. He wanted all G-2 stations warned that von Zenden is believed connected with this 'invisible fire' affair. That would also mean the bats, in light of what we know now."

"If he's as good as you seem to think," grunted Cloyd, "he'll be a hard man to catch. But what's this about *Fraulein Doktor*?"

Strange's made-up face hardened perceptibly.

"There's to be a dragnet thrown out for her. She tried to kill me tonight at Chaumont—and nearly succeeded."

"Hell's bells!" said Noisy. "So that's why Colonel Jordan made all the fuss about that nurse."

Strange gave him a puzzled look as he put on his shoulder harness and turned to the rack of uniforms.

"Then he didn't tell you who she was?"

"No, just said she was a spy. Are you sure she was *Frau* Doktor?"

"Positive," Strange said curtly. "I've run across her three or four times since I've been in G-2. We captured her once, but she escaped, though we managed to wreck her plans. It's evident she's held a grudge all this time against me."

Cloyd had listened with a thinly veiled sneer on his disfigured face. "I never thought you'd be afraid of a woman," he said as Strange finished.

Strange eyed him coldly. "I said nothing about being afraid of her."

There was a brief silence, then Noisy sighed dismally.

"Lord, it's hard to believe that such a pretty girl could go in for murder."

"Don't let her beauty deceive you," Strange retorted. "After what happened tonight, I'd rather face the great von Zenden himself."

Cloyd spoke with a dour humor.

"That's simple. Just turn around and look in the mirror."

Strange gave him a queer, grim smile.

"It's even simpler than that. *Put up your hands, von Zenden!*"

CHAPTER IV

SUICIDE CANYON

A STUNNED look came into the disfigured face before him. Strange took a step forward, leveling the gun he had snatched from his holster.

"Up, I said!"

With a snarl, the other man raised his hands.

"You fool, have you lost your senses?"

"It's no use, von Zenden," Strange said coolly. "The game's up."

His captive flung a fierce look at Ball and Noisy Jay, who were staring in blank amazement.

"Grab his gun, you idiots!" he snapped. "He's stark mad!"

Noisy gazed open-mouthed at Strange. "Holy mackerel! Are you sure about this, Phil?"

"Hold his arms tight, and I'll show you," Strange replied.

His two dazed pilots hastily obeyed. He turned, wet a small sponge with alcohol, and rubbed it vigorously over the other man's face. The ugly scar vanished, and with it the surly countenance of Captain Cloyd. In their place were revealed the true features of the "Man of a Thousand Faces." Ball gaped from him to Strange.

"My Lord, captain, if you had your blouse on I wouldn't know which was which!"

"In that case," Strange said drily, "I'd better keep it off."

He quickly searched the Prussian. Von Zenden, after one murderous glare, had let his face relax into a mocking smile.

"I must be slipping, to let myself be tricked so easily."

Strange laid a small pistol on the table, briefly examined a wallet and credentials which von Zenden had carried.

"Perhaps I can save you the trouble,"

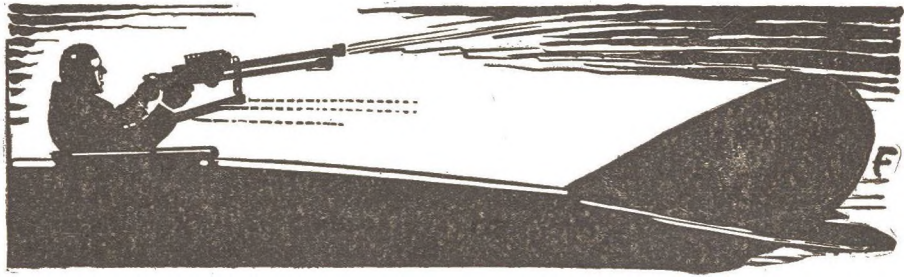

the Prussian said in a smooth voice. "The wallet contains money for bribes. The credentials were forged for this particular role."

"Thank you," said Strange, ironically. "We'll search for the more important items later."

"It will be wasted time," von Zenden shrugged. He looked with an amused contempt at Noisy Jay and Ball, then glanced back at Strange. "I should be interested—if it is not too much of a secret—to know how you discovered me. I rehearsed this part rather carefully before—shall we say—eliminating Captain Cloyd."

Strange's coolness matched the Prussian's.

"I didn't suspect until a few minutes ago. You were a little too much upset when you saw my face made up like yours."

Von Zenden's lips curled.

"And I suppose the Mental Marvel would have been completely unmoved?"

"I still wasn't sure," Strange said calmly, "until you tried to seize the first opportunity to get out of here. And then the attempt to get us looking toward the mirror so you could draw your gun—"

"Very brilliant," mocked the impersonator.

Strange picked up his pistol, gestured for Noisy and Ball to stand aside. At gun-point, he marched von Zenden backward against the wall. The spy had straightened, and he no longer limped. A look of veiled puzzlement came into his shrewd eyes as Strange stared over the pistol at him. Then the G-2 ace thought he saw a flicker in the depths of those narrowed eyes.

It was gone at once, and under his penetrating gaze von Zenden's eyes slowly assumed a glassy stare. A minute passed, while the Prussian looked unseeingly into Strange's face. Strange reached out and lifted the spy's right arm from his side. It remained where he placed it.

"You've got him, Phil!" Noisy whispered excitedly. "He's hypnotized, all right!"

Strange made a warning motion, stepped closer to von Zenden.

"How many agents do you have on this station?" he asked in a low voice.

The spy's lips moved soundlessly. Strange repeated the question.

"Two," the Prussian said hoarsely, like a man who talked in his sleep.

"Who are they?" Strange demanded.

"Mechanics—bribed by—" the words were drowned by a sudden roar from the ship being warmed on the line.

Strange gave a start as the German engine boomed. Only an instant did his

eyes shift from the man before him, but in that instant von Zenden leaped. A furious blow knocked the gun from Strange's hand. As he dived after it, the Prussian sprang to the light switch a few feet away. The room was swiftly plunged into darkness.

Strange heard the door bang open as von Zenden raced out toward the line. Noisy Jay and Ball charged past him, yelling at the top of their voices.

"Hold it!" he cut in hastily.

"But he'll escape!" cried Ball.

"That's what I want him to do!" Strange said in a lowered voice. "Give him a few moments' start."

"Judas Priest!" gasped Noisy. "You mean you framed all this—let him think he fooled you on that hypnotism stunt?"

"Yes, but it may backfire if we don't watch out." Strange lit a match, pressed the switch buttons. As he seized his olive drab blouse and ran toward the door, Tom Jay dashed up.

"Everything's set!" he exclaimed.

"Good boy," said Strange. "Follow those orders—come on, Noisy!"

THE engine of the Albatross had lessened its roar, but as they neared the clearing it boomed out again, and they saw the Boche ship hurtle away from the line. Guns barked from three or four points under the trees, then the thunder of a Liberty motor drowned everything. With Noisy at his heels, Strange reached the Chaumont D.H. which he had instructed Tom to have started as soon as von Zenden fled.

"Take the rear pit!" he flung at Noisy, and climbed hastily into the front. A searchlight pointed up as the escaping Prussian zoomed. Strange pushed the throttle, and the already warm Liberty revved up with a deafening bellow. He snapped his belt, jerked down his goggles as the ship raced down the clearing.

The embers of a smoldering Spad glowed redly off to the left. Strange's eyes were stony as he crouched over the stick. If his plan succeeded, those unfortunate pilots would be avenged before many hours had passed. He lifted the thundering ship with a skilled touch, climbed after the Albatross. The mist had thinned, and two searchlights now feverishly probed after the German ship.

Suddenly the Albatross rolled wildly to the left. Strange climbed at full gun, straining his eyes to see the other plane. Abruptly, the twin Lewises behind him broke into a fierce chatter. He spun in his seat. Noisy had whirled the twin-mount, was firing madly at the diving Boche.

Spandau slugs pounded into the two-

seater's tail, then the spy hurriedly zoomed. Strange hurled the heavy D.H. around as though it were a Spad. The single Vickers before him was already set for action. He squeezed the trip, but made no effort to center the tracer track upon the Albatross.

Von Zenden whirled in a tight bank. Strange jerked the two-seater around on groaning wings, and the Prussian's fire stabbed off into the night. Two more ships were speeding across the G-2 field for hasty take-offs. As the spy saw them zoom up he reversed with an expert hand and plunged into the darkness.

Strange was after him in a twinkling. The searchlights slanted down across the field, and then quickly faded out. For a few seconds he could see nothing in the ensuing blackness. He stood up, peering anxiously from side to side. Then to his relief he saw what he sought—two crude glowing crosses below and to the right. He swung in behind the luminous marks, eased the throttle and kept the distance even.

Reaching down in the cockpit, he felt for the ear-phone helmet which was regular equipment for all G.H.Q. two-seaters. He exchanged it for his own, switched on the circuit and pressed the button for the signal light in the rear. Almost at once, Noisy's familiar yelp came through the phones.

"Where the hell are we going?" he demanded.

"Wherever those crosses go," Strange replied through the transmitter cup.

"Crosses? What crosses . . . for the love of Pete, how'd you work that?"

"They're made with phosphorous from tracer bullets," Strange explained. "Tom or some of the others put them on the top wings of the Albatross so we could follow it in the dark. Von Zenden can't see them from his cockpit."

"I get it," said Noisy. "You put all the orders for this business in those notes you gave Tom."

"That's right," said Strange, "but I was afraid any second von Zenden would catch on. I lied to him about the time when I began to suspect him. He made me wonder almost at the start, staying back behind that machine-gun. I know now he was waiting until he was sure the G-2 unit hadn't come after him. Then he objected to the lights. But what made me really suspicious was that argument about his authority. Cloyd and I thrashed out that subject ten days ago, after he messed up one of Jordan's plans."

"And you knew he was von Zenden then?" exclaimed Noisy.

"No, but when we reached the dressing-room I had a strong hunch. There were things on that make-up table which I never left there, and they were laid out for fast work. Also, he kept across the room at first, away from the light. But the final proof was when he avoided naming me on the phone—he didn't know whether the real Cloyd knew me as Strange or by some other name. From then on, everything he did added up to von Zenden."

"I've got to hand it to you," said Noisy, "scoring a put-out on *Fraulein*



Doktor and von Zenden all in one evening."

Strange was silent for a moment, his eyes fixed absently on the crosses which seemed to float along in the night.

"Noisy," he said abruptly, "I'm going to tell you something, so that if I don't get back there'll still be a chance for you to tell her, perhaps after the war."

"Her?" came Noisy's astonished voice. "You mean a message to *Fraulein Doktor*, after she tried to murder you?"

Strange stared ahead into the night. "She didn't try to kill me," he said dully. "She was trying to save my life."

"Say, are you clear nuts?" Noisy howled.

"Not entirely," said Strange. "You see—I knew her before the war. There will never be anyone else."

"Good Lord!" he heard Noisy say in a stunned voice. There was a long silence. "Phil—I never dreamed—oh, hell, what a rotten trick life's played on you!"

Strange smiled crookedly in the dark.

"I just wanted you to understand," he said. "If anything happens, and you get through, tell her sometime that I didn't mean what I said. I was a little dazed, but even then I didn't believe—"

HE broke off sharply, for the two glowing crosses had swept into a circle. He followed, keeping well above.

"What's he up to?" Noisy asked tensely through the phones.

"I think he's trying to be sure he isn't followed," Strange answered. He looked back into the gloom. "See if you can spot the other ships."

"What others?" Noisy said quickly.

"The two captured Fokkers which were at the station. In those notes I gave Tom, I told him to have Dougall and McRay follow the D.H., see where we land, and fly back with the information. There's a phosphorous circle on our top wing to guide them—or there should be."

"I can't see any exhaust flashes," Noisy reported, after several moments. "But the ships would have to be pretty close for me to see anything."

The crosses marking von Zenden's plane ceased to move in a circle. Strange looked at the compass as he matched the spy's new course.

"He's heading toward Colmar, probably for some spot in the Vosges Mountains," he told Noisy after a swift calculation. "It's a good thing I didn't have to use my first plan."

"What was that?" Noisy's voice came through the phones.

"Even before I left Chaumont, I intended to go across, made up as von Zenden, but I meant to go to the German Third Army Intelligence base. Colonel Jordan found an identification pin similar to the ones von Zenden used to leave as his symbol in his first series of spy-murders. It was evident that he was connected with this thing. I knew he would be the key man in France, so I thought I could go over and bluff my way at Third Intelligence, and learn the secret. But apparently the scheme is being controlled from a more distant spot."

"Well, what are we going to do now?" Noisy said anxiously.

Strange gazed down grimly at the two crosses, which shone weirdly from the night.

"We'll trail him until we find where he means to land, then we've got to shoot him down. He must have no warning; it's no time for any gallant gesture. Thousands of men may go like O'Rourke and Kent and the others, if we fail tonight. We'll try to crash him away from their base, to give us enough time before anybody can reach the wreck. I'll land, pretend to be von Zenden, and pass you off as one of my agents. We'll have to learn the truth quickly and get away before they discover the trick. But if I'm caught, you're to run for it, remember. Take what information you can to Jordan—and don't forget the other thing I asked you to do."

There was a pause, while the D.H. roared on through the night, then Noisy spoke hesitantly.

"Back there at the station, you—well, you said a lot of things about *Fraulein Doktor*—"

"That was only to clear her of any suspicion von Zenden might have," Strange explained.

Noisy did not answer; and Strange knew that his young aide was wondering about the incident at Hanlon Field. But he made no attempt to explain further, and a long silence fell. He glanced over the instrument board. It was three minutes to one. They were flying at six thousand feet, and slowly climbing through the solid blackness. Now and then the two-seater plunged into a cloud. The dampness reminded him of the cloud into which he had zoomed just before the first giant bat had appeared. His eyes narrowed thoughtfully. It was evident that the invisible fire was turned into ordinary flame when it touched water. The Spad's wings had been wet from the mist, and the dark spot on the left tip had blazed as a result.

His gaze shifted back to the clock. They had been in the air thirty minutes. That meant they were well into Germany; clouds had obviously hidden the lines.

THE glowing crosses led onward like some will o' the wisp, rising and falling as the air became less steady. Gradually the clouds thinned out, and through breaks below he saw occasional lights. Stars appeared through openings above. In twenty minutes more, the sky

was clear, but now the ground showed only as a solid blackness. Strange leaned out, vaguely glimpsed the jagged outlines of mountains against the stars.

"Judas!" Noisy suddenly yelped through the phones. "Look at those rocks. This crate's going to need a pair of claws instead of wheels, if we squat down anywhere around here."

"He must be heading for a plateau," Strange returned. "But how he ever expects to find it—"

He nosed down, for the luminous crosses had begun to settle even as he spoke. With the Liberty at half-speed, he followed the Prussian's ship. The altimeter hand slowly dropped to the five thousand mark, kept on dropping. Strange warily closed the gap, his thumb hovering over the single trigger trip.

The Albatross turned, circled widely. Von Zenden was apparently trying to locate his goal. Strange stared down, but he could see only dark rocks, with a hint of even darker canyons. They were getting perilously close to the jutting peaks when a double blast of flame spurted from the stacks of the Albatross. He hastily throttled the Liberty so that its roar would not be heard in the breaks of von Zenden's signal.

The spy signaled again, then a third time. A red light hurriedly blinked from a point below and on the left. Then it shone steadily, and a moment later two strings of green lights flashed on. They made a lane which led away to the right of the red light.

The Albatross had dipped sharply when the green lights appeared. As Strange pitched the D.H. after it, Noisy gave an exclamation.

"Hell's bells! We're heading into a canyon!"

"It must lead to the base," Strange rapped back. He dropped the transmitter cup, crouched over the stick, his eyes glued to the crosses on the Albatross. Dark, threatening walls swept by on both sides. He braced himself for a swift turn in case von Zenden made a mistake in that perilous descent.

The spy was flying straight for a point between the first pair of green lights. Strange felt a sudden tension come over him. It was more than a natural tautness from that dangerous flight. Something evil was about to happen!

His swirling thoughts crystalized into a swift premonition. Von Zenden had been signaled that they were following him! He was leading them into a trap!

With a swift turn, the Albatross whipped to the left, away from the lines of green lights. But for that flashing presentiment, Strange could never have followed. Stick and rudder jerked at his hasty touch, and the D.H. thundered after the German ship. A moment later, a grinding crash sounded above the Liberty's roar, and flame blazed up behind them. Then a horrified cry came through Strange's phones.

"Good God, Phil! Either Doug or Mac hit the rocks!"

Strange groaned, then a savage light came into his eyes. His thumb snapped the trip hard against the stick. Von Zen-

den had nosed down slightly, was flying straight for the same red light. The glare from the blazing plane behind dimly showed the branch canyon into which he had swerved: Strange charged after him fiercely.

As the tracers shot past the spy's head he jerked around in astonishment. The G-2 ace grimly aimed his gun. Von Zenden threw himself down, and the Vickers burst slashed above his head. The next second the Albatross lanced up in a furious zoom.

Strange backsticked, and the D.H. roared up between the canyon walls. Noisy was hammering out short bursts with the Lewises. Von Zenden had twisted at the top of his climb, was veering off into the darkness. Strange banked after him, then took a quick look below.

The Fokker flown by the ill-fated G-2 pilot was blazing at the foot of a precipice. The green lights were still turned on, and with a shiver Strange saw how close they, too, had come to that same end. For those green guide-lights had led the pilot to his death. The space from which von Zenden had swerved was a short, blind canyon ending at the precipice. Flying between the green lights, the Fokker had crashed headlong into the rock wall. The flames lit up other wrecked ships, some of them burned to tangled skeletons, and Strange knew what had happened to the missing French night-patrol pilots.

The Albatross had plunged over a jagged ridge and disappeared. Strange climbed steeply, trying to spot the Prussian's ship. A wild yell from Noisy rang in his ears. He spun around, went rigid at what he saw.

Sweeping down from the gloom was one of the giant bats!

CHAPTER V

THE BLACK ROOM

STRANGE rolled frantically into a vertical turn. A blurred something flashed past his right wing-tip. Two hundred feet away, on a rocky slope half lighted by the flames below, a dark, round spot appeared. It spread, flowed down the rock like some viscous liquid. A heat mirage danced above it as it moved.

With another violent bank, Strange sent the D.H. thundering past the bat. Noisy's gun clattered fiercely, but the monster whirled again at the ship. Strange reversed, pitched the two-seater over the edge of a ridge. A second dark splotch appeared on a jutting rock as he dived. He twisted away, fighting back a surge of primitive panic.

If he lost his head now, they were finished. Those dark spots were obviously the source of the invisible fire, probably caused by chemicals discharged in soft-shelled containers. Undoubtedly, it was one of these containers which had slid over the hutment roof at Hanlon Field, striking the unfortunate O'Rourke.

He dived toward the flame-lit area, cast a hasty look backward. The black-winged monster was turning away, as

he had expected. He pulled up in a tight chandelle. As the D.H. corkscrewed upward he had his first clear glimpse of the bat.

Though he had guessed from the start that the bats must be machines, he had still been puzzled. How the pilots could see to attack in the dark was a mystery. The two above the Bois d'Abbecourt had struck with unerring aim in pitch blackness.

He leaned out for a swift scrutiny as the two-seater chandelled. He saw at a glance that the night raider was a tailless pusher monoplane, with black, webbed wings patterned after those of a bat. Two curious knobs, like protruding eyes, showed at the sides of the small, hooded low cockpit which resembled a bat's head. These knobs, he surmised, must be the tips of compression tubes for launching the chemical bombs.

The bat-ship was climbing swiftly away from the flame-lit canyon. Strange ruddered sharply, tripped the Vickers. The bat-ship darted off to the left, Strange's tracers barely missing its pusher prop. Almost instantly, there was a movement behind the blurred disc of the prop, and bullets drilled the two-seater's wing. Strange swore. There was obviously an emergency gun, flare-shielded and using tracerless bullets, in the rear of the raider.

He kicked out of the fusillade. The bat-ship turned quickly, and the compression tubes slanted sidewise in hasty aim. Strange shoved the stick forward, dived under the raider.

"Look out—von Zenden!" Noisy's swift warning came through the phones.

The Prussian's ship suddenly leaped from the dark, howled in at the D.H.

Strange zoomed into a climbing turn, and Noisy raked the Albatross with a fiery blast. Von Zenden hurriedly twisted away, but one of his slugs had found a mark. The Liberty broke its steady thunder, sputtered and went dead.

Strange nosed down, his made-up face grimly set. Even if they were not killed in the landing, they had hardly a chance in a thousand of getting out of the canyon before the Germans could seize them. He came to a quick decision, swung the two-seater toward the spot where the red light had shone. It was gone now, and the glare of the burning Fokker sent only a vague light into the canyon, from where it had struck beyond the turn.

In the semi-gloom he saw a short, level stretch of canyon floor, then a long, jagged hump which rose to a height of at least thirty feet. At the left, and almost even with this sudden rise, was the dark bulk of a house. He thought he saw a road winding up the steep slope.

He fish-tailed the D.H. with a violence that made it groan. The only possible landing place was that level stretch immediately before him. If he missed that it meant a bad crash on the rocky hump.

Abruptly, the red light reappeared—directly in front of the ship. Then to his amazement the rocky wall was split by a vertical line, and the two sections hastily folded back, revealing themselves as camouflaged curtains.

Strange had expected to find the German base beyond that jutting hump. Helplessly, he realized that the ship was rolling right into the base. The "hump" was nothing but a framework extending across the canyon, camouflaged to hide the space beneath.

"Holy smoke!" he heard Noisy moan. "We're washed up now!"

Strange snatched at the transmitter cup.

"We've still a chance! Sit tight!"

The two-seater rolled through the opening. He shot an anxious look around, caught a faint glimpse of bat-ships, tanks and supplies on both sides near the entry. Beyond was blackness. The D.H. came to a stop in the shadows, and instantly, he jumped up in the pit.

"Hilfe! Help!" he shouted. "Mach Schnell!"

THERE was a rush of feet, and he dimly made out several figures in the darkness. He expected a hurried flashing of lights to show his face, but instead there was a chorus of excited voices.

"It is *der Oberst!*" bawled one man. "Put down your guns!"

Strange hid a start. *These men could see perfectly in the dark!*

"Gott sie Dank, that we did not fire at once!" exclaimed the man who had given the order. "We thought you were in the other ship and this one was—"

The intermittent roar of a Mercedes cut him off. Strange jumped to the ground, stared back toward the opening. He could see the Albatross gliding down, barely discernible by the fading glare of the burning ship. Then Strange whirled to the almost invisible figures about him.

"That pilot is a Yankee spy!" he snapped, "Get back to the sides—the *Leutnant* and I will handle him!"

"But, *Herr Oberst,*" protested one of the Germans, "he might kill you. Why not let us—"

"Follow my orders!" commanded Strange, with a perfect imitation of Prussian arrogance.

"Ja, *Excellenz!*" the man said hastily. "We will stay back until you need us."

Noisy sprang down as the Germans ran into the deeper shadows. Strange fumbled out in the dark, caught his arm.

"Quick, take these matches!" He gave Noisy a box snatched from his pocket. "What are you going to do?" Noisy whispered.

"Take care of von Zenden. And here's your part." Strange rapidly went on in undertone, then pulled Noisy to one side as the Albatross came taxiing toward the entrance. Its engine was idling, and the exhaust-stack flashes made it easy to follow the plane as it slowed nearby.

Strange dashed to the left side of the fuselage. There was a sudden blaze on the right side, as Noisy touched off the whole box of matches. Von Zenden had bent over to switch off the engine. He jumped up, then frantically snatched at a flare-pistol. Strange swung, with his weight behind the blow. The Prussian pitched back, slumped over the side of the pit.

Noisy had dropped the burning matches, and Strange saw him drag von Zenden from the ship. He raced around the tail of the plane and bent over the senseless man. Five or six matches were still flickering, and as he had hoped he saw oily smears on the canyon floor where a ship had stood. He turned von Zenden over, letting his face roll through the black grease.

"Pretend to be searching him, he whispered to Noisy as the last match burned out. "They'll be able to see us now."

In a moment a subdued voice spoke from the dark.

"Is everything all right, *Excellenz?*" "Yes," he said calmly, "the pig will not cause any more trouble. "*Leutnant*, did you find anything?"

"No, *Herr Oberst,*" Noisy replied. "His pockets are empty."

"Perhaps one of us should help search him," offered a husky voice from the shadows, "since the *Leutnant's* eyes are not conditioned."

"It is not necessary," Strange returned. "*Leutnant* Weims is a member of the *Nachrichtenamt*, and skilled in such work."

There was a sound of some one running toward them. Strange tensed in spite of himself. If he could only see a little more . . .

"*Herr Oberst,*" said a breathless voice, "the *Kommandant* is anxious to see you."

Strange thought swiftly.

"Tell him there is nothing new to report, now that this spy is caught." He turned toward the vague figure of the senior officer present. "A distributor wire on the Liberty motor was clipped by one of that *Hund's* bullets. Have it spliced at once—we must return to France immediately."

He could hear men clambering about the D.H., then one of the Germans reported.

"The distributor head is cracked, *Excellenz*, and two wires shot away. Perhaps you had better take the Albatross and leave *Leutnant* Weims here."

"Impossible," snapped Strange. "He has been specially trained for a vital role in our plans. Also, I must reappear in this very De Haviland, or I shall be suspected. Replace the wires and tape the distributor head tightly."

THE senior man gave an order, and Strange heard mechanics darting for tools and equipment. He looked toward the entrance, hiding his anxiety, aware that a dozen pairs of eyes were probably on him.

"Franz must be waiting until the fire from that Fokker has gone out," said one of the Germans.

Strange wheeled.

"Signal him to refrain from landing until I have taken off!"

There was a pause, then the senior Boche present spoke nervously.

"But, *Excellenz*, this work on your plane will require at least fifteen minutes, if it is to be safe. And Franz may be low on fuel—he was one of those who went on the special mission to Chaumont tonight."

"Then signal him to wait until the last possible moment," Strange ordered, holding his tone to one of cold annoyance. "That fire will not die out completely for ten minutes or more. He would probably land just as I was ready to take off—and even now this delay may prove fatal to our plans."

He heard the senior man move away, muttering under his breath. A second or two later, a phone jangled in the dark base.

"It is for you, *Herr Excellenz,*" a German reported, after a moment. "Here, I will guide you."

Strange silently cursed the darkness as he was led to the phone.

"Ja?" he said guardedly as the instrument was put into his hands.

"*Oberst* von Zenden?" came a gruff, hurried voice. "*Der General-Kommandant* is fuming because you have not reported. You had better hurry—you know his bad temper."

"But the delay may ruin our work," Strange said emphatically.

"It will take only a few minutes," said the gruff Boche at the other end of the line, "and Schwartz tells me your plane will not be ready for a while."

"Very well," Strange responded, "but try to show him how important it is that I am not delayed."

He hung up, turned and spoke crisply across the darkened space.

"*Leutnant* Weims, I have been called to see the *Kommandant*. If I am not back when the plane is ready, take off without me. Land at our agreed contact point, and deliver the orders I mentioned. I shall follow with the Albatross."

"Ja, *Herr Oberst,*" came Noisy's strained voice. "I understand."

Grimly, Strange went along with the German who was his guide. The chances of his leaving this base alive were dwindling every second. Von Zenden would probably recover his senses in less than half an hour, though he had struck the spy a terrific blow. Also, the bat-ship might land, and the pilot would be sure to expose the deception, though he now undoubtedly thought the men in the D.H. had been killed or captured.

There was a chance that Noisy might escape with the information. But as Strange went up the path with his unseen guide, his heart was leaden. He had planned this maneuver to learn the truth about the invisible fire and the bats.

He had learned what he intended—but he had probably doomed Noisy and himself, beside causing the death of the G-2 man who had crashed against the rocks.

"Here are the steps, *Excellenz,*" his guide said respectfully.

WITH the Boche holding his arm, Strange silently ascended. The man's ability to see so well was almost uncanny, but he knew now how it had been attained. The bat-ship pilots and the personnel at the base had evidently been isolated at this place for weeks, probably three or four months. Kept in total darkness, their eyes had become accustomed to the condition, so that

after that long period they were able to see as well as nocturnal creatures. This also explained the bat-ship pilots' hasty swerving away from light or fire. Any bright light would blind them. He had counted on that to aid in the capture of von Zenden. The flare of the matches had kept the Germans from seeing the Prussian's face during that brief action.

The possibilities of the Boche scheme were almost terrifying. As already proved, the Allied night patrols would be helpless against the bat-pilots; the Germans could easily destroy all the night-flying squadrons within the next forty-eight hours. The night bombers would go the same way, and unless the bat-pilots were killed the entire Allied air service would soon be wiped out. Troops on the march, in camps, or even entrained would be easy victims to the invisible fire discharged from the night raiders. Supply bases, ammunition depots, even factory cities far behind the lines would be as easily destroyed by the silent, deadly bat-ships.

The story of the giant bats would spread like wildfire over the Western Front. Beside the practical value of the weird black ships, with their muffled engines and instruments of death, the psychological result was sure to be tremendous. Even those who knew that they were some kind of machines would still feel the fear of something unknown. The excitable French would be quickly terrified . . . yes, the Germans had planned well!

Strange's somber thoughts were broken as his guide opened a door at the top of the stairs. They stepped out upon rocky ground, and he could see the stars above the canyon. A short distance away was the dark house he had already seen.

"We could have gone through the basement, *Herr Oberst*," said the man who was guiding him, "but this way is shorter."

"Yes, I know," said Strange. He looked to the right, saw the rough outlines of the "hump" the Germans had created. In the faint starlight it appeared like desolate rock. Even in the daytime, from any distance, he knew it would be difficult to tell that it was camouflage.

They entered the gloomy building. There was no one outside, but a sentry just within spoke briefly to Strange's guide. Strange could see nothing but a speck of purple light ahead. The Boche with him led the way toward this, then turned. Another tiny light, this one red as a ruby, appeared a few yards beyond. Strange saw a bronze knob beside it as they halted.

Through the closed door he heard voices, one gruff yet deferential, the other higher pitched and imperious in tone. Both voices ceased as his guide knocked.

"*Wo ist es?*" demanded the gruff voice.

"*Unter-Leutnant Schwartz*, with the colonel," said the man beside Strange.

The door was opened, and a hairy hand appeared in the ruby glow. It took Strange's wrist, drew him inside. Schwartz stepped back, and the door

closed, leaving the room in inky blackness. Almost the instant he entered, Strange sensed a quick tension. To his sensitive brain, already sharpened to overcome the handicap of darkness, it seem like sudden fear. But there was no reason for them to fear him . . . could it be suspicion—had they already penetrated his disguise?

"Von Zenden!" came the high, imperious voice. "What do you mean by keeping me waiting for your report?"

Strange answered coolly, basing his tone on his knowledge of the Prussian's



manner and his importance to Germany.

"Is it better, *Herr General*, to make an official report—or keep our scheme from failing?"

The unseen *Stab-Offizier* snorted.

"There has already been one failure, according to the *Fraulein* here."

Strange stood motionless. Karol was there in the Black Room!

"And what was this failure, *Fraulein*?" he asked ironically.

He heard her draw a quick breath, then she answered in a low, hurried voice.

"It was about—Captain Strange. He escaped the chemical fire death, and is now hidden somewhere in Chaumont."

EVEN in that moment of danger, Strange felt his pulses leap as he caught the purpose back of her last words.

"The coward *Schwein!*" he said contemptuously. "I suppose it would be useless to try to get at him now."

"Yes," Karol's low voice said from the darkness, "the town is too well guarded, after what happened. Searchlights are constantly sweeping the sky, so it would be dangerous for the bat-planes to go near there."

"Well, it is not important," said Strange.

"When I saw you at Strasbourg," the Boche general broke in sharply, "you said it was most important to have this Brain-Devil killed or captured."

"It seems I over-estimated his shrewdness," Strange replied, "also his courage. *Herr General*, the Yankee pig will not bother us now."

"Something must have gone wrong,"

insisted the staff officer, "or you would not have come here three hours ahead of time."

"I came here because of the carelessness of our own men," Strange returned. "An exhaust shield or something on one of the bat-planes must have become loosened. A glow was seen by G-2 pilots soon after the action of Chaumont, and a captured Fokker was hastily loaded with small fragmentation bombs. The Yankees evidently thought a German plane would be safer in the air, after what had occurred. I heard about it at the Bois d'Abbécourt station, and made an excuse to take off in a De Haviland with one of my agents. I estimated the course and intercepted the bat-plane near here. The Fokker was evidently waiting to locate our base, and there was an Albatross with it, another captured plane. I managed to trick the Fokker pilot into the blind canyon, and the other man followed me down after crippling my engine. He has been overcome."

The gruff-voiced German spoke for the first time since leading Strange into the room.

"Good work, *Herr Oberst!* The Fokker pilot might have dropped the bombs on the base if he had followed the bat-plane undisturbed. I will punish the pilot and the gunner for their carelessness."

"Very well," said Strange quickly. "But I must return to France at once. I must not lose the key position I have built up in American Intelligence."

"A minute more will make no difference," interposed the general. "Major Vetter, will you guide us to the light room? I wish to have von Zenden point out something on our operations map."

Strange stifled a groan. The hall door opened and he saw the dark red glow. As he started out, a figure brushed against him, and he caught the haunting odor of a delicate perfume. He thought Karol was gazing at him, but the dimness of the light kept him from being sure.

With Vetter leading them, they moved slowly along the dark hall, turned and stopped before the faint purple light. Another bronze knob was visible.

"The switch button is on the right as you enter," the Boche major said. "Please wait till the door is closed, or the light will blind me."

Strange groped his way into the room after Karol and the general. He heard the door shut, then there was a click and bright lights flashed on. Even that short period in absolute darkness had had an effect, for the glare briefly dazzled his eyes.

Then he saw the Staff officer, a beefy German with a row of medals on his bulging uniform coat. Just beyond him stood *Fraulein Doktor*. She had changed her nurse's garb for the simple dress of a French peasant girl. Her face was turned toward the general.

The staff officer looked around the room, crossed it, and closed a door on the opposite side. Just before it closed, Strange saw three or four cots on which men were sleeping. Apparently there was a small force of Germans whose

eyes were normal, and who were kept for daylight work.

"Here is what I want," said the general, turning to a huge map of the entire Western Front. "Point out the casualties inflicted during this first test, as reported to American Intelligence. I have the reports of the pilots—except the one who has not yet returned—but I intend to see how accurate they are."

"There may have been some reports after I took off," Strange said offhandedly. He stepped toward the map, but wheeled as Karol gave a sudden gasp. Her eyes were on his left wrist, and as he swiftly glanced down he saw a tiny thread of blood which had trickled down from the needle hole. She looked up at him, her face slowly paling. He waited, looking straight into her eyes.

"What is the matter?" demanded the general, turning impatiently.

Strange calmly wiped away the trickled of blood.

"Nothing but a slight cut which seems to have re-opened." He picked up a colored crayon, began to mark the spots von Zenden had mentioned in his role of Captain Cloyd. But his mind was in a tumult, for he could feel Karol's searching eyes upon him.

That she knew him, he was certain. What would she do? Would she let him escape—knowing that he would rush a bombing armada to destroy the bat squadron? Or would her loyalty to the Fatherland . . .

Without warning, the hall door was thrown wide open. Strange whirled, but it was too late to draw a pistol.

There in the doorway, smiling grimly over a Luger, was von Zenden!

CHAPTER VI

BLINDED BY FIRE

"**LIEBER Gott!**" cried the general hoarsely, as he saw the Prussian's grime-streaked face.

"Don't be alarmed, General Kronach," von Zenden said sardonically. "I am the real one. This *Teufel* you have been entertaining is Captain Strange."

"But—but I don't understand," gasped the fat staff officer. A sudden suspicion came into his eyes. "How do I know you are not the *Spion*?"

Without moving his head, von Zenden spoke to some one in the dark hall.

"*Rittmeister* Buhl, identify me for the general."

"He is *der Oberst, Herr General*," came the hasty response from back in the shadows. "I cannot come closer—the light has already partly blinded me, but you surely know my voice—"

"*Ja, ja!*" said General Kronach. "But explain this thing!"

"The two spies fooled us all," said the unseen *Rittmeister* angrily. He explained how Strange and Noisy had tricked them. "But later, when the colonel began to regain his senses, the other spy acted most queerly—apparently not realizing we could see so well in the dark. I investigated and when I saw *Herr Oberst's* face—"

"I understand now," interrupted the staff officer, "at least what happened

from then on. But—" he stared from Strange to von Zenden—"it is still incredible that he should be so exactly like you. He must be as skilled in the art of make-up as you are."

The Prussian looked at Strange with a sneer. "He has probably been practicing this part for months, in the event that our paths crossed."

Strange could feel the rage back of his sneering tone. Von Zenden had always boasted that he stood supreme in the art of impersonation.

"But how did he know you were coming here?" persisted the fat general. "He must have learned all of your plans."

"It was an accident," von Zenden replied. His voice lacked its customary suavity as he described how Strange and the G-2 unit had arrived at the Bois d'Abbecourt station, and the events which had followed.

"Himmel!" exclaimed Kronach, as the Prussian mentioned the two Fokkers which had taken off after the D.H. "But only one Fokker was downed. The other man must have raced back to France—he will bring back a bombing force!"

"And the rest of their G-2 air section," said von Zenden, with a mirthless smile at Strange. "All of which will save us the trouble of seeking them out."

"*Ach*, the bat-planes, of course!" said the general. "They can take off when the sound-rangers hear the Allied squadrons coming. It will be easy to destroy them."

Von Zenden caught the look in Strange's eyes.

"Yes, my dear captain," he said mockingly, "it will be the end of your prize group, including the twin of that fool down below."

He had moved closer, keeping Strange covered every second. Without shifting his glance, he spoke to Karol, who had stood white-faced at one side.

"*Fraulein*, will you kindly get the manacles which *Rittmeister* Buhl has in the hall?"

Karol went out silently, returned in a moment with a pair of handcuffs. As she entered, her eyes met those of Strange for a fleeting instant. He could see the torture and misery in their dark depths. Aware of the Prussian's regard, he gave her a coldly savage look. Von Zenden laughed softly.

"Ah, so it irks the great Brain-Devil to be captured, even figuratively, by a woman. *Fraulein*, please step behind him and fasten his hands together."

Karol walked past Strange with her eyes averted. In a moment he felt the steel cuffs lock about his wrists. Von Zenden lowered his gun, quickly opened Strange's blouse and took the pistol from his armpit holster.

"*Rittmeister* Buhl," he said over his shoulder, "I am coming out with the prisoner. Be ready with your men."

There was a sound of footsteps, and as Strange was marched into the dark hall fumbling hands gripped his arms.

"Take him below," ordered von Zenden, "and lock him in a separate room from the others. Before you leave him,

rub some alcohol over his face and remove that make-up. I will take no chance on mistaken identity later on, when he is moved to Strasbourg Prison."

THE Germans hustled Strange along the black hall, down a flight of stairs, and through another dark corridor. He heard a door being opened, then there was a delay while one of the unseen men went for the alcohol. When the Boche returned, a saturated cloth was rubbed roughly across his face. Then the guards shoved him inside, and the door was closed and locked.

Strange waited a minute, then began to feel along the walls. The first one had no opening within his reach. He bumped against an iron couch as he started on. Using this to stand on, he felt along all the walls. Within a few minutes he knew there was no way of exit except by the door. A small, barred hole above the door, evidently for ventilation, offered no hope.

He sat down on the couch, the weight of despair growing stronger every moment. Finally he jumped up, turned his back to the walls, and began to tap slowly with the manacles, hoping that Noisy might be in an adjacent room and would hear him. He tried this for another five minutes, but without result. The faint echo of his tapping seemed to mock him from the darkness, and at last he gave up. He sat down again, helplessly.

There was something crushing about the absolute blackness of his prison. To force his mind from it, he attempted to twist his hands from the manacles, using the method which the Jays had taught him from their experience in vaudeville acts. But the cuffs had been specially made, with several links instead of two solid hinged sections, and they only bit tighter into his flesh.

The time dragged by. He knew that it could hardly have been an hour, but it seemed ten times that when he heard a sound at the door. He had been trying to break a piece of wire from one of the cot springs, to jimmy the handcuffs, but he jumped to his feet as he heard a key turn in the lock. He could hear the door open and close hastily. Then the beam of a flashlight probed out and fell upon him.

"Philip!" came Karol's low voice. "Good Heavens!" he whispered. "You shouldn't have come here!"

She laid down the torch, hurriedly fitted a key to the handcuffs. As they dropped from his wrists, she placed them on the couch, and by the light he saw that her hands were trembling.

"Karol!" he groaned. He swung her around, caught her in his arms. She clung to him for a moment, then suddenly drew back and looked up at him. In the glow of the flashlight, he could see the tears in her eyes.

"Oh, Philip!" she whispered. "I was afraid you thought I really tried to kill you."

He shook his head, smiled down at her.

"I didn't believe it, even then."

"It was only a strong narcotic in

the needle," she told him. "I was desperate when I found you had gone on from that French *escadrille*. One of my men had put something in your radiator at Paris, to make it leak so you would have to land. When I heard you were flying on to Chaumont, I was terrified. You will never know how glad I was when I heard your voice on the phone—even though you called me a butcher."

"My poor Karol," he said gently.

Her lips curved in a quick, sad smile.

"But I realized you were sure to be called to investigate the horrible things which had happened," she went on hurriedly. "I knew von Zenden would order the bat-pilots to attack you when he learned the other attempt had failed. I went to Hanlon Field intending to have you taken away, unconscious, to a place near Chaumont. Those agents thought you were later to be taken into Germany—but I meant only to keep you prisoner until daylight, when you would be safe."

"And now you're risking your life again for me!" he groaned. "They'll kill you if they find you here."

Her dark eyes were fixed on his face.

"It doesn't matter Philip, unless you escape." She turned, picked up the flashlight. "Bring the manacles—you may have to use them for a weapon. I could not find a gun."

"Wait," said Strange, as she moved toward the door. "I can't go unless—"

"I know—Lieutenant Jay," she said quickly. "I had already planned to release him, too."

But as she reached for the knob, he stopped her again.

"No—I refuse to let you save my life when it may mean your death. Von Zenden will surely suspect you."

Karol shook her dark head.

"He thinks I hate you—that I'm afraid of your hypnotic power. Besides, I shall be upstairs when your escape is discovered. They will probably think you picked the lock—but what they think does not matter. When we have released your comrade, you must overcome the sentry at the basement door. There is a path leading through some brush to a road close by. There is no guard on the road, and you can reach the woods at the top of the ridge. Within an hour, I will make an excuse to leave here in one of the cars, and when I meet you we can plan how you are to get across the lines."

BEFORE Strange could protest further, she switched off the torch and opened the door. He tiptoed after her. She took his hand, cautiously led him along the dark hall. In a moment she stopped and he heard the faint scrape of the key in a lock. There was a sound from within.

"Noisy!" Strange whispered, as the door opened.

He heard a hastily indrawn breath. "Phil! For the Lord's sake, how did—"

"Careful!" Strange warned him in a barely audible voice.

"The sentry is around a turn in the hall," Karol whispered, "but all of the 'bat' men have developed keen hearing, so be on your guard."

Noisy had brushed against Strange in coming out of the cell. Strange felt him start as Karol spoke.

"You must hurry," she went on anxiously. "Philip, there is only one way to handle the sentry."

"The flashlight?" he muttered.

"Yes, wait until you get to the turn in the hall, then switch it on and point it straight at him. But hold it away from you so—"

She broke off, and Strange stiffened as there came a thud of feet on stairs not far distant.

"Quick!" Karol moaned. "Some one is coming down here. I shall have to go this way, too."

Strange took the flashlight she pressed into his hand, and they hastily felt their way toward the exit. Suddenly a voice barked from the darkness ahead. The challenge was hardly half-spoken when Strange switched on the torch. The beam shot toward the turn in the corridor, fell on a burly German who had just reached that point.

The man's right hand was on a Mauser pistol at his hip, but as the light struck his eyes he threw both hands before his face and stumbled back. Strange leaped, the manacles clenched in his fist. There was a dull smack, a choked cry, and the Boche fell.

From somewhere behind, another man rasped out a Teutonic oath. Strange heard a swift scuff of feet as he whirled. A big non-com was plunging at Noisy, jerking a gun from his holster as he sprang. Noisy jumped wildly to one side as the light revealed the German. The other man swung blindly with the weapon, one hand before his eyes. Noisy stuck out his foot, and the Boche pitched headlong. The gun clattered along the stone floor.

For a second, the German clawed madly in search of the weapon, his eyes staring sightlessly. Then, as though abruptly realizing his helplessness, he opened his mouth for a shout. Strange sprang, but Noisy had already snatched the gun. The butt crunched behind the Boche's ear, and he limply sprawled on the floor.

Strange stabbed the torch beam in both directions, saw that no one was coming. He wheeled, saw Karol looking down miserably at the dead non-com.

"I'm sorry," he told her soberly, "but he'd already seen you—it's best that it happen this way."



"I know," she whispered. "I really shouldn't care. These men are not Germans any more—they've been made into beasts, and that terrible black fire—" her dark eyes suddenly lifted to his face. "I didn't know until today about that. At first the bat-planes were only used to land our agents in France, and for night observation—the pilots could see all your troop movements. . . . Please believe me, Philip. I didn't know."

"I shall always believe you," he said, and at the answering look she gave him he forgot for a moment even the danger that threatened. The color came back into Karol's pale cheeks, then she hurriedly motioned toward the basement exit.

He put down the manacles, took the fallen sentry's Mauser. With Karol and Noisy close behind, he went quickly along the hall. Just before he extinguished the flashlight he saw store-rooms on both sides, one filled with boxes of canned food, the other half filled with fuel drums and oil containers.

As they reached the exit, the rumble of an idling Mercedes reached Strange's ears. He gazed around as they emerged under the stars. They were about seventy feet from the camouflaged "hump," and through the tarpaulins and papier-mache rocks he could hear sounds of feverish activity. He turned suddenly, stared at Karol through the gloom.

"What are they doing?"

"I—oh, Philip, there's nothing you can do! You'll only be killed if—"

"So that's it!" he said grimly. "A trap for the Allied squadrons—for the rest of my pilots!"

Noisy gave a choked exclamation.

"Tom! He'll be with them! Phil, we've got to save them!"

Karol caught wildly at Strange's arm. "You can't do anything against all those men! I tried to think of a way—"

Gently but quickly, he loosened her hands. "I can't let my pilots die without trying to save them. You must get back into the house—stay there no matter what happens."

But she followed him as he ran back into the hall. He switched on the light, handed it to Noisy, rolled a gasoline drum out to the exit. Down under the rock-like camouflage, a siren gave a brief wail.

"What's that?" he asked Karol swiftly.

"The signal for the curtains at the entrance to be pulled back," she told him despairingly. "Don't you see it's too late?"

Strange whirled to Noisy.

"Get that drum open! Roll it toward the hump but let the gas spill as it goes."

He dashed back and recklessly hurled another drum onto its side, booted it toward the door. If he were to succeed, it would be a matter of seconds. Noisy had opened the first drum and was about to start it rolling when he shoved the second one outside.

"Hold it until this one's open," he said

hastily. "Let the gas be spilling down the slope."

THE plug of the second drum was tight. He hammered it with the butt of the Mauser, oblivious to the sound it made. Karol moaned as there came a chorus of exclamations from under the camouflage. Strange knocked the plug loose, spun it off with taut fingers. He was tipping the drum onto its side when a shout echoed from within the basement.

"*Gott im Himmel!* The prisoners have escaped!"

The cry was answered with an uproar from below. Strange dropped the metal tank and whirled to Karol.

"Run before they see you!"

But even as he spoke, a figure burst from the basement doorway. A light carried by some one behind him made a vague silhouette. Strange leaped in front of Karol, fired swiftly. The German crumpled in a heap.

Both fuel drums were rolling down the slope. Strange spun around, fired down at the gas-soaked ground. The spurt of flame from the gun ignited the gasoline instantly. There was a puff, a flash, and the fire streaked down the slope. Almost simultaneously, a smaller train of fire raced back toward the basement, and with a start Strange realized that one of the drums had leaked.

A shriek rose from just inside the doorway as the flame swept into the building. Strange shouted at Noisy, then seized Karol's arm and dragged the girl frantically away. There was a chorus of yells from below, then a streak of fire shot up through a hole in the camouflage, where a drum had struck.

A huge opening was visible as the blaze quickly ate its way along the canvas and papier mache. Through this hole, Strange could see at least thirty Germans milling blindly in their efforts to flee. He stopped short, shot a hasty command at Noisy.

"Get down by that path to the right! Take the Albatross—those men are blinded and no one will stop you!"

"What about you?" cried Noisy.

An explosion cut off Strange's answer. He stared around as a wave of heat swept toward them. Flame was gushing from the basement windows, and the fire had jumped to the nearby brush. With dismay, he saw that Karol's path to the road was blocked. He jerked off his blouse, put it over her head and shoulders, then lifted her in his arms and ran toward the path to the base. Flames were leaping through the brush a few yards away. He saw Noisy race by, his face turned away from the fire. Bending his head, he followed.

For a moment he thought he would never make it. The flames had almost crossed the way. But with a desperate plunge, he reached the path and turned down toward the base. The scene which met his eyes was like the painting of some mad artist.

Both of the gas drums had burst and scattered blazing gasoline over one side of the canyon. Three of the weird bat-ships were on fire, their webbed wings seeming to flutter madly in the blaze.

Pilots and ground men, completely blinded, were dashing back and forth, falling over each other, bumping into everything in their way. He could hear their screams of panic above the roar of the flames.

Two bat-planes had been pushed out to the entrance, in take-off position. The first was slowly moving ahead, as the German at the controls sought to taxi away from the dazzling glare. Back of the second bat-ship was the Albatross. Noisy was half-way to it when a man in olive-drab raced from the other side of a bat-plane and vaulted into the Albatross' pit.

Noisy fired. The man swiftly pivoted, and Strange saw the face of von Zenden. The Prussian pumped two shots toward Noisy, then whirled back to the controls and sent the Albatross rolling around the bat-plane and into the canyon.

Strange looked desperately about him, then ran to the D.H. in which he and Noisy had flown. Karol pushed the blouse away from her face as he put her down. A look of horror came into her eyes at the mad scene before her. He helped her up into the rear pit, sprang onto the wing and reached into the front cockpit to set the switch and throttle.

Before he could jump down to get Noisy, he saw the Jay twin at the prop. Noisy pulled the heavy blade through, lunged again as the Liberty failed to start. This time the engine caught with a sputter.

A sudden blast of air from the entrance sent the flames to billowing wildly. The first bat pilot was attempting to take off, and the second black ship was slowly edging away from the glare. Strange swore savagely. Even one of those devils would be enough to destroy a squadron.

"Let her go!" Noisy yelled, as he dashed back and leaped to the step. "I'll ride the wing!"

STRANGE threw himself down at the controls. A staggering bat-pilot almost reeled into his path as he sent the two-seater forward. Scorching heat surged out from the side of the base. He motioned Karol down low, crouched over the stick. The D.H. gained speed, shot out into the cooler air of the canyon. The second bat-ship was now out of the brighter zone. As the two-seater bore down on it, the sinister black raider lurched crazily and piled headlong into the rocks.

With a violent kick, Strange swerved the D.H. past the wreck and on into the canyon. As the two-seater soared up between the rocky walls he saw the other bat-plane. It was perilously close to the left-hand side of the canyon, but the pilot was flying straight ahead. Strange grimly squeezed the stick trigger, and a white tracer streak shot toward the German craft.

Like a thunderbolt, von Zenden's Albatross came hurtling to the rescue. Strange turned cold as he saw the red eyes of the Spandaus and thought of his precious cargo. With an almost superhuman skill, he reversed in the nar-

row canyon. There was one frightful instant when they seemed destined to crash straight into the ridge. Then the dark, jagged rocks swept underneath.

Before the Prussian could pull up from his dive, Strange was on his tail. Von Zenden rolled madly to the left as the Vickers probed for his back. Suddenly a brilliant light shone out almost overhead, and a parachute flare added its radiance to the lurid glow beneath. Von Zenden plunged downwind at terrific speed, as a score of Spads and Nieupoorts dropped out of the night.

Strange had banked quickly as the flare lit up. He leveled out half a mile away and gazed across the sky. Of the Prussian there was no sign. Once again, the Man of a Thousand Faces had escaped by a miracle. But the last bat-ship was doomed. Strange saw it twisting and turning, like some huge night-bird trapped in the mid-day sun. A shiver ran over him as he thought of the now utterly blinded pilot, waiting for death in a horror of helplessness. Then he remembered the blackened bodies which had lain on Hanlon Field.

Without emotion, he saw the Allied ships close in. There was a muffled rattle of guns, then the last of the deadly bats went fluttering down to the flaming canyon beneath

THE sky was beginning to gray when the D.H. rolled to a stop in a meadow near the little Boche village of Weille. A minute later, two figures stood under a tree near the idling ship.

"Are you sure," Strange said anxiously, "that von Zenden did not see you?"

Karol slowly nodded.

"I bent over—and it was almost dark. Don't fear for me—I shall say I escaped by the road"

Her voice trailed off, then she looked up with a wistful smile.

"Perhaps, some day, we shall not have to lie. I am so tired of lying, Philip—so tired of war—"

He smiled down gravely at her.

"It will end some day, and then—reunion in old Mecklenburg—perhaps it will be June—"

"Then you have not forgotten?" she whispered.

"I shall never forget." He raised her hands to his lips. "Goodbye, my Karol."

She looked up through sudden tears.

"*Auf Wiedersehen*, dear enemy—go quickly, while I still can smile."

And moments later, as the ship roared up into the West, he still seemed to hear that beloved voice "*Auf Wiedersehen*, dear enemy—go quickly, while I still can smile."

All Questions Answered

(Continued from page 27)

We try and try to put this over. If you want us to guess at them, all right, but we do not know. And we cannot give out information on the nicknames of ships. If you want such information, tell us what ship you are talking about by its

correct type number. There are about forty types of Hawks, remember.

Harold Buck, Columbus, Ga.:—The Heath plane we mentioned is now made by the International Aircraft Corporation of Niles, Mich. The planes put out by this firm may be purchased outright ready to fly, or they may be bought in knock-down kits to be assembled at home. Please write to the firm and get the complete details and prices. That's all we can tell you.

Grant P. Lindmark, Bellaire, L. I.:—In the case of the dirigible, as in the stratosphere balloon, it has its "pressure height" or the utmost height the gas in its cells will lift the load carried, but with the use of elevators and propellers, the airship can operate at altitudes substantially below this height without any change of "lift" since as the ship descends, the surrounding air being denser compresses the gas in the cells automatically. But if it exceeds this height it must lose gas and a new "pressure height" is established. It is clear, then, that the higher an airship flies the less becomes its useful lift as the gross lift of the gas is less by the amount that has to be allowed to escape through the automatic valves to stabilize the new "pressure height" at the higher level.

The control of an airship is handled in two ways. Minor alterations in height are made by the elevators and large alterations by releasing ballast or gas. The action of the elevators is dynamic and can only be used when the ship is moving. Once the airship is brought up to the desired cruising height, minor changes in altitude can then be made with the elevators.

Bob Yuncher, Loudenville:—I do not know where you could purchase a new or second-hand compressed air motor. I would advise you to consult the model plane advertisements and barter columns in this and other aviation magazines. I do not know anything about the other motor you mentioned.

A. C. Pennells, Toronto:—The Heath is not a two-seater and we know of no other plane in that class that could be purchased and built in the same way. You might try the Universal Aircraft Company, Dept. 6, Fort Worth, Texas, and see what they have in that line. They advertise in this magazine.

Arnold Johnson, Everett, Wash.:—It would be impossible to say whether the rear propeller on the Macchi-Castoldi racer engine gives out more or less "pull" than the front one. I know of no

way in which the problem could be tackled, and I do not believe the Italian designers know either. However, your point is very interesting and perhaps some of our mathematically inclined readers can work it out. The propellers turn at the same speed. I can understand your interest in the problem.

Thomas Dunn, Brooklyn:—Your plans for a stratosphere plane are interesting, but I am not qualified to state whether the plane would be a success or not. Besides your drawing is not quite clear.

R. W. Richardson, Aurora, Ill.:—You are right, we pulled a boner. The Eagle of Lille was Max Immelman and not Werner Voss. We hope the others who questioned the answer will read this, too, and see that we have been properly checked up. Is our face red?

D. Kirkland, Natal, South Africa:—Anhedral is just the opposite of dihedral. In dihedral the wing tips turn *upward*. In the anhedral form of design the wing tips turn *down*.

Dick Schwab, New York City:—While no official figures have been given out, we believe the new Hawker fighter monoplane is now the fastest single-seater in the world. It does well over 300 m.p.h. We cannot give out the speeds of ships in service or under consideration for service squadrons, as they are not given out officially until they have been in squadron service about two years.

Alex Robertson, Vancouver, B. C., Canada:—You are not going to get us into that Allmenroeder scrap. No one seems to know who killed the famous German ace, but we, too, always believed that Ray Collishaw shot him down. In the last few years we have heard so many stories on that scrap that we have given up. I have read the book you mention about ten times, and can repeat chapters of it by heart.

Wiley Stanford, Norfolk, Va.:—The reason seaplanes seem to have the edge in speed is that as a racing plane they can be designed with such a small wing, and still get down with a reasonable amount of safety, whereas, in the land plane the designer must consider the landing speed and the comparative small areas of a ground landing space. The Macchi, for instance, probably lands at about 180 on water, and it is reasonable to see that no land plane could be put down on a field at that speed. So you see, it is not the fact that it is a seaplane, but that it can be landed at high speeds. Perhaps some smart

land-plane designer can overcome this problem and bring the speed mark back to the land planes.

L. J. Hellenburg, Bronx, N. Y.:—We would be interested in the pictures you mention. I do not know of any Forest Rangers Air Corps. I have no record of a German ace by the name of Strauss.

Theodore O. Hulse, Westhampton Beach, L. I.:—The planes of McCudden, Brown, and Springs were not painted any differently than the others in their outfit. Once McCudden had a red spinner on his prop, but that was a far as he went. Quentin Roosevelt's Nieuport was simply silver like the rest with ordinary markings on it. The names given to Ray Collishaw's black triplane was "Black Maria." The others were "Black Death," "Black Roger," "Black Sheep," and "Black Prince." You do go for this stuff, don't you!

Carl Stuebner, South Ozone Park, L. I.:—The details of the gun you mention are correct as far as I know, but there is nothing particularly new about it. See my comment in Happy Landings. The Congressional Medal of Honor is an active service award given to both officers and enlisted men. No one can win it in peace time. It is a war medal.

James W. Murphy, Halifax, N. S.:—I would not care to attempt to list the ten foremost American pilots of today. That would be simply leaving myself open to considerable criticism, and I get enough of that sort of thing, as it is. Major A. D. Carter with 31 victories came from Pointe de Bute, N. B. J. M. Millet with 4 Huns came from Windsor, N. S., but he was killed in action. And W. G. Ivamy of New Westminster, B. C., is credited with 3 victories.

William B. Jackson, Vancouver, B.C.:—I'm sorry, but I do not know how you can overcome the Canadian customs business in purchasing a gas-job motor in this country. You might try England, however, and I recommend the Model Aircraft Stores, 133 Richmond Park Road, Bournemouth, England, where they handle the 18 cc. Comet engine. I have no list of Canadian model supply houses. Perhaps some of our Canadian friends can help us out.

Edward Cottinsham, Bronx, New York:—The Fairey Fantome was built by the Fairey Aviation Works of Hayes, Middlesex, England. Their latest single-seater is the new Fairey Monofox which has a top speed of 236 m.p.h. and climbs to 19,000 feet in eight minutes.

—ARCH WHITEHOUSE.

From the Model Builder's Workbench

(Continued from page 46)

dislodge the paper straws while carving and sanding. This process provides a more uniform job and neatness.

For smaller portholes, the straws can be unrolled and then rerolled to fit. The

kind of straws made for malted milk may be used for slightly larger models.

A single flashlight cell supplies the "juice" for the bulb inside the body, the battery being concealed in a cigar

box upon which the whole plane is mounted. The connecting wires are run up through the box and the bottom of the plane's hull to the bulb. A switch on the side of the box operates the

electricity. The box is then painted, the top representing the sea upon which the plane is sitting.

Rhinestone buttons make convincing landing lights when set in an aperture $\frac{1}{4}$ " square and $\frac{1}{8}$ " deep cut in the landing edge of the wing. A covering of mica is then placed over the "lights," following the curve of the airfoil and lying flush on all edges with the wood.

Here are a few miscellaneous suggestions:

The use of a medicine dropper for thinner. This prevents wasting the solution when diluting dope.

Exhaust stacks and control horns can be made from aluminum wire.

Do not use acetone instead of thinner in dope, as it dries streaked. Banana oil, however, is satisfactory.

Several pairs of tweezers (of different sizes) will save much time and trouble in your work.

Always keep your tools sharp—and free of dope and cement.

A small vise is convenient for bending or holding piano wire, etc.

Keep your razor blades in a tin aspirin box.

—MARION FERGUSON.

CAMOUFLAGE

A PROBLEM that has long confronted model builders is that of making camouflaged tissue which looks realistic. Here is a simple way of painting good camouflage before mounting the tissue.

Lay the tissue on wax paper and dampen it slightly with a rag that has almost dried. Using water colors of the variety desired, cover the paper with spots which almost, but not quite, touch. They will then run together a little, giving the mottled appearance of true camouflaged tissue. Brown and yellow with touches of purple blend the best—in fact these hues are approved by the Air Corps.

Allow the tissue to dry thoroughly on the wax paper, then peel it off. Lay it back again on the wax paper and iron out the wrinkles, pulling the paper off as you finish ironing. This is to prevent the wax from drying and holding the tissue.

After the paper is mounted on your ship, plain dope will shrink it.

—THOMAS MCGARRY & GLEN TASSIE.

WINDOW SHADE HINTS

1—When planning a gas-model, the builder is confronted with the problem of obtaining paper large enough for his plans. I have found that a white window shade makes an excellent plan sheet. It is sufficiently long and is not so apt to tear as paper. The roller should be left on the shade, as this will keep your plan in good shape. The thin stick at the end should be left on, too, as nails may be put through this to fasten the plan to the bench.

2—Again the shade comes into action. Many model builders often take pictures of their models without thought of a realistic background. Take the shade and lightly sketch on it a background—a few hangers, crash-truck, etc. Then use your model paints to fill in these sketches. A few clouds may be added to make it even more realistic. Now poise your ship in front of this scene and "shoot." (You may also construct a foreground, as explained in the article on page 39 of your November FLYING ACES, which will make the scene even more realistic.)

—C. J. O'NEILL, JR.

Modern Planes Album

(Continued from page 53)

tion of her real cruising speed, for the distance broke the world's non-stop flying-boat record of 3,063,168 miles made by an Italian patrol boat last July.

It is understood that more than fifty of these boats have been or-

dered by the government for Naval patrol work. It has a wing span of 104 feet, an overall length of 63 feet, and a height of 17 feet. We have no details of her military equipment.

Most of these new patrol boats will be stationed at Pearl Harbor, Hawaii,

from where they will be called upon to cover the vast area surrounding our most important Pacific possession.

(See page 53 of your May FLYING ACES for model plans of this great flying boat.)

Sky Gun Snare

(Continued from page 22)

Sure enough, it was the voice he had been expecting—his old stumbling block, that ever-present enigma of human cusdedness that had dogged his footsteps for years. Drury Lang, the bloodhound of the D. of J.

"Of course it's me. That's who you called, isn't it. Or do you have a wrong number?"

"Shut up, you! I'm going to fit you for a suit of prison denim this time sure, Mister Kerry Keen."

"Whatever it is, I did it," Keen agreed with a smile in his voice.

"You bet you did. Come down here right away—and bring all your best alibis with you. You're going to need them! Where were you last night between ten and midnight? Now don't pull that old theater program gag on me again."

"I'll be down in three ticks," Keen jabbered back into the receiver.

"And you can bring that Grice gun with you. It will save a lot of time and trouble," Drury Lang barked.

"The what?" Keen gulped.

"Go on. Get into your duds. You won't be wearing them much longer. You get down here fast."

"They worked fast," agreed Keen as he leaped for his bathroom. "Oh, well, it had to come sooner or later."

THE downtown office of John Scott was hidden away in a musty building that catered to the suit and cloak trade. Actually it was the New York office of the Division of Investigation, but the sign on the door indicated that the occupant was the local agent for a stringy line of ready-to-wear apparel.

Kerry Keen, young man about town and ballistics expert of considerable note, walked in togged out in a quiet blue suit, black walking shoes, and swinging a blackthorn stick. He sat down in a rickety chair, clamped his heels over the front rung of the chair, and sat gnawing at the polished end of his cane.

John Scott, the stocky, amiable government sleuth eyed him for several moments without saying a word. Keen returned the stare, then began drawing designs on the floor with the ferrule of his stick.

"Well?" Scott asked.

"Between ten and twelve last night I was coming down Long Island sound from New London. My friend, who owns the cruiser, dropped me off at the Wall Street ramp and went on around to the Elco Boat Works at Bayonne. He wanted some job done on his boat, I believe."

"Wall Street ramp, Keen?" snarled Lang. "You didn't, by any chance, come down the Sound in a seaplane . . . er, flying boat, did you?"

"Good Lord, no! At night? Into all that traffic?" Keen queried aghast.

John Scott tried to fathom Keen. He certainly was putting on a grand dumb show.

"You know you're a liar, Keen," Drury Lang barked, "but it won't work this time. We don't care where you were. Hand over that gun!"

Keen sat up astonished. "What are you talking about?" he said.

"The Grice Flexthud gun, Keen. Taken last night from John Grice's little factory at Stratford. You know all about it."

At this point John Scott broke in again:

"What he's trying to say, Keen, is that someone has taken an important new weapon from a very clever inventor. The U. S. Army Ordnance Department officials want that gun, Keen. It's different this time. Someone has lifted something that is practically government property."

"So what?" said Keen.

"You know all about it," Lang burst out again.

"He means," Scott added, "that you ordered some special ammunition from the Packert Ammunition Plant—ammunition that would fit that gun. I believe it was a certain 40 mm. size. Anyhow you ordered 1,000 rounds of it."

"So I'm not the Griffon this time, eh?" Keen said quietly.

"We're not sure, yet," Lang spat.

"This is serious, Keen," Scott broke in again with a pained air. It was plain he did not relish this interview. "You *did* order that ammunition to those specifications, didn't you, Keen?"

Keen hesitated, frowned at the diagram he had drawn on the floor.

"How do you know this gun was stolen—taken last night?" he finally asked.

"John Grice and his gun have both disappeared. He was supposed to exhibit it tomorrow before a select crowd of Army officials. The ammunition has disappeared, too!"

"What?" Keen said hastily. "I say!"

Then he seemed to recover and take a new tack. "I mean. How did all this become known?"

Both Lang and Scott seemed uncertain what to answer.

"I presume," taunted Keen, "you suddenly decided to go out to Stratford and look the old inventor up for no reason—and then found he was missing."

"No. You see, Keen," Scott explained, "A man named Renklund—he owns the factory building Grice was using—was worried about Grice not paying his rent. He tipped us off last night. Told us that something has happened out there—that Grice and his gun were missing."

"What time did he—Renklund—call you?"

"About midnight. Maybe a little after."

Keen sucked the end of his stick reflectively. "How did this man Renklund know Grice had a new invention up there?"

"I don't know. But I presumed he knew what Grice was up to, or he wouldn't have rented him the factory."

"Where did he call from?"

Both Lang and Scott stared at the report on the desk. "He never said," replied Scott. "We were too interested in the details he gave us."

"And don't stall, Keen," Lang growled. "Where's that gun? You got the ammunition from Packerts. You must have the gun!"

"As sure as I sit here, John," Keen said, "you are both wrong. I have neither the gun nor the ammunition."

Scott was still trying to figure Keen out. "You ordered that ammunition, Keen," he said accusingly.

"I never said I didn't," Keen answered sullenly.

"Well, where is it?"

"I don't know. If someone went to Packert's and took it, I'm as much in the dark as you."

"They said you called for it yourself—personally."

Keen shook his head. He reflected that a forged check supposedly signed by himself had given him the first intimation that the Flexthud gun ammunition had gone astray.

"And why did you order ammunition of that size?"

"That I can't tell you now, John. Not just now."

"You're putting us in a tough spot."

"I can understand that, but you will have to believe me."

"That gun—and John Grice—were to be on exhibition tomorrow at Ramshead Island—off Nantucket. And this is Tuesday. That's practically an Army order, Keen."

But Kerry Keen was thinking about the man named Renklund who had called Scott at 12 o'clock the night before.

That Sikorsky had hit the water at 11:10.

"WHAT'S all this flying boat business, Lang?" Keen suddenly asked.

"Nothing much, except that a two-engined flying boat crashed in the Sound off Saybrook Point last night. It appears to have been shot down, somehow. The Coast Guard men are pulling it out with the aid of a hoisting tug from New London."

"But what has that to do with the Grice gun business?"

Scott and Lang again exchanged queer glances and Keen knew he was in for something startling. They were about to play their trump card.

"Oh nothing—except that the body of John Grice was found on board the wreckage of that flying boat. And a Griffon card was stuck in the compass correction-card bracket!"

Keen could hardly believe his ears: "John Grice dead? Are you sure?"

"As sure as you can figure from what is left after such a crash. The body looks like him, is dressed like him, and had articles of identification in his pockets that indicated it *was* him. What more do you want?"

"It doesn't make sense," Keen argued, lighting a cigarette.

"What doesn't?" Lang spluttered.

"I mean . . . golly, I don't know what I mean. But how could this man Grice get aboard that flying boat and what was he doing there?"

"You tell us. You hooked the ammunition for his gun, and what the hell would you want with it—without the gun?"

"It does *sound* silly, doesn't it?"

"You'll *look* silly, too, behind bars, Keen," Lang threatened.

"The gun is no good without the ammunition, is it?" Keen grinned.

"And the ammunition is no good without the gun. That adds up to one thing, Keen," Lang said with a threatening tone.

"I'm supposed to get the gun and the ammunition and have it all—plus John Grice, who must be resurrected from the dead—at Ramshead Island by noon tomorrow. Quite an assignment, Lang."

"That'll be in daylight, too, Keen. No phony night flying stuff, dropped out of the clouds, either," Lang scowled.

"You amaze me, Lang," Keen smiled. "You really think I can do all that, don't you?"

"That gun had better be at Ramshead

Island tomorrow at noon, or you go into stir for the rest of your natural."

"Just let me see that report you so innocently took from one Mr. Renklund, Lang. That must be a daisy."

They handed him the report and Keen studied it for several minutes. Then he got up, tossed it back on the table, and with a hearty laugh strode for the door.

"I'll see you tomorrow at Ramshead Island, Lang. And by the by, where can I get a pulmotor and a bucket of adrenalin?"

"What do you want that stuff for?"

"We might be able to save you yet, Lang," Keen laughed again and sauntered out.

"Now what the hell did he mean by that," Drury Lang said, snatching at the report.

THAT night the Black Bullet amphibian was trundled out of her hidden hangar again and rolled gently down to the water. It was well after 10 o'clock before Keen, dressed in his black outfit, dared take a chance; for the days were long and he had many things to consider if he was going to satisfy John Scott and Drury Lang.

Barney O'Dare his Pulski under certain circumstances, ran back and worked the mechanism that closed the false rockery. Then he came back and climbed in, muttering under his breath.

"Shut up," barked Keen, speaking normally now, and not into the hidden mouthpiece set in the chin-pad of his helmet which disguised his voice by directing his speech out of a small microphone fitted into the collar of his coverall. "You've had nothing to do all day but guzzle Duggan's Dew and see that old Grice was Okay. By the way, does he suspect anything yet?"

"He actually thinks he's somewhere on Block Island—at a joint this bird Renklund owns. You sure have him fooled," Barney added as Keen let the Avia out and shot the Black Bullet into the starry sky above.

"And they've fooled me plenty, so far," Keen said once they were at a reasonable height. "This guy Ranklund had someone who was a damned smart impersonator. He impersonated me up at the Packert plant and actually got them to turn that case of special ammunition over to him. Then he impersonated Grice. But he went west in that crash last night."

"The whole thing is screwy. But where is Renklund and the gun?" Barney demanded.

"And the ammunition," added Keen.

"Why did you put in that order at Packert's?" Barney asked suddenly.

"Old Grice asked me to," replied Keen, "He had no more dough. And since I had credit with the Packert people, I ordered it for him."

"Now you capture him, stick him away, and he doesn't even recognize you. This is a pip!"

"It's a good thing I did. He'd be a dead man by now."

"Well, what is it? Stratford again, or Block Island?" Barney asked.

"I'm trying to decide. Wait until I

get the cobwebs swept out of my noggin, Barney. Grice thinks Renklund has a place at Block Island, and I have a hunch Renklund will try to go back to Grice's place at Stratford. He could use those blueprints, too, you know."

"Hey look!" Barney suddenly cried. "See down there. Coming out toward the Montauk light?"

THADDEUS RENKLUND was a short, hairy man who might have passed for the conductor of a fourth-rate symphony orchestra. He had wide splayed legs and small feet encased in rich, French-kid shoes that had no toe-cap. He was massive of paunch, but he walked with a certain grace in spite of his weight. His lips were colorless and huge, reminding one of two sausages laid one above the other. Though his hands were somewhat pudgy, they were extremely eloquent when he spoke.

Thaddeus Renklund was successful, in his line, but while he had just accomplished the greatest *coup* of his career, it was obvious that something was bothering him, draining every ounce of satisfaction out of him.

He sat before a massive, field-stone fireplace in which burned a pile of crackling logs. It was summer on the calendar, but the night was cool and the breeze from the Atlantic added a tingle to the air.

Renklund was not alone. Two other men sat opposite, staring into the fire. Two more lounged at a long refectory table, smoking generous bowled pipes. It might have been a scene laid in a comfortable country home—except for the strange drawn tenseness that seemed to charge the atmosphere.

"You are a fool, Renklund," the lean man at the table snapped. "The risk is too great."

He was an impressive figure, slim and well dressed. Only a scar that drew up one corner of his left eye hinted at the cruelty that lay in that wiry frame. He was Eric Holmbein, gentleman adventurer and international crook—fine horseman, a crack sailor, and a pilot who had had plenty of experience flying the Aktiebolaget Aerotransport night mail between Malmo, Copenhagen, and Hanover. His employers had found a slit registered mail pouch. That had been his undoing.

"I do not see what you have to gain, Renklund," a third said moodily—a man with a slight accent, a good profile, a monocle, and small moustache. He was Lars Angstrom.

The pudgy Renklund shoved himself away from the great mantlepiece, stared around authoritatively.

"We have the gun, yes," he sputtered through his ratty whiskers. "We have the ammunition, too. But we failed to get the blueprints."

"All the more reason to move fast out of here, and smuggle that gun aboard the *Skaggholm*. I do not trust that man, Keen," Angstrom argued, fingering his jeweled cigarette holder.

"The *Skaggholm* is at Pier 24, North River, on the Hoboken side," Renklund snapped. "We are on Block Island, nearly 150 miles away. We must go through

Long Island Sound or around Long Island on the ocean side. That swine, Keen, is holed up somewhere near East Hampton—a place called Grass . . . Grayfields, or something like that. Anyhow, I know where the place is, and I'm going to get him—before he gets us. I'm going there and clean him out. I'm certain he has Grice there, too, and that would be a clean job, getting both of them. Anyway, I won't feel safe until we do.

"How are you going to do it?" Angstrom asked.

"We have the Dornier seaplane yet," Renklund argued.

"You're surely not risking that," Holmbein broke in. "Suppose something goes wrong? You'd be left high and dry with an unlicensed foreign military ship to account for—and you still



haven't put the gun aboard the *Skaggholm*. I'm not flying the Dornier on any fool's errand now."

"Since when, may I ask," Renklund asked, his eyes flaming, "are you giving orders?"

"I'm the pilot," the tall man argued. "You did Wahrgren in on that Sikorsky the other night, but you're not going to send me on any such game!"

Renklund's eyes flared, and he leaped at Holmbein, gun drawn. But he was not fast enough. The dapper Angstrom hurtled across the room like a panther, and though Renklund's gun went off, the bullet only went through the floor. Renklund, raging, replaced his weapon in its holster.

Holmbein was white as he gave Angstrom a pathetic glance of gratitude. He knew that he had been close to death.

"All right, Renklund," he then said in a low voice. "You're the boss!"

"Yes, and don't ever forget it," cracked Thaddeus Renklund. "True I sent Wahrgren to his death," he added, "but it was for a good cause. Nordquist went, too, and so did Dubendorf. It was too bad, but it had to happen—and while that swine, Keen, is alive, there's a big chance we may get the same dose. It's 150 miles to Hoboken, remember, and anything can happen on the way."

"The *Skaggholm* sails at noon, Thursday, doesn't she?" asked one of the other men.

"Yes, and Grice is supposed to be at Ramshead Island at noon, tomorrow. And now, what kind of a bomb must we fit in the Dornier crutch rack?" snapped Renklund.

"I think we can use that 1,000-pound torpedo for demolition purposes," Holmbein answered with a scowl.

"Perfect! Have her mounted and get ready to leave the minute it gets dark. We'll get that devil, Keen, if it's the last thing we do."

Two of the lesser lights followed the pilot out. They had the earmarks of professional mechanics.

"Are you going, Renklund?" Lars

Angstrom asked his boss, casually. "No—and neither are you, Angstrom," Renklund replied. "Holmbein can do that little job himself—that is, with Bernt as gunner."

"I see . . . just in case, eh?" Angstrom said quietly, staring into the fire. "Just in case," smiled Renklund.

"**W**HAT the deuce is that?" Kerry Keen snapped, peering out of the covered cockpit of the Black Bullet.

A trim-winged silver monoplane fitted with twin-floats and a long water-cooled engine lifted clear of the blue-black water below and began a long graceful climb. Keen shut his mufflers, circled quietly above.

"No markings or license numbers," muttered Barney.

"Do you feel anything, Barney?" Keen asked.

"I feel like a drink."

"No, I mean do you feel something funny running up and down your spine?"

"No. I took a bath yesterday."

"Never mind, skip it. But watch that baby. I have a feeling something is going to happen."

They held their altitude, watched the silver monoplane curl around again.

"Hey, wait a minute," barked Barney. "I 'feel' something now! Look at that thing between her pontoons."

"Belly tanks?" asked Keen.

"No a full-fledged torpedo!"

"To demolish things with—and we'll soon find out what," smiled Keen.

"I'm afraid we will. Look, there he goes heading across for the Light!"

"Either the Light, Grice's place at Stratford . . . or," whispered Keen to himself. Then aloud: "What the devil sort of plane is it, anyway? Looks like that new Dornier torpedo-bomber. She's a beaut."

"Something tells me we are in for it," sang Barney at the top of his voice. "They didn't sail that kite just to look at Montauk."

"Right! Load everything you've got."

They stayed well above the silver monoplane, watched it head toward the light. It had climbed to about 4,000 feet now and was turning again to face the ocean. Keen was puzzled, wondered what the game was.

Suddenly, the strange craft turned and shot toward the southeast shore of Long Island. Keen acted accordingly. He nosed down tore after her. Something told him that monoplane was heading for Graylands, and he didn't like the look of it.

The silver monoplane nosed down and Keen set the Black Bullet after her. He realized now, what the game was. The Dornier was heading straight for Graylands!

"Good Lord! Grice is in there, helpless!" he muttered, loading his heavy Darn guns.

The silver monoplane was now curving back and forth to get the wind angle. Keen sensed that the pilot knew his business and was taking no chances. The Black Bullet took the bit in her teeth when Keen yanked the Skodas out and he flashed after the silver Dor-

nier, dived, and sprayed it with lead. The pilot tried to shake the black Phantom off. But he still roared toward the rambling brownstone building below.

Keen now threw all caution to the winds. He could see the observer bending over the bomb-sight set in the cockpit. Barney opened fire over the side, made the Dornier swerve. Keen slammed at her from a tight angle and blew a long burst from four front guns.

The Dornier staggered, twisted in agony, and rolled away. Keen waited to see the demolition bomb spin out and hurtle toward the sandy beach below.

But nothing of the kind happened! The Dornier twisted smartly in skilled hands and darted away. And now the gunner opened fire and made Keen zoom clear while Barney engaged the other ship at long range.

"I'm going after him," yelled Keen. "We'll find out what the game is."

He trimmed the tail for climbing and shot up the sky like a black rocket. Barney wanted to keep blasting, but Keen barked at him to hold off.

"We'll clear him in a minute and he'll never know where we went. Watch him closely."

The Dornier was streaking back toward Block Island at fully 160 and Keen tingled at the thrill of the strange chase.

"Look! Look!" screamed Barney. "He's nosing down at that cruiser down there."

"Where?" asked Keen.

"That long cabin-cruiser coming down past that line of buoys. A swanky private job."

"Oh, I thought you meant a *Navy cruiser*. I see. Sure, he's recognized it. He's circling, blowing signal lights. Look!"

They watched the silver Dornier for several moments from their secret post high in the sky where the Skoda mufflers cut down all sound of the Avia. The silver ship seemed to curl tighter and tighter as if it would get down and halt the cabin cruiser.

"Get it?" bellowed Barney. "They're making a contact."

"So are we!" added Keen, and he put the Black Bullet in a screaming dive. He could see the smart cabin-cruiser zipping through the rollers that swelled out from the north-east. It seemed to be attempting to get away from the silver monoplane, which was now circling ominously over it.

"He's going to bomb it!" Barney yelled.

A strange fear swept through Keen. Of course, there was no particular reason why he should worry about the cruiser being bombed—yet something inside him told him that cruiser must not go down.

Like a rocket, the Black Bullet slammed at the silver monoplane, made the pilot hoik up. But no shots were fired in return and Keen was amazed to see that the Dornier pilot paid no further attention to his charges. He was peering over the side, flying automatically, and firing pistol-signals down at the cruiser.

"He wants him to stop for some reason," Barney barked.

"Watch him—and his gunner. There's something queer going on."

"He's going to land near the cruiser," hollered Barney.

Keen pulled up again, circled at about 800 feet. They could see the Dornier slamming her pontoons through the rollers and running up toward the cabin ship.

"There must be something important down there, to risk a contact under conditions like this," Keen mused. "What the devil is it?"

They saw the Dornier edge up to the cruiser and ease its slim pontoons against the hull of the boat. A boathook steadied them and for several seconds there was a general wrangling going on between the crew of the Dornier and the men in the aft-well of the cruiser.

"I'm going down, too," Keen said, watching the proceedings with puzzled interest.

ERIC HOLMBEIN knew what was happening the minute he spotted that cabin cruiser. It was Renklund's boat, and so he sensed treachery at once.

"You see," he barked at his gunner, "they sent us out to bomb that place and then tried to skip through with the gun under cover of the excitement. That Renklund is the lowest of rats!"

"Are we putting up with that?" the young observer said into his tube.

"Not likely! If he's heading for Hoboken and the *Skaggholm*, he's not leaving me to get rid of this plane. We're going down and go aboard, too, Wetzel."

"But that black swine up there! What about him?"

"We'll have to risk him. You try to hold him off while I head Renklund off. I'm not being left with a prison term on my hands."

He nosed down, brought the Dornier into the waves and ran alongside.

"Where have you been?" Renklund bellowed through his cupped hands "You're still carrying the torpedo!"

"I know. But that black plane drove us off. Where are you going?"

"I'm clearing off. Things are too hot in this section. You return to Block Island and wait until you hear from me. Beat it, before a Coast Guard cutter spots us."

"Not me, Renklund," Holmbein snarled. "You're heading for the *Skaggholm*—and I'm going with you, I'm not going to be left as bait in the trap."

"You damn fool! Don't you realize that man, Keen, knows who you are and who I am? You've got to get rid of him or he'll spot the lot of us. That's why I sent you down to get him first."

"I don't know who it is up there. But I'm not staying with this machine. I say we should plug holes in the pontoons

and let her sink. I'm coming aboard!"

"You are not! You'll stay up there and drive that black devil off until we can get clear!" Renklund shouted. "Get back into the air! This gun has got to be in the Syndicate's hands within ten days or we don't get a penny."

"I'm not taking any chances with that man up there. He has too many guns."

"We've one down here he'd like," crackled Renklund. "Now get up there and draw him away—at least."

But Holmbein was already crawling out of his cockpit. Renklund let out a cruel oath, reached for a gun. Again Lars Angstrom tried to interfere, but his move was his last. From the back seat of the Dornier, a terrible burst of fire crashed out from the observer's gun and both Renklund and the dapper Angstrom went down in a welter of blood.

"Wetzel!" screamed Holmbein. "What have you done?"

"He had it coming to him. He would have finished you. And where would I be?"

The cabin-cruiser continued to bob in the swells.

Holmbein was standing on the pontoon holding the stress tubes. For a moment, he seemed uncertain what to do. But then, out of the sky came his black nemesis again. With a lunge he was back in the cockpit fumbling for the throttle. He gave the big Hispano-Suiza the gun and raced away, leaving the cruiser with two dead men in the open well.

KERRY KEEN had seen the shots.

He charged after the Dornier, but on second thought, wheeled back and went down to investigate the cruiser. He planted the floats of the Black Bullet down on the water and eased up, just as the Dornier had done. Turning the controls over to Barney he went over, slipped off the wing, and dropped into the well.

He saw what had happened in one glance.

He then swung inside and spotted several wooden cases. They were marked "Packert Arms and Ammunition Corporation." Keen knew at once what was in those cases. The ammunition for the Grice Flexthud gun!

He also caught sight of a burlap bundle. He dragged it out, felt it carefully. Then he snatched a card from his pocket, scribbled on it, and slipped it under one of the metal straps of the first ammunition box. Finally, he hoisted the burlap bundle to his shoulder and climbed on deck.

At the wheel he stopped and hurriedly ran up two red lanterns, the forward lantern being set a few feet lower than the one hung in line with it from the stub mast. Then he switched off the engine and heaved the sea anchor overboard.

"Come on! Come on!" Barney was yelling. "We got company on the way!"

Keen climbed aboard the Black Bullet, shoved the bundle in to Barney. He could hear the throb of a heavy Diesel somewhere, and suddenly a shot boomed out across the bow of the cruiser and



threw up a tall plume of water a few yards beyond.

"Beat it, Barney," Keen yelled. "Get out of here. I hung a 'craft not under command' signal up. They'll come and take her over. Beat it!"

The Black Bullet shot away in spite of the heavy fire from a Coast Guard cutter's one-pounder. Barney sent her well out to sea first, then gradually eased back on his mufflers, brought her through, and rolled up the sandy beach toward the hidden hangar.

"Well, Barney," laughed Keen, once they were inside and all snug again. "We've got the gun and the Coast Guard lads *should* have the ammunition by now."

"And all you have to do is to get old Grice and his gun up to Ramshead Island by noon tomorrow, without anyone knowing how you got it or who kidnapped the old devil, eh?"

"That's all," smiled Keen grimly. "Now I've got to skid back to the city to hold Drury Lang off, or he'll be around asking too many questions that are too hard to answer. See that Grice is taken care of, and don't let anyone even *look* at the gun here."

KEEN changed quickly, then drove off in his Dusenbergs for the City. He made good time, but even so, he saw that it was well after midnight before he reached 55th Street. And Lang was waiting for him when he got out of the elevator.

Without a word, Keen took out his key, opened the door, and allowed Lang to enter. The detective took a cigar from a box on Keen's desk, bit the end off and lit it. Still, neither one said a word.

Keen opened a newspaper he had brought along with him, and still Lang said nothing. He looked about the room carefully, then suddenly said: "It's certainly piling up on you, ain't it, Keen?"

"It sure is—er, what?" Keen answered quietly. "Have a drink?"

"You're sure going to be in one hell of a jam by tomorrow noontime—unless Grice turns up with that gun."

But Lang took the drink, nevertheless.

"And the ammunition," prompted Keen. "Don't forget the ammunition I was supposed to get."

"You needn't worry about that. We've got the ammunition," Lang said with an air.

"Oh?"

"Sure, we picked it up—six special cases of it aboard a boat out on the Sound near Montauk. At least the Coast Guard did less than two hours ago."

"Oh-h-h-h," gagged Keen. "That's interesting."

"And it was the Griffon again," continued Lang. "Left two men dead on board and a card stuck on one of the cases advising the Coast Guard to forward the ammunition to the U. S. Army testing ground at Ramshead Island by noon tomorrow."

"I get it. Then I'm coming back into the 'Griffon' character again, eh?" inquired Keen.

"If you are," snarled Lang, "you have two stiff on your hands. One of 'em was this bird, Renklund—the guy who rented the factory to Grice. It was his boat, as a matter of fact."

Whether Lang noticed it or not, Kerry Keen jerked.

"Renklund? Murdered? Why, that's the man who tipped you off about Grice being missing," he said to Lang.

"Yeh, but there he was with another guy named Angstrom, both chopped down sweet by a guy in a black plane—a least, the Coast Guard saw a black plane of some sort leaving there after they spotted some sort of distress signal being hoisted aboard the boat."

"And the cases of ammunition were aboard, too?" Keen asked casually. "Then the Grice gun should have been there, also."

"But it wasn't—and neither was Grice!"

"But you said Grice was killed in that flying-boat crash last night, didn't you? How many Grices are there?"

"Well, that was a phoney. We got him straightened out today. He was a Max Nordquist, a noted theatrical impersonator, who for some reason had gotten himself up to look like Grice," Lang explained.

"I wonder if he was the bird who impersonated *me* and got the ammunition," said Keen with an innocent countenance.

Drury Lang leaped fully a foot.

"By gorry, Keen. There's a tip. I never thought of that! Nordquist could have pulled that and got the ammunition. But what for?"

"To go with the gun, sap!" Keen spat. "That puts the stealing of the gun—and probably the kidnapping of Grice . . . er . . ."

"Go on, say it! You'll tip your mitt one of these days," Lang growled.

"No, I guess I'm wrong there, but there might be some connection between Renklund and this Nordquist chap. Still, if Renklund's dead, we'll never know."

"Renklund is dead and the Griffon guy killed him," stormed Lang.

"But then this Griffon fellow carefully puts a card on the ammunition cases and asks the Coast Guard to see that it is all sent to Ramshead Island. If you believe that, Lang, you ought to go and soak your head in brine and toughen it up a little more."

"Well, what do *you* think?" Lang almost screamed.

"I think this bird, Nordquist, got the ammunition for Renklund. There's a connection there somewhere, in spite of the fact that one died impersonating Grice and the other was murdered in a motor boat a day later. Renklund knew something of the gun. He might have planned to steal it, but would not take the chance without getting a sample of the special ammunition, too. The ammunition is important in automatic guns in order to get the correct recoil for the mechanism sequence."

Lang winced: "Take it easy. I can't get all that at once."

"You'll never get it. You're too busy

trying to ring me into something I know nothing about."

"No? Well, tell me why you ordered one thousand rounds of ammunition from the Packert plant—ammunition that fitted *only* the Grice gun!"

"If I told you, Lang," Keen taunted, "you'd know as much as I."

"Did you know John Grice?"

"Certainly I knew him—knew him well. I ordered the ammunition for him in my name because I had an account with the Packert firm. He was broke and couldn't buy the stuff."

"Say!" gasped Lang. "Then you couldn't—wouldn't have pinched his gun, or would you, if you knew what he had?"

"You're getting rather involved, Lang," Keen laughed. "What are you trying to say?"

"If you knew Grice well enough to take on that amount of money for him, you wouldn't pinch his gun, because you couldn't do anything with it unless you took it out of the country, could you?"

"Go on," smiled Keen.

"And you wouldn't kidnap John Grice just before he was going to show his gun to the Army, who will buy it allowing him to pay you back. Would you?"

"No," leered Keen, "which leaves me only one hole left."

"What's that?"

"I must be the Griffon, Lang. I must have killed Renklund and his pal to-night, even though I have never seen him and wouldn't know him if he walked into this room."

"Listen. Let's forget that 'Griffon' business, I'm ready to call this quits," Lang muttered.

"Only I am supposed to produce John Grice and his gun by noon tomorrow—at Ramshead Island."

"Yeh."

"And not a chance in a thousand, is there?"

Lang wagged his head, then stopped and smiled. "A chance in a thousand, Keen? I think there is—in those thousand rounds you ordered for John Grice. Unless he turns up with his gun, you don't get your dough back. And those thousand rounds of ammunition, I understand, were *very* costly ammunition, too, Keen."

"It was," agreed Keen. "Very costly."

"So what?"

"So Mr. Grice and his pop-gun will *have* to be at Ramshead Island by noon tomorrow, eh?"

"Or you're out the price of one thousand rounds of very costly ammunition," Lang said getting up and going to the door. "Very costly ammunition, Mr. Keen. Good night!"

And Drury Lang went out.

"I was thinking of that, Mr. Lang," muttered Keen, "when I snatched Mr. Grice, last night."

THE recollection of Grice brought up the matter of the Dornier that had tried to attack Graylands only a few hours before.

Keen shuffled the events through his mind and came to the conclusion that the pilot of the Dornier torpedo-bomber

was a member of the Renklund gang, but that there had been some sort of a slip in their plans.

"He finished off Renklund and his cabin-cruiser pal," Keen mused, mulling it all over. "He is still in circulation, somewhere, and will probably try to get Grice yet."

The realization of that fact brought him to his senses. He called Barney out on Long Island, made plans for quick action. Barney agreed to get the Black Bullet ready.

Keen darted out of his study, took the elevator down. In five minutes more he was backing his Dusenbergs out of the garage and heading out for Long Island.

"Renklund was evidently trying to make his get-away with the gun and ammunition while his Dornier pal was taking care of Grice at Graylands. That means one thing, at least. They know I have him there, or they think I am the Griffon. No matter what, Grice has to be moved out of there quickly."

He stepped on the gas, raced across the Queensboro bridge, and thundered along to his Long Island estate. Barney had everything ready when he arrived; and as soon as the car was put away, they both climbed into their black coveralls and adjusted their masks. Then they went into the portion of the house where John Grice was kept a prisoner. He was in bed and had to be aroused. He was in no pleasant mood, either.

Keen spoke through the mouthpiece of his headset and the metallic tone completely disguised his voice.

"I'm sorry, but things are getting a little too hot for you here, Mr. Grice. We'll have to move you to a more secure base."

"This is the most damnable treatment a man has ever been forced to put up with," old man Grice growled.

"We are sorry, but it can't be helped. You do not seem to realize what danger you have been in during the last twenty-four hours."

"Danger? I'll take care of myself if you'll let me out of this accursed hole! I tell you I have an appointment with the United States Army at noon tomorrow. Tomorrow is Wednesday, isn't it?" Grice growled climbing into his clothing.

"You do not seem to realize that two attempts have already been made on your life." Keen tried to explain. "You need not worry about meeting those Army officials. You'll be there, all right!"

"I object to being cooped up like this. You have no right to hold me a prisoner. I could be looking for my gun—or at least having someone look for it. All this is wasted time. They may be getting it out of the country."

"Don't worry," Keen said in a cheery voice. "They won't get your gun out of the country. You can leave that to me."

"Leave it to you, bah! Eighteen years of effort. Eighteen years of hard work—all for nothing. I'll never be able to pay my bills, and you coop me up in a rambling old building somewhere on Block Island, isn't it?"

"Near Provincetown, would be nearer the mark," Keen fabricated tonelessly.

"But never mind. We'll see that you get to Ramshead Island in time for the official showing."

John Grice swore under his breath, but completed his dressing. Then they wrapped him up in a warm overcoat and again bandaged his eyes. They guided him carefully down the stairs and into the underground hangar. Keen helped him into the cockpit while Barney opened the hidden doors and waited until the Black Bullet was eased out onto the turf. Then Barney pressed the button that closed the doors, swung the wings out, and fastened the king-pins.

Quietly Keen ran the amphibian into the water and finally took off. Barney huddled down under the rear gun mounting and watched John Grice.

KEEN headed almost due east when he had cleared the swinging glare of Montauk Light. He climbed to about 4,000 feet before he cut out the mufflers. Then they settled back for a flight of about eighty miles—eighty miles of amazing speed across the open Atlantic toward Muskeget Channel which runs between Martha's Vineyard and Nantucket Island.

Ramshead Island lay in Muskeget Channel facing Nantucket Sound on one side and the ocean on the other. For years it had been used by the Ordnance Department as a testing base for certain types of aircraft rifles. It was secluded, suitable for the work involved.

There was a small collection of comfortable brick hutments for the handful of Ordnance workers who stayed there the year round. In addition there was a long shop containing suitable machinery for making repairs or changes on pieces of ordnance. There was a special storeroom for various types of weapons and a magazine, set well away from the rest, where ammunition was held ready for the scheduled gun tests.

The magazine was a low brick affair set deep in the ground. A metal door led to the steps which ran down to the waterproof cellar. In racks and bins of various sizes were stacked various shells from three-pounders down to the ordinary small arms calibre ammunition.

Fortunately, Kerry Keen knew the layout well, as he had been to Ramshead Island on several occasions to consult with Ordnance officers on important points in which ballistics were involved. He knew where every particular hut lay.

They arrived over the southern shore of Martha's Vineyard in about twenty minutes, then Keen settled back and eased in the Skodas. He let the Black Bullet skim along at about 150 until they saw the shapeless outline of Ramshead Island. Then he slowed down, swept into a glide, and curled back and forth, watching carefully for any movement of surface craft below. With a glance around at Barney, he then nosed down, slowed the Avia to a mere idling speed, and planted the pontoons on the swells that rolled toward the sandy beach in front of the testing station.

The Skoda mufflers soothed out the purr and Keen was able to run the black amphibian up on the hard-packed sands with little trouble. Then, before making

another move, they turned her around and set her nose toward the sea. Quietly, they got John Grice out, ordered him to march.

"Where are we?" demanded the annoyed inventor.

"You'll find out in the morning," Keen said quietly. "Now move on and not a word out of you, or we'll be forced to take harsh measures."

Barney followed carrying a bundle carefully stitched up in heavy burlap, also two Army blankets and a pillow. He was puffing like a grampus as they scurried up a sand-dune, but Keen kept them moving fast.

Once he halted, listened carefully.

"Down!" he husked. "Lay low, Grice, and not a word!"

A sentry came into view at the edge of the post, halted a minute, then turned on his heel and slowly trudged back down the path toward the group of brick huts.

"All right!" whispered Keen. "Not a word, Grice, or we chuck you completely."

"I'll drop this on his nut, if he even wheezes," growled Barney. "Gorry, this is heavy!"

Keen led the way across the dune to a low brick building half buried in the sand. He fumbled for a minute with the padlock that held the hasp of the steel door. He worked skillfully with a short steel hook and managed to pick the lock. He drew the door up carefully, started down.

"Where are we?" demanded old Grice.

"Take his bandage off, Pulski," Keen said.

"You take it off, Ginsberg," replied Barney. "I got me hands full now."

"Pulski . . . Ginsberg!" derisively snorted John Grice.

Keen flipped the bandage off, drew out a small pocket torch. "Keep your trap shut, Grice," he muttered into his mouthpiece, "or I'll gag you!"

The light showed a narrow passage between two rows of steel bins. Old Grice stared at the racks of ammunition, and wondered.

"Come on," Keen snapped. "Take those blankets there from Pulski and make yourself comfortable on this bench. They'll come and get you in the morning. Put that bundle of grub and stuff under the bench Pulski. He can get his own breakfast in the morning."

"Well, I've slept on workbenches before," Grice muttered. "I guess I can do it again, but this is a hell of a place to imprison a man. It's a magazine, isn't it?"

"It is, and you'd better not smoke in here, or they'll be scraping you off a cloud, somewhere."

The interior was warm and dry, but none too airy. Still, it was better than nothing and a lot safer than many places where John Grice could have been.

Barney shoved the heavy bundle under the bench, helped Grice roll up in the blankets.

"There'll be an inspection in here tomorrow morning. They'll find you then,

and you can tell them how you came here."

"With Pulski and Ginsberg, eh?" snarled Grice. "I don't know what this is all about, but none of it makes any sense."

"Never mind that part of it. Snuggle down and when you get up in the morning you'll find all you want in the bundle under the bench. Good night!"

"Good riddance," stormed old Grice as he rolled over.

"Same to you, you ungrateful old devil," Barney replied. "You don't know when you are well off."

"Come on," snapped Keen. "We're wasting time!"

"Listen!" snapped Barney. "Listen."

"Come on! I get it! That Hispano-Suiza engine again—the Dornier!"

QUICKLY, Keen ran along the corridor of the magazine and darted up the steps. Barney followed and together they carefully closed the door and snapped the lock.

A moon had broken through and they saw the sentry striding toward them. Without a word, the two men in black turned, darted across the dune, and began running toward the black amphibian.

"Halt!" the sentry cried. A shot rang out, but Keen and his mate were scrambling down the other side toward the shore. Together they leaped into the Black Bullet as the sentry topped the crest of the dune. He fired once more, but by that time the black plane was rolling down the hard-packed sands toward the water.

He fired again and a bullet cracked the splinter-proof glass above Keen's head.

"Nice shooting, son. But we're sorry," he cried.

The black amphibian caught the rollers. Keen took out the mufflers and she leaped at the surge of power that thundered from her metal lungs. Then they hit the top of a roller and leaped into the air.

"Here he comes!" screamed Barney. "Same guy!"

"Same egg under his belly, too."

"What's the game?"

"Same game. He followed us, figuring what we were up to. He know that Grice, or the gun and perhaps the ammunition, is here. He's after the magazine. Look!"

Keen yelled, ripped the black amphibian over hard, and rushed at the diving Dornier. Barney opened up his rear guns, poured a torrent of lead into her, and made her turn slightly. Keen ripped his nose over again as they cleared and pushed the wing guns at the Dornier. They chattered hard, belched fire. The Dornier staggered once, recovered, and then her gunner opened fire and rapped hard on the Black Bullet's wings.

"There he goes again! He's after the magazine. He probably thinks the gun is hidden there now."

"It is, but so is old Grice," yelled Keen.

"Let's go!"

The Dornier was fighting to get back into position. Keen battered away at her

Advertiser's CONTACT

A LITTLE NEWSPAPER DEVOTED TO A BIG CAUSE ★ OF, BY AND FOR FLYING ACES CLUB!

VOLUME 24

JULY, 1936

WHOLE NUMBER 35

"More and More F.A.C. Squadrons Take to the Air But Still No Light Plane Advertisements!"

Los Angeles Leader Feels that Manufacturers Have "Hibernated"

CAPTAIN Frank Turri, of our Angeles F.A.C. Squadron—the Legion Aeronautica Mexicana—wrote us recently in connection with the article appearing in these columns in the May issue, dealing with the manufacturers of "Upstairs Equipment." Frank's letter, in part, follows:

"Capt. Stanley Dowgiala, of N. J. Squadron No. 3, has asked why advertisements of flying gear, such as goggles, helmets, coveralls, instruments, etc., are 'dead stick' on the advertising columns of FLYING ACES. We out here in L. A. have not only been wondering about that but we'd like to find out why the manufacturers of light planes have likewise 'hibernated.' More and more F.A.C. Squadrons continue to take to the air—but still no light plane advertisements! We're in the air, as you know, flying out of Culver City Airport; and I for one feel that these manufacturers are certainly not paving the way to future business by passing up FLYING ACES."

Our Californian friend has hit the nail on the head, F.A.C.'s—these manufacturers are overlooking the fact that our host of FLYING ACES readers, numerous aero friends, and honorary members, many of them famous flyers, offer a logical market for airplanes—especially for the light planes that can be purchased so easily for training purposes, as demonstrated by various F.A.C. units.

We know from the interest that you Buzzards have shown in our Light Plane Tarmac that you readers are interested in seeing airplane advertisements in your magazine. From the many letters we've received in connection with the ships depicted in this new department, we're mindful that you want to learn all you can about these fine

American sport ships so that when you're ready to purchase you'll know what to buy. Also, with many of you in the market right now, it's too bad that you can't turn to the advertising pages of this very issue and look 'em over.



Captain Frank "Stormy" Ylizalturri, Legion Aeronautica Mexicana, Los Angeles. The members of his fine F.A.C. outfit spend more time in the air than they do building models!

But what are we going to do about it? Are we of the F.A.C. going to sit back and let the light plane manufacturers think we're a bunch of kiwis—that we don't know a prop from a tailskid? Bear in mind—one of these days the manufacturers of light planes and flying gear are going to "wake up," and when they do they're going to pick out the magazine that boasts a following of the most promising bunch of future flyers. We all know that magazine is FLYING ACES—but the only way the

light plane manufacturers will know of it is through you and you and YOU! Come on F.A.C.'s—let's get busy and write these manufacturers. Let 'em know that you build models mainly so that you'll learn to comprehend the actual construction of aircraft against the day in the near future when you'll be in the market for a plane. Point out that FLYING ACES is the air publication in which to advertise. . . . Call their attention to the Club News columns, conveying monthly information of additional F. A. C. Flights and Squadrons taking to the air. . . . And mention that almost every famous flyer in the country, as well as many foreign flyers of note, are honorary members of the F.A.C.! Let's not just a few of us write, for a few will not count—let's ALL respond to this call.

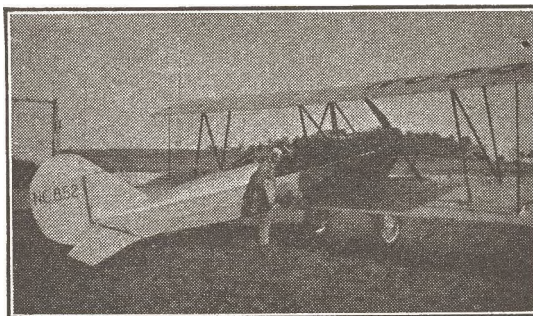

Introducing one of our "Independent members"—John Gall, Piney Fork, Ohio. While many of our members are banded together into Flights and Squadrons, we number in our membership hundreds of Lone Eagles, like John. We don't know where he bought the ship or the outfit—but we do know he bought FLYING ACES before he bought either. Instances such as these definitely prove that airplane and accessory manufacturers are losing money by not using the advertising columns of FLYING ACES.

with his front guns and tried to drive her off. But the pilot was adamant and hung there, heading straight for the sunken magazine. Keen knew that if he yanked the toggle that released that 1,000-pound torpedo, it would crash deep into the magazine and blow it to smithereens. That meant Grice, his Flexthud gun, and everything else!

She simply had to be stopped!

He raced at her again and faced a bitter fire from the back seat. Barney was screaming at the top of his voice, and firing like mad.

The silver Dornier was a beautiful thing poised there, but she had no beauty for Kerry Keen. He raced in, blasted everything he had at her and watched her stagger, zoom up crazily, then plunge downward.

"Got him!" bellowed Barney.

"Poor devil!" snapped Keen. "Dead man on the stick. Watch him!"

They could see the man's head back on the crash pad for a second or two, then the Dornier came up madly and began to tail-slide. The pilot's head now slapped forward and the Dornier rolled over on one wing and nosed down into a spin. The hand that had been on the torpedo-toggle, jerked convulsively and the long projectile plummeted from its carriage. They watched it plunge down and hit the sea with a low plop. The Dornier followed and hit into the spume of spray the torpedo had sent up. Then there came a terrible explosion and the sea was flecked with scarlet and yellow flame. The Dornier broke into pieces, threw its wings and tail members in all directions.

"Ugh!" gulped Barney. "That's the way to get it. Get it right!"

"They'll never chase old Grice again. Let's beat it. I have an idea Lang will be calling early in the morning to ask me a few pertinent questions. I like to accommodate him when I can."

And the Black Bullet raced back to Graylands eighty miles away.

N NEITHER Barney nor Kerry Keen awoke by noon the next day. As a matter of fact, neither arose until near-

ly 4 o'clock in the afternoon, at which time the telephone bell aroused them.

Warily, Keen answered it, while Barney poked his frizzy red head in at the door expectantly.

"Hello?" Keen answered. "That you, Lang?"

"Sure! Don't tell me you're in bed! You should have been out at that gun test today!" the exuberant Drury boomed into the receiver.

"Gun-test? Oh yes! That was today, eh?" Keen replied slowly putting on his act and winking at Barney. "How did they make out?"

"You'll get your dough from old Grice, all right. It went over with a bang."

"But wait a minute," gulped Keen. "The gun — and Grice. Were they there?"

"Sure! Darndest thing you ever heard. They found Grice and his gun in the magazine early this morning when they were putting that . . . those cases of ammunition you had bought for him into the shell vaults. There he was—gun and everything—waiting for them!"

"I can't believe it," answered Keen. "How did he get there?"

"Well, I'll tell you, Keen," Lang explained in a confiding tone. "I think the guy's nuts. You know these inventors."

"All nuts," agreed Keen.

"He tried to tell us that he was kidnapped the night before by two guys in black named Pulski and Ginsberg—you know that old 'Griffon' gag—and taken somewhere on Block Island. Then they brought him and the gun to this magazine and hid 'em there last night."

"Someone is crazy," agreed Keen.

"Yeh—and yet the sentry claims something queer happened. There was a hell of an explosion, too. Everyone heard it, and he also tells a yarn about a black seaplane, or something, that took off and shot down a silver ship that seemed to be trying to land on the island. Anyway, they found the wreckage off

shore. But there was not much to work on."

"Sounds silly to me."

"Well, anyway, old Grice put on a show with that damn pop-gun of his that had those Army guys standing with their eyes sticking out."

"They going to buy it?"

"Sure. Old Grice stands to make half a million. You'll get your dough, all right. Don't worry."

"I wasn't," said Keen.

"No? Well you looked pretty glum when we had you on the coals down in the city yesterday. What was you so worried about, anyway?"

"Well, when a fellow is kidnapped and is gun is missing and there's Griffon cards all over the show, what was I to think? You always try to make me the goat, you know. Besides, when you told me that old Grice was found dead in that seaplane . . . er . . . flying boat out there in the Sound . . . things didn't sound so good for my dough."

"Say! That's right! I wonder what that bird was up to, impersonating old Grice. He was out on Block Island at that time. I wonder what their game was!"

"I think he was looking for the Griffon—to get those blueprints," said Keen winking at Barney again.

"The Griffon? Why what had he to do with it?"

"The blue-prints were with the gun, weren't they?"

"Sure—wrapped up in the burlap wrapping. At least that's what old Grice said."

"All right. Then the Griffon had them all the time and that guy Nordquist was going to try to get them back from the Griffon. He must have known where he could be found, eh?"

"Yeh," agreed Lang painfully. "And Nordquist and the rest of them are dead. Just my luck!"

"Yeh," laughed Keen. "Just your luck, Lang. Hang up, will you, I'm very hungry."

Scratch-As-Scratch-Can

(Continued from page 16)

"Oh, awright, come on," the master of this canine of 57 varieties weakened. So Rollo trailed him up the steps of Mam'selle's. Babette greeted her swain with French enthusiasm and opened a bottle of *vin rouge*.

While Phineas sipped at the Frog liquid nitro, she began a campaign. "Vous take Babette *ce soir* to ze circus, non?"

"Circus?" Phineas gulped. "There wasn't no sign of a circus any place when I come in. Ha! ha! Thees ees ze joke, nest paw?"

"*Mais non*," Babette replied, shaking her head vigorously. "She ees ze fleas circus, *oui*. Mabe ze bes' fleas circus from all ze worl' *vraiment!* Professair Rene de la Bouillaise, he ees ze bes'

trainair of ze fleas in ze worl'. He has ze nam' for ever'wan of ze flea. Napoleon, Josephine, Madame Dubarry, *et Le Pompadour. Aussi Danton et Lafayette. Ah, voila!* Zey pull heem ze chariot *et zey do le dansant. Oo la la*, she ees *tres magnifique!*"

"Boys, *nous* are already in ze joint," grinned Phineas. "I have always wanted to see a flea do a fox trot. Let's *allez, ma femme*—veet—trays veet. Where ees eet ze circus?"

"I show you," Babette said and reached for her hat.

Rollo dogged the footsteps of the pair until they turned into a small theatre a block from the Cafe de la Vache Rouge. The representatives of many armies and a motley array of townfolk had already clogged the place. Standing room was at

a premium and Phineas and Babette were forced to be content with a view from the doorway. Rollo, however, made his way through a maze of undercarriages and selected a spot close to the wall not ten feet away from the manipulator of the tiny winged actors the audience had come to see.

Professor Bouillaise soon got down to business. "Mesdames et Messieurs. I have *ici* ze greates' fleas in ze universe. I start off *avec* Napoleon. He weel stan' like ze great Bonaparte when he have look away from ze shore of Elba. Step up an'—*sacre! Mon Dieu!*" The professor dug his fingers into his scalplock and rummaged fiercely. "Zey have go! Ze case she ees come open—I forget! *Ah, sacre bleu!*" He got down on his hands and knees and began to emulate Rollo

when that pooch was in his most eager hunting state. "Ever'body, hunt for ze fleas!"

Feminine shrieks began to pierce the air of the theatre. A hurried exodus began and the place was emptied with incredible speed. Phineas lagged behind, eyeing Rollo closely. The pooch was making a pass at a certain spot on his anatomy with a hind foot. Giving that up, Rollo made a lunge at one shoulder blade with what remained of a mouthful of decrepit bicuspidis.

"Yipe, yipe! Ki—yi-i-i!" he sang out in protest.

Professor Bouillaise, still on all fours, took a gander at Rollo. His eyebrows slipped up and became lost in a disheveled thatch of hair. "*Mon Dieu—ze chien! Ze fleas—sacre!*" He made a hasty dive for Rollo. Rollo pulled himself together and galloped out into the night, his yipping growing fainter and fainter as he sped on.

"Catch heem, ze *chien!*" screamed the Frog fleamaster. "*Ze chien!*" he howled at Phineas. "Y-You have steal ze fleas. Zo! Thees ees why you have come. Ah, you are jealoos—ever'bodee he ees jealoos for ze fleas. Ah, I get ze *gendarmes!*" The professor was as good as his word. In two minutes a dozen French cops were milling around in front of the theatre, but Phineas Pinkham was already slamming the door of Babette's domicile behind him.

"Whew-w-w!" he gasped. "Haw-w-w! I bet Rollo is huntin' for somethin' for scratch with. Well—"

"*Allez vite!*" shrilled Babette. "Always you mak' ze *tres beaucoup* trouble. *Non mattair* where I go *avec* Phinyas, ze *gendarmes* chase me back *chez moi*. *Vous allez*, Pheenyas, *veet! Mon Dieu!* Bettair I be ze femme of ze peekpockets. Lak' *vous* say a *moi*—nuts to *vous!* Pheenyas!"

"Awright," the trickster clipped, "I can get lots of *femmes*. *Vous* are gettin' ze air—comprency?"

"*Et vous* are gettin' ze fry' pan," Babette threatened, leaping toward the stove.

Phineas got out fast. As he stood in the darkened doorway he could see M. P.'s and *gendarmes* running around as thick as Scotchmen at a free clam-bake.

"I—I could alibi about the pooch," Phineas gulped. "They couldn't prove I stole them fleas knowingly. But I am A.W.O.L. an'—well it looks like it's the bastille for me. A midget meadowmouse couldn't git through them—ah—er—ugh!"

JUST then the sky pulsed with the churning of *flugmotors*. Dark shapes appeared in the skies over Bar-Le-Duc. M. P.'s started running for cover. *Gendarmes* were already diving into cellars. A siren ripped out and the streets became as empty as a butcher shop in Cork, Ireland, on Good Friday. The Boche Gothas were on the prowl.

Phineas Pinkham seemed to be enjoying it, however. He walked out into the street with the sang froid of Whittier's barefoot boy and headed for the nearest egress from the village. Rollo was no-

Take Advantage of
LINCOLN'S
 Complete Training...
 ...for a GOOD PAY JOB
 in AVIATION



LINCOLN GRADUATES WIN THE GOOD PAY JOBS

Many *Lincoln* graduates are employed by leading airlines, factories, airports and service stations. Through our acquaintance and contact with the industry, we recommend our graduates for positions as pilots and mechanics.

Remember, *Lincoln* has for a quarter of a century been sending excellently trained men out into the world to win success and rich rewards. Now in 16th year teaching aviation. Our graduates have set such a splendid record with leading aviation concerns with whom they have been employed that other graduates are in demand.

Part Time Employment

Now, we can offer a limited number of ambitious men part-time employment to cover cost of board and room while training. Now is the time to start at *Lincoln*.

LINCOLN AIRPLANE & FLYING SCHOOL

Now in the 26th Year . . . 16 Years Teaching Aviation
 284 Aircraft Building Lincoln, Nebraska



Young Man! Aviation now offers you a most attractive opportunity for a brilliant and successful career. The aviation industry is experiencing the greatest increase of business in its history. Aircraft factories throughout the country are working over time to fill huge orders for new airplanes. Government orders alone amount to many millions of dollars. THIS MEANS THOUSANDS OF GOOD PAY JOBS for service men, mechanics and pilots with proper training such as we give you at this *Lincoln* School.

Get Your GOVERNMENT PILOT'S LICENSE

—There is an advantage in training at this "World's Best Known Aviation School" for your Government Pilot's License. *Lincoln* Approved Flying School training includes everything to make you a first class Pilot. Here you train for Government License as Transport, Limited Commercial, Private or Amateur Pilot. You learn straight flying, night-flying, blind flying by instrument, radio beam flying, cross country flying, acrobatics, spot landing, aerial navigation—everything to meet government requirements, and more.

Get Your GOVERNMENT MECHANIC'S LICENSE

—*Lincoln* Approved Mechanics School training is all-complete, giving you every requirement for Government License as Airplane and Engine Mechanic. You rebuild modern aircraft engines such as Whirlwinds, Wasps, Cyclones, Aircraft Diesel and many others. You rebuild modern airplanes under factory standards. Training also includes aerial radio, welding, instrument repair, machine shop practice, etc. **SHEET METAL TRAINING**—We train you here in our modernly equipped sheet metal department for the high class workmanship required in building and repairing of latest type all metal planes. Big demand now for sheet metal workers and welders.

GOVERNMENT APPROVED SCHOOL

Both the *Lincoln* Flight and Mechanics Schools are under Government Supervision. Our fleet of training planes includes high and low wing monoplanes, open cockpit biplanes, small and large type cabin planes, all inspected and approved by the U. S. Dept. of Commerce. Government licensed flight instructors give you every phase of flight training to make you a dependable, high class pilot. Mechanics training taught under factory standards with ample shop and laboratory practice to make you a capable mechanic. *Lincoln* stands on its merits as a school—not a side line of any other industry.

MAIL THE COUPON NOW

Now is the time to start training at *Lincoln*—for the thousands of big pay opportunities which are being created by the tremendous aviation development programs under way in practically every country. Get the facts. Mail this coupon at once.



LINCOLN AIRPLANE & FLYING SCHOOL
 284 Aircraft Bldg., Lincoln, Nebraska

YES! I want further facts about LINCOLN'S complete training and the big-pay opportunities ahead in Aviation.

NAME AGE.....

ADDRESS

CITY STATE.....

where in sight. He whistled once but the pooch did not appear. Then he turned his footsteps toward the Ninth Pursuit, his thoughts on how Monk Flanagan had liked the cognac he took from Bump. Quite a coup that he had remembered Monk's yen for strong brew.

"I bet Rollo will be home when I git there," mused the prodigal pilot as he headed for the drome. "I must get me some borax and water to drive out the fleas. I—"

BO-O-O-OOO-OOM! The houses on either side of the street shook as if two fighting bull elephants had collided with one another. Another explosion followed seconds after the first. A chimney toppled and Phineas had to be spry in order to escape the flying Irish confetti.

"Huh," sniffed Phineas, "it's the Vons blowin' up Allied grub an' ammo again. If they wait for Monk Flanagan to find the dirty Kraut bums on this side, well—there won't be a cracker even for the doughs to eat or—huh, a Major! I should be higher than Pershin' at that rate. It's a fine *guerre* when a bum like that—"

BO-OO-OOOM! Phineas slapped his hands to his ringing ears and groped toward the outskirts of town. Suddenly two grim-visaged figures loomed up in front of him. One yelled at him and pointed to a wide open space.

"So you're an aviator, are ya? Ha, where were you when the Gothas come over? Is that your Spad out there? Well, hop into it, you—you winesop. Been drinkin' grog while the Gothas blow hell out of—what's your name, you—?"

"Smith!" Phineas yelled as his eyes lined up the Spad that squatted on the real estate not a hundred yards away. "Uh—that's not my—er—oh yeah, I forget things easy. Ha, can you imagine that? I would misplace an elephant if I—right away, sir. I'll get the Spad an' knock the h--- beat them Krauts. Thank you, sir."

"Sounds nutty to me," the infantry officer opined.

"Drunk, that's what," his companion ripped out just as another Gotha egg shook the ground under their feet. "All flyers are drunk or nuts. That egg hit closer. The Gothas are on the way back and if any crates are chasin' 'em, they'll unload the rest of the pills. Let's duck, Nick."

Phineas was climbing into the strange Spad when the Gothas skimmed by overhead. It was too late to chase the Heinies now. Another egg almost struck oil outside of Bar-Le-Duc when the lone Yank finally got the Hisso of the Spad turned over. The power plant was as cold as a stepmother's blessing and it was fully fifteen minutes before the joke professor was in the air.

"It's nowhere near Christmas," he yipped as he climbed toward the milky way, "but Santy Claus came around just the same. Well, they ordered me up. I did not want to take this crate. It was forced on me against my will. Haw-w-w-w-w! Did it make me sore?" He headed eastward in the direction of Vold and a place to set the Spad down for the night. The gas gauge indicated that he had enough pep juice

left for practically three hours of flying.

Fifteen minutes after leaving the environs of Bar-Le-Duc Phineas dropped sky space and hedge-hopped over a sleepy Frog hamlet. Outside the town he picked himself out a passable landing field and set the Spad down. That night he slept in the ruins of a brick kiln dreaming of the things that were going to happen to one Monk Flanagan. He woke up out of a dream in which he imagined Rollo was licking his chin with a file-like tongue. The sun was shining into his eyes when he sat up and looked around him.

"Well it's some flyin' day," the absentee from the Ninth commented sleepily. "I wonder where Rollo is? I've got a good idea where Flanagan is at, though. And then there's von Bull. It ain't right for one guy to have so much on his mind." He dug absently into his pocket and pulled out a little diary. Inside the cover was a calendar. "I got to start gettin' some of it off my mind," he said to himself. Then he let out an ear-splitting howl. It was Friday!

"This is the day the Kraut said he would knock my ears off!" he wailed. "An' me without my own Spad and nothin' prepared. But a Pinkham never backs down—he fights for his honor!" Suddenly he remembered something. He fished into the pocket of his trench coat and yanked out a gun. A cryptic smile spread on the Pinkham pan. "It's somethin'. It gives me an idea and that is all a Pinkham asks." He tested the gun that had intrigued Bump Gillis then put it back into his pocket.

"Von Bull," Phineas said solemnly, "the treader will meet you anon. Sharpen up your horns, you Prussian bum!"

THERE was consternation in Chaumont that day. It spread to air-dromes, to every divisional headquarters along the pulsating front and back again. The hidden Allied supply dump near Boucq had been washed out by Gotha eggs—a dump that was camouflaged better than a crow sitting under a black derby hat. Insulation was burned off wires leading to Intelligence officers as the Allied moguls sizzled. Could the Intelligence find a beard in Russia? Could they find a smell in Limburger? Would they like to go around saluting mule drivers for the duration of the war? These and like insults flowed in abundance.

And in the Operations office of the Ninth Pursuit Squadron Major Rufus Garrity paced up and down and thought up a fit punishment for Lieutenant Phineas Pinkham. In a corner of the big room outside sat a determined Frog who, by profession, was a trainer of fleas. Moreover, the said Frog had announced his intention of sitting there until Rollo appeared. He had informed the Old Man that he had found out who owned the pooch through a C.O. of a neighboring squadron. It seemed that one of that C.O.'s Spads had been stolen the night before from where the pilot had left it outside Bar-Le-Duc. Of course, it was very convenient for him to have been seized with cramps in the

vicinity of the town thereby being forced to land and seek liquid relief, but was it too much to expect to find his Spad where he had left it? Said the Frog in hysterical French-American jargon "Put heem ze wan-two side by each!" The Spad was missing and so was a certain Lieutenant Pinkham.

"He'll get shot this time!" the Old Man ripped out to the audience watching him do the fortieth lap around the big room. "I want to see it. I'll sit there readin' a book when they stand him up against a wall. A deserter—larceny of government property. A fifteen thousand dollar Spad! Maybe he even blew up the groundmen's kitchen. He's in a sling this time for sure."

"I wonder where them spies are at?" speculated Bump Gillis, completely disregarding the fact of Phineas Pinkham's latest exploit. "They sure had that dump tagged. I got a look at it when I flew over this a.m. They must've laid a baker's dozen of eggs on it. What an omelet!"

"Shut up!" Garrity bayed. "Who asked you?"

"Poor Pinkham," sighed Captain Howell, "he better get himself killed to cheat the U. S. courts."

"This is one time he don't crawl out," erupted the C.O. "Stealing a Spad! Deserting! Insulting a Major! Stealing fleas!"

"It was the pooch," Bump protested, belatedly defending his hutmate. "Maybe you think Carbuncle carried each flea over to Rollo and hid it in the pooch's fur coat."

"All of you—get to h--- out of here!" erupted the Major.

THE Rittmeister Gottfried von Bull climbed into his Pfalz bus at four-forty-five and began to goose the Mercedes power plant. Just before he took off, the Heinie officer instructed his *Staffel* cronies to get either a strong cell or bouquet of posies ready as he was going to get the upstart, *Leutnant* Pingham one way or the other.

A tall, monocled Kraut, who had flown once with a Teuton named Mannheim, clipped sardonically, "*Der* duck-links don't count idt already yedt before *der* Mudder duck hatched *ist* vunce, ja!"

"Zoak *der* headt, Heinrich," shot back von Bull. "*Auf Wiedersehn!*"

Phineas Pinkham took off from his private tarmac at about the same time as the Heinie acc. Both crates drilled over to the sky ring at about the same speed. So they must have reached the same spot above the fighting ditches at the same time. Such was the case. Von Bull bellowed like the bovine for whom he was named and he immediately began to heat up his Spandaus. Phineas said a prayer, hoped for the best. The red bandanna that flew from his tail irked the *Rittmeister* as much as a red flag riles a horned ruminant in a Spick bull arena.

But the battle was of short duration. The Spad took two bursts to the midriff and Phineas began to reel around the sky ropes.

"Ach, sooch *ein* flyer *Ich* ben!" von

Here's a Buy!

You Won't Forget it for a Year!

- - - an offer you can't afford to miss!

In fact, the headline to this announcement should read, "\$1.40 in Cash Free to every person answering this advertisement." Sounds like a strong statement but it's true. And it means exactly that when you send in your

YEAR'S SUBSCRIPTION to MODEL AIRPLANE NEWS



during this sensational offer

Here's why:—at 20c per copy on news stands it costs you \$2.40 per year. But price should not be the only deciding factor in making up your mind to subscribe to MODEL AIRPLANE NEWS—the one magazine that puts model builder and flyer on the same plane. MODEL AIRPLANE NEWS is written for boys and their fathers, with a common interest for both. No fantastic fiction, no imaginary tales of the air, no blood-curdling aerial combat stories—but instead, 48 pages of clean, authentic, timely, crisp information prepared and written in a manner that is appealing to every reader—true-to-life data about model planes and the real ships from which they are designed.



Here's what you get **FREE** With each subscription during this special offer:— **COMPLETE KIT TO BUILD A FLYING MONOCOUE**



And what a sensational flyer this model is when she takes the air. It is a product of a well-known model airplane manufacturer who has built up a reputation for guaranteed flyers. The Monocoupe has always been a popular model and here is your chance to get one without any cost whatever, while you are saving \$1.40 on your subscription. Don't delay! Send your dollar now. There are plenty of thrills in store for you.

This offer expires August 6th, 1936

Think about this offer just a moment and you'll thank us for an entire year.

For 12 MONTHS

Here is the coupon that brings you Model Airplane News for one whole year at less than 8½ cents per copy. Fill in and send coupon now!

Jay Publishing Corp. FA7
551 Fifth Avenue, New York, N. Y.

Enclosed find \$1.00 for which you are to send me MODEL AIRPLANE NEWS for One Whole Year beginning with the current issue, as stated in your Special Offer.

I am also to receive at once, FREE of Cost, a complete kit to build a Flying Model of the Monocoupe 110.

NAME
ADDRESS
CITY STATE

---THEY ADVERTISE---LET'S PATRONIZE---

FLYING ACES Says:

"We wish that every reader of FLYING ACES could buy, or at least borrow, a copy."

THIS FLYING GAME

By BRIGADIER GENERAL H. H. ARNOLD,
Assistant Chief of the Air Corps
and MAJOR IRA C. EAKER, Air Corps

Here, in a lavishly illustrated volume, are the answers to the questions—How can I get into aviation?—What training do I need?—How do I acquire it?—What sort of examinations, physical and mental, need I pass?—What is the life of a flyer like?—What prospects of a job are there for the flyer who has acquired his training, and what kind of job is it anyway, this flying game? These and many other questions are competently handled by one of the foremost flyers of his day.

\$3.00; post-paid, \$3.18

FUNK & WAGNALLS COMPANY, Dept. 1595,
354 Fourth Ave., New York.

Enclosed is \$3.18. Please send me, post-paid, a copy of "This Flying Game."

Name

Address

City State

Superior Detailed 20" FLYING SCALE 25c MODELS

Notice: 2 months ago these kits sold for \$1 each. But due to stiff competition we have dropped them to 25 cents each.

FIVE MODELS TO CHOOSE FROM:

- (1) Macchi Castoldi Scaplane
(2) Boeing P26 Low Wing. (3) Fokker DVIII.
(4) Vought Corsair. (5) Boeing F4B4.

EACH KIT CONTAINS

Superior detailed plans, finished 7" prop, all formers, ribs, etc., clearly printed on balsa sheet, wire parts, cow! block, wheels, nose plug, bearing block, colored Jan tissue, rubber, dope, cement, balsa strip cut to size. Add 10c for packing & postage. West of the Mississippi and Canada 15c.

RIDDETT MODEL CO.,

109A MORNINGSID AVE., YONKERS, N. Y.

FOR RECORD FLIGHTS!

Power Your Models In This Summer's Contests With
Genuine MRL Special BROWN RUBBER!

ORDER NOW at these NEW LOW PRICES!

1/32"—35 ft. 5c—225 ft. 20c	1/8"—10 ft. 5c—225 ft. 60c
3/64"—25 ft. 5c—225 ft. 25c	9/64"—10 ft. 5c—225 ft. 70c
1/16"—20 ft. 5c—225 ft. 30c	5/32"—15 ft. 10c—225 ft. 75c
5/64"—20 ft. 5c—225 ft. 35c	11/64"—15 ft. 10c—225 ft. 85c
3/32"—15 ft. 5c—225 ft. 45c	3/16"—15 ft. 10c—225 ft. 90c
7/64"—15 ft. 5c—225 ft. 55c	1/4"—10 ft. 10c—225 ft. 1.10

These Prices Are POSTPAID! FREE LUBRICANT with Order!
SPECIAL BROWN RUBBER LUBRICANT
Medium tube—10c. 3 oz. can—30c. 8 oz. can—65c.

MRL MICROFILM SOLUTION

3 oz. can—30c. 8 oz. can—65c

MRL CONTEST CEMENT

Small tube—5c. Medium tube—10c. Large 3 oz. tube—30c.

CONTEST BUILDERS! ORDER EARLY!

ALL PRICES POSTPAID! No Orders Under 50c Accepted.

DEALERS! Write for NEW LOW Price List.

MODEL RESEARCH LABORATORY

3531W-N. WESTERN AVE., CHICAGO, ILLINOIS.

GAS ENGINES FOR MODEL AIRPLANES—BOATS

The G. H. Q. "Loutrel" Motor is most spectacular achievement in model airplane history—actually one of the most powerful motors ever constructed! Has broken records for amazing performance—flies model planes up to 10 ft. wing spread. Easy to start—just a twist of the wrist—and simple as A B C to assemble (So easy only a screw-driver is needed). Steady running (runs 27 minutes on ounce of gas). Cylinder and piston laped to within .0003. Kit includes plug, coil, condenser, tank, ignition wire, cylinder, piston, connecting rod, timer, crankshaft, all screws, nuts, bolts, etc. Every part is fully machined and finished.

No oil, gas, batteries or propeller included. Postpaid for only \$8.50.

Ready to run G. H. Q. "Loutrel" Motor complete with propeller block included; entirely assembled on stand. Tested and run before shipment. Performance guaranteed—1.5 Horsepower at 3000 to 7000 R. P. M.—No oil, gas or batteries included. Postpaid for only \$12.50. Send 5c for illustrated catalog including information on gas accessories and parts.

G. H. Q. MODEL AIRPLANE CO., 564-F Southern Blvd., New York N.Y.

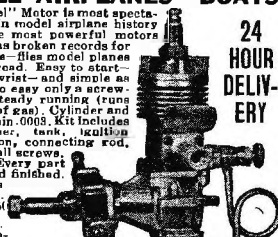

Bull complimented himself. "Der easy mark *du bist*, Herr Pingham. Hah!"

Phineas side-slipped a thousand feet, straightened out, then made a pass at the plummeting Pfalz. The Vickers expectationator would have rung a bell on a cuspidor if it had been tied to von Bull's right wing tip. The *Rittmeister* climbed, went into a loop, and thundered down on the Yank again. But his quarry was heading for the linoleum. Von Bull squinted through his goggles, saw that the prop of the Pinkham war bus was swinging idly. The motor had conked.

"*Gott mitt Uns*," von Bull chortled and dove. "*Sooch ein fightd!* Der guns get varmed oop, *nein*. Und down he goes by *der* Cherman side. Ho! ho! I gedt idt *der* dekorations from *der* Kaiser—*ja*."

Meanwhile Phineas was eyeing the terrain that was leaping at him. There was no sign of Jerry troops down there. It was one of those spots that Mars forgot to paint with his gory brush—a stretch of mosaic that did not fit into the schemes hatched up by Kraut brass hats. The flyer from Boonetown picked out a level stretch and swooped down. Von Bull's Pfalz was only fifty feet up when Phineas got out of the Spad's pit. Spandau slugs kicked up divots around him and he began to dance like a tenderfoot in a Klondike saloon.

"You dirty pig knuckle swiller!" he yipped, making a dive for a tree. He was crouched close to it when the *Rittmeister* strode up, a Luger very much in evidence in his right fist.

"*Wei Gehts!*" he mocked. "So! *Das ist* Pingham. So easy yedt, *ach!* How ist you shoodt all *der* odder Chermans down *mitt?* *Mitt der* dricks maybe, *ja?* Und where der dricks ist at, *Leutnant?* *Ach, der* gun you haff, *hein?* By *der* pocket maybe. Take idt from *der* pocket *mitt der* barrel, *Mein Herr*. Oddervise I shoodt. Keep away. Zee I hear how you gedt idt *der* odders *mitt der* drick gun, ha, budt me I am *der* smart feller. Efen vunce I don't gedt idt fooled. *Mach schnell, Schweinhund!* *Der* gun."

His prisoner did as he was told, removing the gun from his pocket and holding it by the barrel. He took three steps toward von Bull. "Boys, ain't you smart?" he breathed in mock awe.

The *Rittmeister* reached out.

SWO-O-O-O-OSH! A liquid fire hit him in the eyes. He let out a bellow and pulled the trigger of the Luger. But Phineas Pinkham went into his shortribs, head down. Von Bull lost all the ozone in his bellows and sat down hard. The tip of the Pinkham left ear was a little frazzled.

"That was close, oh, boys!" the resourceful Yank whipped out. He dragged the *Rittmeister* over to the Spad and dumped him to the sod. Von Bull stared into the barrel of his own gun when he got his lungs inflated once more.

"Git on that wing, you fathead!" Phineas ordered him. "Or I will ventilate your dome. Haw-w-w-w-w! My motor did not quit. And that was some gun. It fires backwards. There is a button on the end of the barrel that you

push—haw-w-w-w! The syringe on the inside of the barrel—git up on that wing, you bum, or I will shoot you in cold blood like I killed a Heinie yesterday."

"*Ach Himmel!*" whimpered von Bull, his eyes straying swiftly. But he got to the Spad's wing in a hurry when Phineas took aim with the Luger.

"A dead German brings more bounty," the Yank told him. "Guess I better shoot you anyways as—"

"*Nein, nein!*" gulped the *Rittmeister*. "Haff *der* mercy!"

A patrol of Heines reached the spot two minutes after the Spad was in the air. Phineas yelled: "You can jump now if you want to, von Bull, haw-w-w-w! It is only three thousand feet. Of course, if you don't land on your dome you will get hurt."

"*Donnervetter!*" swore the Kraut and he clung tenaciously to a strut.

The gas in the Pinkham Spad really gave out within three miles of Bar-Le-Duc. The flying wonder made a deadstick landing, sidewiped an apple tree, and deposited his prisoner fifty feet away in a ditch filled with oozy mud and water. Von Bull was fishing a little green frog out of his collar when his captor reached his side.

"*Gott im Himmel!*" gasped the *Rittmeister*. "*Besser ist der* bullet. Almost I gedt idt drowned by *der* untersea boadt und I join *der* air service. Und now I gedt idt drowned almost yooost *der* same. *Ach, der* Deffil you are."

Phineas grinned at the compliment as he took a coil of strong rope from his pocket. "I'm going to tie you up like New York traffic on Saturday night, von Bull, as you are my acquittal in a Yank courthouse. I will go to Barley Duck for a snort or two as do I need nourishment? Oof widderson. I will be back to get your corpse delecty this evening sometime. Make yourself comfortable the while."

PHINEAS did not quite reach Bar-Le-Duc before he met a very familiar friend. The ancient Rollo was skidding along the rough road on his empennage when Phineas first espied him. Then he let out a yip, twisted his torso double, and began digging his teeth into his right flank.

"Why, I see you still have company," observed the pooch's master by adoption. "Maybe it's Napoleon who is biting you. Or Madame Pompadour givin' you a dig, haw-w-w-w!"

Rollo seemed overjoyed to see Phineas Pinkham, his pal. His woebegone headlamps looked up at his master as if to say: "Have a heart! Get these walking pinchers off my carcass, will you?"

Phineas patted the pooch lovingly and pointed toward Bar-Le-Duc. "Follow me, old pal. I will get some flea exterminator from Babette. Come on, Rollo, shake a leg." Abruptly he stopped. His hand, groping down into a deep pocket, closed over something which he yanked out. In the light of day it turned out to be a dirty paper bag. "Now, Rollo, ain't this surprising? This is the stuff I put in Glad Tidings Goomer's biscuit flour only last Tuesday. It guarantees

to chase anythin' that crawls, up to an alligator. Let's get over here in the ditch, old boy, an' we'll apply the antidote. Ha, ya trust me, don't ya Rollo? Haw-w-w-w, nothin' else alive does. Now just stand still."

To Rollo the cure seemed worse than the fleas when Phineas rubbed the lotion into his scraggly hide. The pooch felt as if ten attacks of hives had decided to give him their entire attention. No sooner had he been decorated with the antidote than he put his tail between his legs, let out a yowl, and zoomed over a fence. Phineas stood still and watched the hound of many breeds disappear through the door of an apparently abandoned Frog hut a hundred yards away. Then he sat down to scratch his head.

"Huh," he exclaimed, "Rollo didn't seem to like it. Well if it don't kill the fleas, it will kill the pooch. Either way he won't suffer any more."

Phineas waited awhile. A strange sound that made his eardrums twitch ended his waiting. The disturbance seemed to come from the place where Rollo had sought shelter. He thought he heard somebody swear and he was sure about Rollo's indignant yelp. A moment later the pooch high-tailed it out of the place and ki-yied as though it had met the ghosts of its doubtful ancestors. Phineas whistled and Rollo whirled, skidding around on his caboose. The hound exhibited extreme pleasure about something despite the fact that someone had so recently given him a swift kick. Coming up to Phineas, Rollo sat down, tongue dangling and bellows working overtime.

"Why, Rollo, ya don't scratch any more," grinned his master. "Haw-w-w! Well, we chased them fleas all right. I bet Napoleon is lyin' in state some place. We did the trick, old boy, haw-w-w-w! Guess somebody lives there, huh?" Phineas jerked a thumb toward the Frog hut. Rollo gazed at him in sage silence after a brief "Woof!"

"Let's go on home, then," said the adventurer. "I got me a von to square things. Huh? You're hungry? Haw-w-w, I could eat a bone myself. We'll visit in Barley Duck first."

The pride of the Boonetown Pinkhams approached Bar-Le-Duc with caution. He managed to slip through the streets unnoticed and get into Babette's house. The French mademoiselle eyed him truculently with one dark glimmer. The other caressed a heavy pot that hung on a nail by the stove.

"Vous retournez, oui?" she shrilled. "More of ze trouble you have bring, non? Ze chien—outside you leave heem. Ze fleas—"

"Aw, they're all allezed," grinned her suitor. "The evidence is all washed up. Babette, I am trays hongree—so hongree I could manger ze cheval aussi some vaches. How about chow, huh? Boys, I weel marry vooze and take vooze back weeth me for jus' wan san'weech avec eggs and corned Willie."

"Oui—I geeve heem to vous. Ah, Pheenyas, you air ze—what you call zem—ze berrees, non? Ici, I geeve to

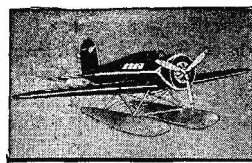

POST-ROGERS LOCKHEED
a 3 ft. Scale Craft Flyer—a fitting souvenir of these two great immortals... complete with aluminum cowl, carved prop, printed wood simplified plans, etc. . . . only \$1.50 plus 25c postage.

QUALITY FOREMOST

From the 48 States orders come to Heathcote. From Australia and New Zealand at the bottom of the world, from England, from far away Shanghai, model builders insist upon Heathcote Kits and supplies. With the whole world to choose from why is it that these builders buy from Heathcote. There can be but one answer... Heathcote quality cannot be duplicated at our lowest possible prices. Try us and see for yourself!

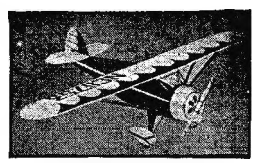

MONOCOQUE "145"
a 3 ft. Scale Craft Flyer: a model you would be proud to own... make this your next model... complete with aluminum cowl and carved prop, etc. . . . only \$1.25 plus 25c postage.

FREE!
A 6x8 photo of Wiley Post and Will Rogers taking off from Fairbanks, Alaska, on their fatal flight. The only company to secure these pictures. Given FREE with each 3 ft. Scale Craft Flyer.
AND AGAIN—FREE!
A brand new catalog is just off the press. Listing scores of Kits, Parts and Accessories. Your Free copy is awaiting you. Send for it today!

ATTENTION
With all orders post marked before July 15th... We will send FREE included with your other FREE GIFTS
1 Pursuit Machine Gun
1 Torpedo Bomb
ABSOLUTELY FREE
15' FLYERS 2 in 1 KIT
Here's a swell Kit! It brings exclamations of delight to every model builder. A FOKKER D-7 and CURTIS ROBIN... come with carved props. Both Kits for 59c.

GAS
MODEL BUILDERS
Here's what you've been waiting for... a catalog and handbook of Accessories for constructing record-breaking gas models. Written by champions. Contains gas model hints, photos of champions and their models, success stories of their championship flights. Free—but will appreciate 3c postage for handling!

If 36" lengths are desired, add double 13" price and add 10c extra postage to order.

18" BALSAs STRIPS
1/16x1/16 35-.05
1/16x1/8 20-.05
1/16x3/16 15-.05
3/32x3/32 18-.05
3/8x3/8 16-.05
1/8x3/16 12-.05
1/8x1/4 8-.05
3/16x3/16 8-.05
1/4x1/4 5-.05
1/2x1/2 2-.05

18" BALSAs SHEETS
1/64 x 2.4-.10
1/32 x 2.6-.10
1/16 x 2.6-.10
3/32 x 2.5-.10
1/8 x 2.4-.10
3/16 x 2.3-.10
1/4 x 2.3-.12
1/2 x 2.2-.15
(For 3"x18" double 2" width cost)

SHEET ALUMINUM
Prices per sq. ft.
.002 thick... .08
.005 thick... .10
.010 thick... .17

FREE!
With each \$1.00 order: 2 insignia sheets, 3 pair wheels, ass't carved prop up to 7". With each \$2.00 order: 250 ft. 1/4 flat rubber.

BALSAs PROPELLER BLOCKS
1/2 x 3/4 x 5 7-.05
3/4 x 3/4 x 7 7-.05
3/4 x 1 x 7 3-.05
3/4 x 1 x 8 2-.05
3/4 x 1 1/4 x 10 1-.04
3/4 x 1 1/2 x 12 1-.05
1 x 1 1/2 x 12 1-.07
1 x 1 1/2 x 15 1-.08

CELLULOID PANTS
3/4" to 1" Pair 1.18
1 1/2" to 1 3/4" 33

COLORLESS CEMENT
1 oz. .05 2 oz. .08
4 oz. .15 1 pt. .50

CLEAR DOPE OR BANANA OIL
1 oz. .05 2 oz. .07
4 oz. .13 1 pt. .45
Thinner same price as clear dope

JAPANESE TISSUE
White. per doz... .18
Colored, ass't., all colors... .20
Each... .05

SILVER TISSUE
20"x24" Ea. .65

TURNEED BALSAs WHEELS
Prices per pr.
1/2" .03 3/4" .04
1" .05 1 1/4" .07
1 1/2" .12 2" .20
3" .19 1 pt. .65

CELLULOID WHEELS
Prices per pr.
3/4" .05 1" .07
1 1/2" .10 1 3/4" .16

BAMBOO
1/16 sq. x 14 .35 for .05
1/16 x 1/4 x 11 1 for .01
1/16 x 1/4 x 11 1 doz for .07

RUBBER
1/32 sq. 30-.05
.045 sq. 20-.05
3/32 flat 20-.05
1/8 flat 17-.05
3/16 flat 12-.05

INSIGNIA SHEET
12 pr. and rudder and tail markings with gummed back. Each... .05

MODEL PINS
Pkg. of 100 .05

COLORLED DOPE
White, yellow, orange, blue, red, green, olive drab, black, silver, gold.
1 oz. .05 2 oz. .10
4 oz. .19 1 pt. .65

SUPER-FINE TISSUE
White Only
Sheet... .5c
Dozen... .50c

REED
1/32 or 1/16 6 ft. for .02
3/32 or 1/8 5 ft. for .02

THRUST BEARINGS
Small or large. 2c each, or 15c per doz.

DUMMY RADIAL ENGINES
Celluloid.
9 Cylinders.
1 1/2" diam... .18
2" diam... .23
3" diam... .34

ALUMINUM TUBING
Per Ft.
1/16 .09 3/32 .07
1/8 .07 1/4 .10

ALUMINUM LEAF
(.0003 of an inch in thickness, 3 1/2" wide).
5 feet for... .05

TURNEED HARD WOOD WHEELS
Per Pr.
1/2" .02 3/4" .03
1" .03 1 1/4" .05
1 1/2" .07 2" .10

18" BALSAs PLANKS
1" x 1" .10-.07
1" x 1 1/2" .10-.09

WASHERS
(1/2 or 3/4 dia.)
1 doz.01
1 gross10

WIRE
Straight Lengths Nos. 5, 6, 7, 8, 9, 10, 11, 12, 14, 15, or 16.
6 ft. for... .03

SANDPAPER
5 large sheets .05

DOWELS
1/16"x12" 1 doz. .06
1/8"x18" 6 for .05
3/16"x18" 4 for .05
1/4"x18" 3 for .05

HEATHE MODEL AIRPLANE CO. 438-F7 East 98th St. BROOKLYN, N. Y.

you ze kees."
"Haw-w-w-w!" chortled Phineas, his tongue in his cheek.

OVER at the Ninth Major Garrity was talking into the 'phone. "Huh—you say that Spad was found outside of Bar-Le-Duc? Out of gas, huh? The same Spad—huh? Nobody in it? Say, what's the idea? You kidding me? Listen, maybe I'm only a Major but even a Brigadier can't kid me. This morning, you said—what? I am, am I?" Why you—I resign so listen. You're a jug-headed, overstuffed—"

Six miles from Bar-Le-Duc a man wearing the uniform of a Major of Intelligence lay in the back seat of a car sleeping soundly. At the side of the road sat a corporal chewing on an oat straw.

"Huh, all las' night he slept an' all tuhday—the crackpot! He don't say where he's goin' so how can I take him there?" The dough was growling with disgust. "I sit here until the sap wakes up. This guerre is gettin' screwier by the minute."

Meanwhile, Phineas gorged himself on the fare offered by Babette, then indulged in a smoke. The girl sat on the

floor beside him, looking up into his face. It did not seem to bother her. "Ah—when we go over to ze *Etats Unis* we make heem ze beeg chateau avec ze garden. Aussi ze poissons d'or in ze beeg pool. An' we have six automobeels lak' you have geeve to me ze promeese. Ah, Pheenyas, c'est tres bon, non?"

"Non is right," her freckled swain agreed. "Ah—er—haw-w-w! I'm some kiddler! Anyways we'll have four hacks an'—" He swallowed hard and got up. "I must have been scalded when I told the dame that," he muttered to himself. "Boys, if Sadie Wilkins ever knew, she would bat my ears off. Gosh, what van blank makes me say them things easy. It's all her fault as she makes me drink it." He went to the window and looked out.

A big car was pulling up in front of an *estaminet* across the street. Two officers got out. One suddenly stopped and dug his fingers into the collar on his tunic. The other was twisted half around in an attempt to reach a shoulder blade with clawing fingers. Both men stopped, shook themselves, eyed each other. In the doorway of the Frog bar room they halted and made passes at various portions of their anatomy.

MOST IMITATED KITS ON THE MARKET!
20" HI-FLYERS • 50c EACH
 EACH POST PAID
 GUARANTEED TO FLY 500 FT.

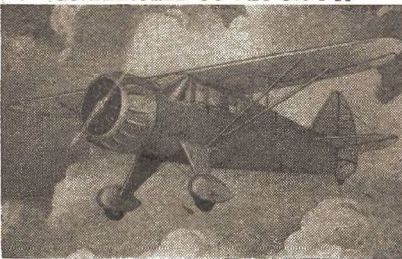

20" BENNY HOWARD'S "MR. MULLIGAN" 50c p.p.

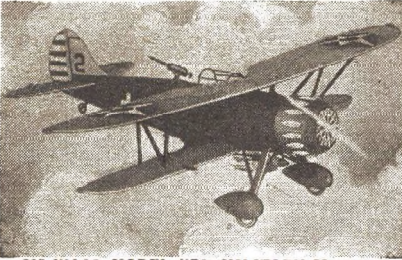

20" WACO MODEL "D" MILITARY 50c p.p.



20" FOKKER D-7 50c p.p.

SCIENTIFIC MODEL AIRPLANE CO.
 218-220 FT Market St., Newark, N.J.

Be Sure to Read
The SPECIAL OFFER to
FLYING ACES READERS
 on pages 86 and 90 of this issue

Meanwhile, the observant Phineas lent an ear to a small inner voice that was trying to make itself heard. Suddenly his lower jaw dropped as his thoughts travelled. Rollo had been driven out of that Frog hut by somebody. A determined boot had propelled the pooch into the open spaces—and that boot had not been worn by a spook. At that moment Phineas felt extreme regret that dogs cannot talk. The exterminator had driven Rollo's little aggravators out of his fur coat. And where had they found sanctuary? In somebody's clothes—uniform? Lieutenant Pinkham's brain flashed him a possible dazzling truth. He leaped away from the window and headed for the door.

"Attendez vous, Pheenyas!" yelled Babette. "Pourquoi you allez so queeck? Pheenyas!"

"Adoo!" the pilot flung back and was gone. Rollo fell into step with his master outside.

"Craze crackpot!" the light of love flung after their departing figures. "Lak' ze flea on ze chien ees he. Ici ees he—then ici he n'est pas—bah!" She picked up a chair and slammed it down again as if it were defacing Phineas' already homely countenance.

Phineas Pinkham walked into the *estaminet* as casually as if he were a member of the Yankee Flying Corps in good standing. The two officers who stood at the bar drew his attention. They seemed to be having quite a time with their drinking. They would take a gulp, then squirm as if the Frog brew had been filled with needles. First one glass, then another, would go down while the officers' fingers dug into various spots on their anatomies. Their con-

duct reminded Phineas of his first visit to a monkey cage in a zoo.

Suddenly a voice yelled: "Get him—arrest him! That's Lieutenant Pinkham!"

Three ugly M.P.'s surrounded Garrity's pet peeve but Phineas surprised them by making no move. In fact, he seemed pleased about it and every jaw in the place dropped limply.

"Just in time, haw-w-w-w!" he chuckled. "Git them two Heinions over there by the bar. The ones that are scratchin'. They're spies. Get the bums before—"

"Why—" one of the officers gulped, "he is crazy. We are American officers. We—" One stopped digging knuckles into his ribs. His face was as pale as the dicky of a penguin and he reached for a gun. Phineas picked up a bottle, tossed it quickly. It bounced off the man's pate and he went down with his eyes changing places. The M.P.'s ganged the other masquerader and tapped him into a state of coma. Then Phineas walked over and eyed something that was crawling up the neck of one of the prone men.

"Git me an empty bottle quick," he yelled. "It's the proof that they're Heinions. Huh, where are them Intelligence officers? It's lucky I happened in here or there would be more Yankee dumps blown up. It's always a Pinkham who has to come to the rescue. Hand me that bottle, you with the flat bugle."

"Don't git fresh with me," the M.P. cracked.

"Shut up or you will be busted," Phineas told him severely. "Now does anybody know where the professor is who trains the fleas, huh?"

A booming voice thundered: "Pinkham, you big lug! Step right out here; you're under arrest."

"Why it's Mister Garrity," remarked the object of the Major's wrath. "Fancy meeting you in a place like this. A bar-room. Tsk! tsk! tsk! Huh, and Bump Gillis and Captain Howell. I will report you to the Temperance—"

"You want to know where the professor is, do you?" stormed Garrity. "Well, he's waitin' out at the drome with a shotgun. If he ever gets a peek at Rollo—"

"Oh, yeah?" snapped Phineas. "Well Rollo is a hero. He'll get a crow *de guerre* instead of buckshot. He caught the Heinie spies. There they are, sittin' against the bar. Huh, Rollo unloaded his fleas on them. Haw-w-w-w-w! With my help. It was a dead give-away."

"Wha-a-a-a-a?" stammered the poor C.O. from deep down in his diaphragm. "You—Rollo—captured—they're the spies who are—why, don't you kid me, you fathead! I've been gettin' enough kiddin' the last twenty-four hours to—Arrest him! He's a deserter."

"Oh, yeah?" said Phineas with his favorite retort. "I was only out knockin' off the *Rittmeister* von Bull today an' gettin' the spies. Could you shoot me for that? Haw-w-w-w-w! Just ask Pershin'."

"You—you got von Bull—too?" Bump Gillis rasped in an extremely weak

1/4" SCALE KITS AT 25c EACH



BOEING 299 4-MOTOR BOMBER—\$1.50 Plus 20c Postage
 Kit comes with all wood parts cut out, lacquers, filler, fillet, cowls and all other necessary parts to make a perfect model.



22" MARTIN CLIPPER—\$1.50 Plus 20c Postage
 Kit comes with all wood parts cut out, lacquers, filler, fillet, cowls and all other necessary parts to make a perfect model.



10" VOUGHT BOMBER SUB I—25c



1/2" BOEING R26A SCALE—\$1.00

- 1/4" Scale Kits**
 contain cut to shape wood parts (body, wings, etc.), struts, cast prop-pilots—guns and individual motors where needed, rubber tired wheels, detailed plan, sandpaper, insignia, celluloid, cement, colored lacquers.
- 7-3/4" "Mr. Mulligan" 8" Chester Racer
 - 10" Kinner Navy Envoy 11" Vought Bomber
 - 7-3/4" Waco D. Pursuit 7-1/2" Boeing F4B-4
 - 7-1/2" Hawker S. Fury 6-3/4" Boeing P29
 - 9-3/4" Curtiss Falcon 10" Douglas 0-38
 - 8-1/2" Consolidated 7-7/8" Hawk P6-E
 - 8-1/2" Grumman 2-place 7-1/2" Northrop Fighter
 - 7" Grumman 1-place 11-1/4" Douglas Y-10-43
 - 7-7/8" Curtiss Goshawk 8" Chrome Fighter M-22
 - 6-3/4" Boeing P26A 8" Chrome Pursuit M-23
 - 8" Seversky 8L 8" Chrome Interceptor
 - 8" Heildiver 16-1/2" Chrome Bomber M-21
- 25c ea.** Plus 5c postage, except Bomber which is \$1.00 plus 15c postage. Any 4 except Bomber, \$1.00 plus 15c postage.

- Contain all cut to shape wood parts, finished cast prop., wheels, sandpapers, insignia, detailed plan, straightened steel flying wires, celluloid, turned cowls (where needed), brush, wood filler, fillet compound, 4 bottles lacquer, balsa motor, cement, aluminum tubing for exhaust, sight and guns, radiator screening, cockpit tubing, and special instruction sheet.
- 15-3/4" Hawk P6E
 - 15" Boeing F4B-4
 - 15" Boeing P26A
 - 15" Boeing P12-E
 - 13" Boeing P29
 - 15-3/4" Curtiss Goshawk
 - 14-1/2" Northrop Fighter FT-1
 - 14" Grumman Fighter F2F-1
 - 15-1/2" Waco D. Pursuit
 - 15" Hawker S. Fury
 - 12" Vultee Attack
- \$1.00 ea.** plus 15c postage

LEWIS MODEL AIRCRAFT, 2210 W Lombard Ave., Berwyn, Ill.
DEALERS! WRITE FOR LATEST PRICE LIST AND DISCOUNTS ON NEW KITS, CASTINGS, CELL. MOTORS, PAULOWINA PROPS, ETC.

voice. "Wh-where is he?"

"Oh, I got him in storage," replied the hero of the moment from the heights of superiority. "I will deliver him on the hoof in due time. Now somebody go over an' git Professor Marsellaise, or whatever his moniker is. Tell him if he will come very fast, he will git his flea circus back. Haw-w-w!"

WHILE a car rocketed at full speed toward the Yankee drome, Phineas Pinkham sat down near Rollo and enjoyed the limelight. "That's the way it happened," he rambled on with his tale. "I was walkin' toward Bar-Le-Duc with Rollo. I put somethin' on him that made his hide sting and he made that Frog hut in four jumps. Pretty soon he come out yippin' as somebody—one of them fake Yankee brass hats—kicked him in the slats. But I saw Rollo didn't have the fleas any more, so me and him come in here to Barley Duck as we was hungry. I was eatin' chow in Ba—er—my dame's house when I saw these tomaters get out of the car in front of here. They looked like something was bitin' 'em all over as they was digging into their fuselages. Haw-w-w-w-w!"

He paused to gloat over his prisoners. "Well, I says, why would two officers be hidin' in that Frog hut if they was the real McCoys? An on the other hand, a lot could be seen from there by a couple of Krauts packing field glasses. I says how could fleas leave Rollo so fast and climb up into their torsos? Because, I figure out, the fleas come out of their dugouts under the pooch's hide in a hurry when the exterminator sank in. They jumped off Rollo—ever see them fleas jump, sir?"

Garrity shook his head.

"They jumped into the uniforms the spies was changing into, that's what," Phineas guessed proudly. "I bet there is two real U. S. Intelligence men tied up over in that place. They're probably the two Monk Flanagan was looking for near Thieblemont. He didn't git there, so they went out lookin' for him and got caught by the spies. I bet I'm right." The prisoners were too dazed by the massaging their heads had had to deny anything Phineas said. One even nodded and jerked out "Himmel!"

"Why didn't Flanagan get there?" Major Garrity wanted to know.

"Why Major? I don't know everything," replied Phineas innocently. "Why, if I did, I would be a general, or—"

"I give up," sighed the Old Man. "Go on."

"Well," the flyer who had talked himself out of many a situation went on, "I bet Monk—er—Major Flanagan is drunk somewheres as he is the biggest grog hoister since—"

"Listen here, Pinkham," a Brigadier blurted, "you're talking about your superiors. You—" An M.P. came in then and saluted. He had a scared looking corporal behind him. The M.P. said the dough wanted to speak to the Brigadier. "Well," growled the brass hat, "let him."

"I—er—sir," stuttered the dough, "I—er just drove an officer in here. I

th-think he-he might be dead. He's been out cold since yesterday. He didn't tell me where to drive him before he fell asleep, an' I been waitin' out there about six miles for him to wake up. But, I says, I better drive him in to Barley Duck an'—"

Phineas Pinkham gazed at the ceiling with interest. Major Rufus Garrity looked at Pinkham. Everybody else went outside to see who was in the car. Finally Phineas and his C.O. went out, too. It was Monk Flanagan and no mistake. He stirred a bit when the Brigadier reached into the car and shook him. Finally Flanagan yawned so wide it seemed as if he would split his head open. He blinked, rubbed his eyes, blinked again.

"Where am I?" he forced out over a tongue that was as thick as a piece of tripe. "Who—what—?"

His arch enemy, Lieutenant Pinkham, pointed to a bottle in the seat beside Flanagan. "I told you he was oiled," he announced.

"So! Drunk on duty, are you?" the brass hat yelped. "And those spies—get him out of there and put him in the klink. I'll break this guy wide open."

"Fool with me, will ya?" Phineas said under his breath.

"What'd you say?" barked Garrity.

"Oh, I must've been gathering wool for my next overcoat," countered the freckle-faced pilot. "Haw-w-w-w-w! If you'll excuse me, I will borrow a car and go out to pick up my Von. He's kind of expectin' me. I need the *Rittmeister* to own up to them loaded wienies that blew up the groundhogs' kitchen! And maybe there are two officers tied up in that Frog hut."

Before Phineas and Major Garrity got into a car, Professor Rene de la Bouillaise barged into town. He was all agog as he ran into the *estaminet* with a glass jar in his hand.

"Ah—zere ees Napoleon!" chortled the flea trainer joyously. "Come to Papa, Danton—don' you run away, Lafayette. *Sacre! Ah, merci beaucoup*, ever'bodee. You tak' off ze clothes from ze *hommes*. Six leetle fleas zey are miss'. *Mon Dieu*, if Madame la Pompadour she is *tres mort*, I sue ze *armee* of ze *Etats Unis*. *Voila! Discardez* ze clothes! I mus' fin' Madame—"

"Let's *allez*," proposed Phineas. "We got those errands to do, Major, Haw-w-w-w-w! Did you hear somethin' sir?"

It was Monk Flanagan's bull-like voice. Between two burly M.P.'s he was being roughly escorted to the nearest klink. The sight of Phineas Pinkham had driven him gaga.

"You done this to me, you fresh yap. I'll get you yet. Monk Flanagan never forgets—when I git out of this—"

"Gr-r-r-r-r! Yurp—yurp!" said Rollo.

"Don't you bite him, Rollo," Phineas cautioned his mutt. "Come away from Monk. D'you want to git hydrophobia? Haw-w-w-w!"

"I'll git hunk! You planted that bottle on Gillis. You had it all—"

"Tell it to the Judge, Major Flanagan!" Phineas called after him. "Come on, Rollo. Here Rollo!"

ONE DAY SERVICE

—ON—

FINISHED SOLID SCALE MODELS

Ready built models complete in all details with wire rigging, insignias, RUBBER TIRED WHEELS, license numbers and machine guns when needed, finished in colored lacquers and MOVABLE CONTROLS (but not from the cockpit). All orders sent postpaid and insured.



(Upper Left) 8 1/4" Waco Cabin, \$2.25—(Upper Right) 9" Consolidated P-30, \$2.30—(2nd Row Left) 3 1/4" Aeronca, \$1.80—(2nd Row Right) 11" L.V.G. 2-Seater, \$2.50—(3rd Row Left) 7 1/4" Curtiss Hawk P-6E, \$2.05—(3rd Row Right) 7 1/4" Pfalz D. 3, \$1.80—(Bottom Left) 8 1/4" Sopwith Snipe, \$1.80—(Bottom Right) D.11.4 2-Seater, \$2.50.

19" Friedrichshagen or Gotha Bomber\$7.50
26" Handley Page Bomber10.00
17 1/2" Martin Bomber7.50
26" Boeing Bomber "299" (Flying Fortress)10.00

7 3/4" Boeing F4B-4	..\$2.05	8" Monocoupe\$2.05
6 3/4" Boeing P-26A	..2.05	7 1/4" Northrop Fighter	2.05
7" Grumman Fighter	..2.05	11" Stinson Reliant	..3.00
9" Hawker Fury Mono.	2.30	8 3/4" Vought V. 65	..2.50
10" Lockheed Vega	..3.00	9 1/4" Vultee Attack	..2.40

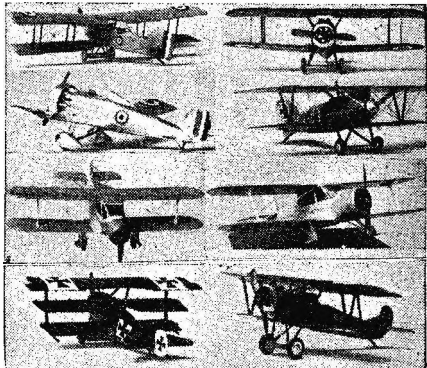

(Upper left) 11" Breguet, \$3.00—(Upper right) 7" Camel, \$1.80—(2nd row left) Vickers Jockey, \$1.80—(2nd row right) Albatros D. 3, \$1.80—(3rd row) Two views of an 8 1/2" Beechcraft B17L, \$2.25—(Bottom left) 8 1/4" Pokker Triplane, \$1.80—(Bottom right) Pokker D. 7-7 3/4", \$1.80.

6 3/4" Bristol Fighter	..\$2.50	7" Pfalz Triplane\$1.80
6 1/4" D. H. 51.80	6 1/4" S.E. 51.80
6 3/4" Nieuport 171.80	8 1/4" Spad 131.80
6 3/4" Nieuport 281.80	5 3/4" Westland Wagtail	1.80

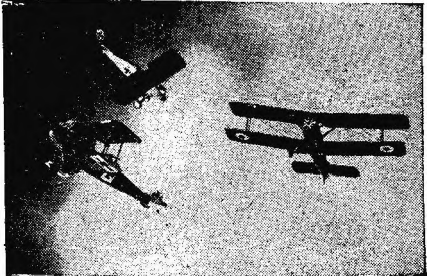

"INTERFERENCE"

A German Rumpler 2-Seater and a British Sopwith 1 1/2 Strutter 2-Seater are having a "private" battle when in the above photograph (actual photo of the models posed)—a German Pfalz D.3 joins in on the fray. 10" Rumpler, \$2.50—8 1/4" Sopwith 1 1/2" Strutter, \$2.50—7 1/4" Pfalz D.3, \$1.80.

CHRISTIE BATLAS

P. O. Box 160-B-3

Morgantown, W. Va.

Citations and Awards of the Flying Aces Club

(Continued from page 56)

to the following members of G-2 for exceptional services to the club:

- | | |
|------------------------|------------------|
| Robert Nice | John Paolantonio |
| Frank Ylizationalturri | Benjamin Surdi |
| Bob Feik | Edward Farrell |
| Matt Weedon | Floyd Witten |
| H. J. Oursler | Charles Scott |
| Chester Graden | Florence Matulis |
| Emanuel Taylor | Saul Finegold |
| Laurabelle McCain | George Watkins |

The following winners of the Distinguished Service Medal of the Flying Aces Club have been given the first award of the bronze props for additional services to the club:

- | | |
|-------------------|----------------|
| Sherman R. Higdon | George Hassen |
| Winthrop Difford | Milton Weglein |
| Denny Hobbs | Audrea Hoehle |
| Edwin A. Ohler | Anthony Buczko |
| Roland DiMasi | Thomas Mones |

The following winners of the first award of the bronze props have been given the second award of the bronze props for additional services to the club:

- | | |
|-----------------|---------------|
| Philip Varker | Walter Baylis |
| Roger Pendleton | Walter Joseph |

The following winners of the second award of the bronze props have been given the third award of the bronze

props for additional services to the club:

- | | |
|-----------------|----------------|
| Joel Bell | Francis Holmes |
| Leonard Carrion | |

The following members of G-2 of the Flying Aces Club have been awarded the silver F.A.C. ring for exceptional service to the Club:

- | | |
|-----------------|---------------|
| J. A. McDermott | David Score |
| M. H. Eisele | Geraldine Pyl |
| Walter Allen | |

The following members of G-2, of the Flying Aces Club, have been awarded pocket knives for exceptional services to the Club:

- | | |
|-----------------|--------------------|
| Nat Fleischer | George Marvin |
| John S. McArdle | Charles E. Geeting |

The following members of G-2, of the Flying Aces Club, have been awarded Aviator's Identification Bracelets for additional services to the Club:

- | | |
|------------------|----------------|
| Paul R. Guerrero | Donald Hopkins |
|------------------|----------------|

The following members of G-2 have been cited by the Flying Aces Club for exceptional services to the club and are being considered for the Distinguished Service Medal:

- | | |
|-------------------|-------------------|
| E. W. Putney, Jr. | J. A. Eckert, 3rd |
| John Crowley | Dayton Brown |
| Fred J. Helmick | Edward Nolan |
| Chester X. Mroz | Albert Caltune |

Cunning of the Camera Hawk

(Continued from page 26)

over that slowed his speed and the American shot by without touching his fire trip. Then the Kawasaki struck with all its guns blazing simultaneously. Sleeting sheets of death raged around Harvey Mason. His foe was striving by every trick in his ken to send him down in flames.

Gunning his own craft to its highest power, Mason maneuvered with dazzling speed. He looped, side-slipped, twisted. Then, when the Kawasaki was blazing at him with every gun, he spun sharply and his Brownings cracked out a short, savage drag. The parallel line of his tracers leaped out to catch Yomamoto's whirling prop. Next they barged into the laboring motor. The American checked their fire before they ranged back into the cockpit. He had no intention of killing his adversary.

Whirling away, Mason circled. Yomamoto was fighting desperately with his controls. The Kawasaki's nose dropped and for a moment the wings spun in a circle. Then the Eastern plane straightened into a glide and headed for the water. The American watched his foe signal with his radio. The prow of the sealing schooner turned. The white foam in its wake told that it was supplied

Everybody's wild about these great

BARGAIN BUYS!



Big 20" G-D Rep Flying Models at half the price of similar models

Each Kit an amazing value—with printed out wood, super-detailed drawings, finished scale wood wheels, real G-D model airplane rubber—everything—EXCEPT LIQUIDS

14-cylinder Hughes Racer

In realism, flying qualities and completeness of detail, these big 20" REP (Representative-Duration) beauties surpass many Kits costing twice and three times as much. Only a limited number of each model is being manufactured, SO ACT QUICK! If your dealer can't supply you, order direct—by check or money order (no C. O. D.'s). Rush 3c stamp for complete catalog.

DEALERS: Wire or Write

Cleveland Model & Supply Co., Inc.
1866FA West 57th Street, Cleveland, Ohio, U. S. A.

More New Summer Kit Hits!

Kit R53, Grumman F2F-1 Fighter, 50c; Kit RX5001, Cleveland Amphibian, 60c; Kit RX-5002, Cleveland Pirate Bomber, 60c; Kit R-52, "Mister Mulligan," 50c; Kit R21, Hawk P6-E, 50c; Kit R15, Fokker D-7, 50c; Kit R54, Hughes Racer, 75c; Kit R56, Consolidated A-11, 40c. No postage charge. (English, Canadian and Mexican customers: add 10%; all others 20%.) Also ready: Mr. Mulligan in 1/8" at 50c and 3/8" scales at \$2.95.

— FREE —

The Next Two Issues of Flying Aces!

HERE'S great news—FLYING ACES declares a "dividend"! Because we want to make sure that YOU do not miss a single issue of FLYING ACES, we've decided to make a special limited offer of nine issues for \$1.00. At 15c a copy, a dollar's worth of FLYING ACES, bought on the newsstand, would be roughly seven issues. Nine issues would cost you \$1.35. Therefore, in "knocking off" the 35c you can readily see that we're giving you two issues absolutely free.

We suggest that you take advantage of this offer at once since it represents a real bargain. You know that the new 96-page FLYING ACES offers more than any other magazine in its field; that it is really THREE MAGAZINES IN ONE—a Model Building Magazine, an Aviation Fact Magazine, and an Aviation Fiction Magazine—all bound up in one cover at less than the cost of any one aviation magazine. Assure yourself of its large and unequalled model building department, its thrilling stories, interesting features, rare photographs and valuable data for your aviation scrapbooks, for the next nine months by filling out the coupon right now.

THIS OFFER DOES NOT INCLUDE F.A.C. RING OR BRACELET

GOOD ONLY IN U. S. AND POSSESSIONS

Subscription Dept., FLYING ACES, 67 W. 44th St., New York City.
Gentlemen:

I want those two free issues! In other words put me down for that nine months' offer, for which I enclose \$1.00, and start my subscription with issue.

Name

Street and No.

City and State

with an engine unusually powerful for a peaceful craft of its type.

A glance toward Seal Island, far to the North and West. A triangle of dots was forming. Commander Jacobson would soon be roaring toward the scene of combat. Mason had wilfully disobeyed orders. He knew what the result would be. He put his ship into a sharper glide as Yomomato neared the water.

Next they were both bobbing on the surface. The American taxied alongside the Japanese. Yomomato was standing in his cockpit, a Luger automatic pistol in his hand. Mason nosed to where his Brownings would bear on the Kawasaki.

"Drop that gun or I'll blast you," he shouted.

A mirthless smile from his adversary, but the pistol was thrown overboard. Then Mason drew up to where he could clamber from one ship to the other. His service Colt was in his hand.

"Get out on the wing," he ordered.

Yomomato hesitated, but the sharp click of a downthrust safety catch sped his steps. Mason reached into the Kawasaki pit, took a roll of film from the floor camera. Then he searched a small locker beside it and removed two cylinders of exposed film.

"I guess that's all," he growled.

"I guess—not all," Yomomato smiled and pointed to a triangle of scout planes piquing for the water. "Commander Jacobson will have something to say. I am sorry for you."

"That's what you said after you put emery in my cylinders at Los Angeles," Mason retorted.

It was a shot in the dark, but the tightening of Yomomato's eyelids told it was bullseye. Again the man smiled with that hissing intake of breath traditional among his people.

"Not emery, my friend, but carborundum," he corrected, "Carborundum much harder, cut more deeper than emery."

Mason's glacial blue eyes looked into those dark, almond lidded orbs. Each face was inscrutable to the other. Yomomato's impudent admission of his trickery at the air races only hardened Mason's grim face.

"Okay, buddie," he said, "You're going to need something still harder to get out of this."

The Oriental's smile widened. Then his eyes flicked to the descending American planes.

"Commander Jacobson will take care of that," he half hissed, "and unless very badly mistaken, you, my friend, will—"

THE rest of his words were drowned by the American squadron leader's motor as he taxied alongside. Jacobson rode in a fast two seater piloted by a junior officer. He examined the broken prop and damaged motor of the Kawasaki. Then he stepped onto Yomomato's pontoons and saluted.

"Please accept my apologies for this regrettable incident," he said in formal tone, "I need scarcely say that Ensign Mason not only exceeded his authority,

but flagrantly disobeyed instructions."

Yomomato bowed and smiled. He had heard Jacobson's orders, but in the tricky game of international relations, admission of knowledge is taboo.

"He tried his best to crash me," Mason flamed.

Yomomato's smile widened. He gestured to the American ship.

"You find no bullet holes, I think," he said.

Mason's bleak face flushed.

"Thanks to your poor gunnery—or my ability to dodge," he shot back, "How about your pictures—of the islands?"

Once more the other man bowed. He turned to Commander Jacobson, his ivory tinted face crinkled with what was intended to be his frankest smile. At the same time he gestured to the sealing schooner.

"My government detail me to aid seal fisher," he began. "Picture taken to show where seal swim. Please investigate and confirm."

Commander Jacobson nodded. Then he turned to Harvey Mason.

"You will consider yourself under arrest," he said, "Fly back to the base. I'll see you when I return."

"Aye-aye, sir."

A jerk at the inertia starter and Mason's motor roared again. He taxied through the bobbing ships of his formation, then took to the air. Half an hour later he was down, striding toward the photographic room with two rolls of film in his hand. He had flown away before Yomomato could ask for them. He would soon find out if Yomomato had spoken the truth.

He waited impatiently for Jacobson's return, pacing back and forth in his room. His disobedience to orders might result in an international incident that in turn might lead to war. The peace of the Pacific was on tenterhooks and anything might ignite the powder. Jacobson had followed orders in commanding him to withhold fire. Upon his shoulders would fall the whole blame.

Two hours later the squadron returned, but the commander did not summon Mason immediately. Instead he prepared a long radio dispatch for the admiral commanding the Pacific Fleet.

The short summer night of the North descended and Mason continued to pace up and down his room. He was certain Yomomato would make another attempt to photograph the Seal Island base. If the pseudo sealing schooner carried an extra motor and prop, the effort would be made immediately. Meantime, the pilot waited breathless for a report on the films and a summons into Commander Jacobson's presence, but no word came.

A few hours of sleep and Mason was on his feet again. After Yomomato's cool confession of his trickery at the Los Angeles races, he was prepared for anything. He wondered what Jacobson would say when he told him of that admission. Once more he paced back and forth in his room.

Finally, an orderly appeared to inform him that the squadron leader would see him, and he hurried into

We're making a test: Shall WE pay the postage or leave it to you? Your response to this ad will guide our future policy. Buy a BURD now! You get the finest values in the field, and WE PAY THE POSTAGE!

POSTPAID!

30-
in! **50¢** No
Complete Extra
Charges!

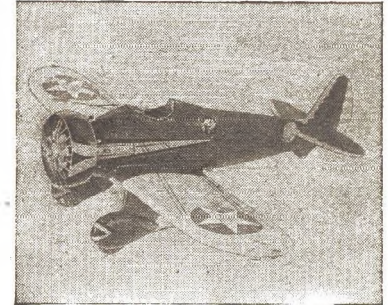

30-in. BOEING P26A, 50c Postpaid

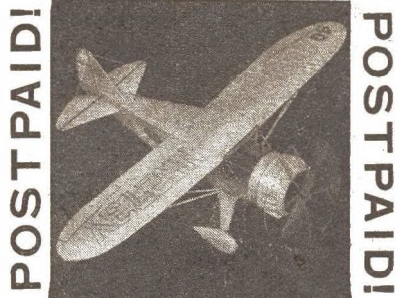

30-in. MR. MULLIGAN, 50c



30-in. DOUGLAS OBSERVATION, 50c Postpaid

BURD MODEL AIRPLANE CO.
330 Park Ave., Baltimore, Md., Dept. F.U.L.

ORDER NOW!

DISTRIBUTORS WANTED

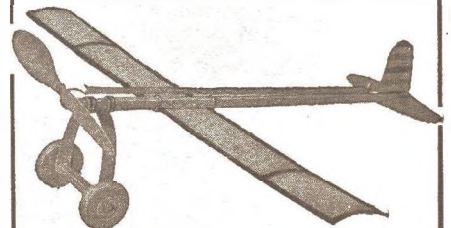

READY-TO-FLY 10c RETAIL

Hundreds of thousands of these ready-built, Guaranteed-to-fly R.O.G.'s have been sold; and millions more will be sold by wide-awake jobbers and dealers who answer this ad. Flies 100 to 150 feet consistently. Crash-proof. Write, on your business letterhead, for low wholesale prices. Sample dozen \$1.00 postpaid. Less than one dozen not sold. No C.O.D.'s, no free samples.

WESTERN AIRCRAFT MFG. CO.
1269 S. Norton Ave. Los Angeles

BIG MONEY! ASSEMBLING MEAD'S NEW Portable OUTBOARD BOAT!

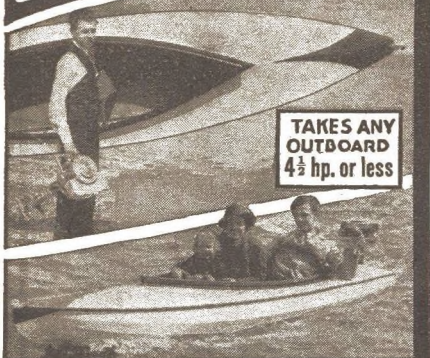

OK-2 is strong as a giant Yet Weighs only 50-Lbs!

PRICED LOW!
and PAY AS YOU BUILD

A Sensational Build this 50-lb., tough, durable, sea-worthy, Portable Outboard Ki-Yak in 2 days at home! Then it's always ready to go anywhere by hand or car. Safe, leak-proof. More speed per horsepower. More miles per gallon! Mead's perfected aluminum-ribbed Cut-to-Fit Construction Kit guarantees successful assembly, easily, quickly—and profitably (if you build to sell to others). Amazing LOW Introductory Prices, and if you wish you can even Pay as You Build! OK-2 also available FACTORY-ASSEMBLED! RUSH dime and Coupon below, for details!

WEIGHS only 50 LBS! Ideal for Auto Tourists!

9 HOURS TO BUILD NEW SPORTSMAN'S BOAT!
for FISHING CAMPING HUNTING SAILING

\$600 PADDLE GIVEN
with your Ki-Yak —if you hurry!

"CK-2" PADDLE BOAT
Quickly Converted Into SPEEDYSAILBOAT
Assemble Mead's "CK" Sportsman's Ki-Yak (paddle and sailboat) in 2/3 LESS time with new construction principle. "Home Assembly" saves you nearly HALF factory-built cost! Most sensational boat development in years! Weighs only 60 lbs.—Portable by hand or car! Thousands in use! "CK-2" also available FACTORY-ASSEMBLED! RUSH dime (covering handling, postage) and Coupon for giant New Colored Circular. Low Introductory Prices. \$8.00 Gift Paddle Offer. Hurry!

MEAD GLIDERS
15 South Market St. Dept. FA7 Chicago

MAIL COUPON NOW!
Gentlemen: I am enclosing 10c postage, handling charge. Please rush me your New Boat Catalog, Low Introductory Prices and \$8 Gift Paddle Offer. (Please Print Plainly)

NAME
STREET & NO.
CITY STATE
RUSH ME WITH 10c TO:

MEAD GLIDERS
15 S. MARKET DEPT. FA7 CHICAGO, U.S.A.

Jacobson's presence. The commander held a long radiogram in his hand, but laid it aside when Mason saluted. His face was stern, his eyes cold.

"MASON," he began in measured tone, "Not only have you involved our country in an ugly incident, but you have been barking up the wrong tree. Two mistakes do not make a correct guess."

"Wrong tree?"
"Yes. The plane that you shot down yesterday was acting in a purely scientific capacity aiding pelagic fishing vessels. On the other hand, we have reason to believe that Soviet ships are massing off Kamchatka preparing for a thorough survey of this island chain."

Mason's face hardened. "I'm sorry, sir," he said, "but I am afraid you are mistaken."

The squadron commander looked up, his cheeks purpling. Then he turned to extensive notes he had made during his interview with Yomomato.

"For your information," he said in a coldly level voice, "A formation of Soviet planes is expected to appear over the islands within the next hour. The 'ears' have already picked up their motors."

Mason stiffened to rigid attention. Invasion of a squadron of military ships could only have one result—action.

"May I go with you, sir?" he asked.
The commander stared at him incredulously for a moment. Then he took up the long radiogram he had been reading when the pilot entered.

"No—not until the admiral has decided on your case. You will remain under arrest, but not in duress. However, you are grounded until—until Washington is heard from. Meantime—"

Jacobson paused as an orderly hurriedly entered the office. The man's face was flushed with excitement. He gestured toward the ceiling.

"They're coming, sir," he announced, "Lieutenant Evans wants to know if you're planning on hopping and—"

"Yes—tell him I'm coming right away."

The commander shoved back his chair, strode across the room.

"Please, sir—can't I—"

"Sorry, Mason, orders are orders."
From the landing field came the roar of engines. The Scouts were taking the air. About the huge mechanical ears several field officers milled. There was a distinct note of excitement in the air as possibilities of war between the Soviets and America were bandied back and forth.

Harvey Mason elbowed his way through the press and studied the sound track. The ink-fed stylus was making a strange pattern upon the paper ribbon that passed beneath it.

"The Russkies use M-17 engines—Soviet-built B.M.W.'s—don't they?" he asked of the officer in charge of the apparatus.

The man nodded, looked at the sound track once more. A puzzled frown gathered between his brows. Then he began swinging the giant "ears," trying to segregate one motor from the wave of

sound sent out by the full squadron. Gradually, a distinct pattern appeared. Mason's blue eyes hardened when he appraised it.

"Looks like Mitsubishi-Jaguar to me," he said.

"Yes, but—"

"Swing around and see if you can't get a solo—off that way," Mason gestured in the direction where he had forced Yozuki Yomomato down.

Once more the man nodded, turned the "ears" toward the South and East. At the same time, a similar device at the other end of Seal Island, swept its huge, phonograph-like horns in the same direction. The two detectors, with a base line of three miles between them, could record accurately the distance traveled by the sound that reached their finely tuned microphones.

A new pattern appeared under the point of the stylus! It was familiar to Harvey Mason and he felt his blood pounding at his temples. The supposed squadron of Soviet planes was far to the North. It was flying more than twenty miles from the nearest of the Aleutians and was violating no territory by sweeping over the high seas. But its presence had drawn Commander Jacobson and his full complement of Scout planes into a sector far removed from Seal Island. And now a lone plane was roaring toward the air base, its pilot confident he could take numberless photographs without danger of attack!

"I've got to stop that fellow," Mason said to the officer in charge of the anti-aircraft guns.

"But you're grounded."

"I may be as far as orders are concerned, but I'm not going to let Yomomato get his pictures even if they bilge me."

"That's what they'll do if—"

"You keep track of your 'ears.' I may need them."

MASON hurried to where his plane was bobbing beside the sea ramp. He waved aside mechanics who rushed to his aid. He was openly disobeying the orders and he did not want to involve other officers or enlisted men. Next he was in the air, hanging his little ship on its prop and mounting with throttle wide-open. A few words into the radiophone and he got bearings that gave the altitude and position of the ship that was sweeping toward Seal Island. He climbed until he reached that level, then switched on both muffler and direction finder. The rhythmic beat of a Mitsubishi-Jaguar motor came into his ears. He nosed in its direction.

Gunning at the highest speed possible with muffler cut in, the tiny Scout clove the air at well over two hundred miles an hour. Mason swept the sky ahead with his highest power field glasses. He caught the sight of outspread wings. Then he stiffened in his seat. Instead of bearing the rising sun insignia of the Chrysanthemum Empire, he saw the red star of the Soviets! His lips tightened and a frown plowed its way between his brows. His logic had been at fault. He had expected to find Yomomato. Then his ears caught the beat of the Mit-

subishi-Jaguar once more and his tightly held lips relaxed into a smile. Paint would camouflage any ship, but the rhythm of a motor is always the same. He snapped cartridges into both Brownings, loaded his one-pounder, and cut off the muffler. He wanted every ounce of power his engine could develop.

This time he had no orders to withhold his fire. He had violated all commands. He peered through his telescopic sights as the camouflaged plane raced toward him. He centered on the pilot's cubby. Before, Yomomato had worn no masking goggles, but now, even with a change in uniform and helmet and plane painted after the fashion of the Soviets, Harvey Mason knew he was again facing his rival of the air races at Los Angeles.

He pressed his fire trip and a blast shot from his Brownings. Then he signalled the pilot to fly away from Seal Island. The man shifted his course, but made no effort to turn back. Another blast from the Brownings and a pantomime to wheel or face a consequences. Yomomato's teeth were now bared in a mirthless smile. He trimmed his tail and swept straight toward Seal Island under full power!

Harvey Mason shoved his throttle to its limit and the Scout leaped like a frightened thing. Burning up the air with its speed, he was on Yomomato's tail in less than a minute. Then his Brownings jabbered.

The Oriental swept up into a loop, came down with Vickers guns flaming. His one pounder blasted and a cone of shrapnel broke, its flying fragments ripping into the Scout's wings and fuselage. Yomomato was striving desperately to crash him. Mason sensed the man's strategy. The flight of supposed Soviet planes was a decoy to get Commander Jacobson and his pilots away from Seal Island. They, too, were undoubtedly repainted Kawasakis! The squadron leader would recognize them as quickly as they came in sight. He could do nothing. The formation would now be cruising over the high seas, far from the twelve mile limit. Jacobson could merely observe, then wheel and go home. Meantime, Yomomato would get his photographs—unless he was brought down.

And now, Mason knew that Yomomato was striving by every possible means to kill him. A tornado of fire poured from his guns. To hesitate would be to court destruction. Mason pulled up in a zoom that shot him above his adversary. A half circle and he tossed his tail into the air. Diving like a falcon, he roared down on the disguised Kawasaki and fired a withering blast that ripped its tail, destroyed all empennage controls. He saw it stagger, fall off drunkenly.

But Mason's troubles were not yet over! For as he slid to one side, Yomomato, even though riding a ship that lurched and bucked like an outlaw horse—got him in the sights for one fatal moment. A flame darted from the Kawasaki's prop hub, there was a sickening thud, an explosive burst of light, and Mason's right wing tore off at the root!

Mason was stunned by the awful blow, but as the Scout nosed down he

Boys BUILD THIS

CAPE COD COTTAGE

\$1



Send NO MONEY
A Practical Gift

WE FURNISH EVERYTHING to build this *authentic* model; 100 ft. lumber, roofing, nails, glass, glue, rule, saw. Step-by-step instruction plan, *easily* followed. 11x12x18." Ideal project for manual training. Fascinating and a challenge to your skill. Amazing value. Pay postman \$1 and 25c. C. O. D. fee or if you prefer send \$1 and 15c postage. Satisfaction guaranteed or money back.

MINIATURE HOMES CO., 127 Greg Avenue, Mt. Carmel, Conn.

managed, half unconsciously, to hurl himself from his pit. For an instant, his feet slithered over the left wing, then he fell free.

A moment later, he pulled his ripcord, hung from the silk. Now Yomomato was left to frantically fight his controls—but his ship likewise was doomed. As it hurtled down, blasted tail surfaces fluttering in the slipstream, Yosuki Yomomato, too, was obliged to bail out.

Mason watched from his swinging seat high in the air. Yomomato was drifting his chute toward Seal Island! Mason worked his own shrouds, slipped sidewise in an effort to follow him. Then he saw flashes of light from Yomomato's hand. The man was firing at him with a Luger, attempting to kill him.

Mason drew his Colt from its holster, but this gesture failed to deter the Oriental. Yomomato was a Samurai. Though beaten in combat, he would die fighting. The high whine of his bullets continued to break around the American. One slug cut one of his parachute shrouds. Another raked the sleeve of his fur-lined flying suit. The Oriental was showing remarkable marksmanship.

"If he keeps this up, I'll have to do something," Harvey mumbled.

But then, out of the North came the roar of many motors. Harvey Mason looked around. Triple-V's of fast Scout planes were racing toward Seal Island with Commander Jacobson's biplane at their point. Yosuki Yomomato's almond eyes also turned in that direction. They saw and understood. The pencil-like muzzle of the Luger was raised to his right temple. A flash of fire and the body hanging in the parachute harness went limp. Yomomato had followed the samurai's path to its ultimate conclusion. *Bushido*, the soldier's way, had been his end.

The parachutes drifted lower. Commander Jacobson's two-seater touched

COLT 45 CAL. AUTOMATIC \$1.00



Colt 45 Automatic pistol model kit \$1.00
Thompson Sub Machine Gun kit \$1.00

FREE OFFER
1 Colt 25 automatic pistol model kit FREE with order for \$2.00 or more.

Beautiful kit complete, best basswood, all parts cut to shape. Requires only short time to finish.

Send postpaid in U.S.A. No stamps, please.

GUN MODEL CO., Dept. F7, 2908 N. Nordica Ave., Chicago

8 SHOT BLANK REVOLVER

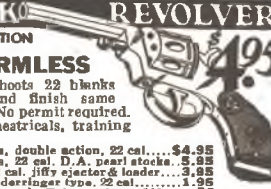

SAFE and HARMLESS

Celebrate the 4th; shoots 22 blanks only; construction and finish same as hi-grade firearms. No permit required. For starting races, theatricals, training dogs, etc.

- 8 Shot Blank Revolvers, double action, 22 cal. \$4.95
- 8 Shot Blank Revolvers, 22 cal. D.A. pearl stocked. 5.95
- 6 Shot Blank Auto., 22 cal. jiffy ejector & loader. 3.95
- 2 Shot Blank, 2 barrel derringer type, 22 cal. 1.95
- 100 Blanks FREE, with each. Extra cart. per 100. 50

\$2 deposit required on C.O.D.'s. Send 3c for bargain catalog; Rifles, Firearms, Air Guns, Telescopes, Knives, Binoculars, etc.

LEE SALES CO. (Dept. FA) 36 W. 32nd St., N. Y. City

Pilots and Future Pilots!

Affiliate with the aero club that offers REAL benefits to all members. Wear the wing pin of NAR.

Investigate the NAR benefits and you'll choose no other club. Prove it to yourself. Send 10c for membership details, application blank and copy of FLYING NEWS, the NAR club newspaper.

NATIONAL AERO RESERVE
Dept. F. 114 W. 16th St., N. Y. C.

32" OUTDOOR CABIN ENDURANCE



This contest ship has graceful lines and is simple to build. It has flown for 3 min., covering 3,000 ft. Kit comes with full size plan and complete instructions. All material necessary, including metal parts and finished 14" prop. Plenty extra wood. **\$1.00** postpaid

FREE! 4 full size plans with this kit!—350 DeWolfe D59, 210 Twin Tractor, 240 Curtiss AS Attack, 260 3/4 scale Stinson "Reliant"

CRESCENT MODEL AIRCRAFT, Dept. F-7, 8642-18th Ave., Brooklyn, N.Y.

PAUL OWINA
 Trade Mark Reg. Applied for
MODEL AIRPLANE PROPELLERS
 STRONGER THAN BALSA — HAND
 CARVED, PERFECTLY BALANCED, VAR-
 NISHED, ALL READY FOR MOUNTING.



**MODEL AIRPLANE
 JAPANESE TISSUE**
Brilliant
THIN AND STRONG
 IN 32 COLORS

Reference from Ohio—
 We have been selling your Japanese
 tissue for the past two years and it
 more than pleases our customers.

**MINIATURE
 CELLULOID
 MOTORS**



As direct importers
 from Japan for many
 years, in contact with
 the best sources of
 supply, we offer model
 airplane accessories at astoundingly
 low prices.
 Send 10c for sample motor or prop.
 Write for Quantity Discounts
We Pay Shipping Charges

WHITFIELD PAPER WORKS
 18 VESTRY ST. NEW YORK CITY
 (Established 1869)

the water not far from where Harvey Mason would come down. Another plane maneuvered to rescue the body of Yosuki Yomomato.

“GOOD work, Mason,” the squadron leader said, when they were alone, “I’ve radioed the admiral full details. It’s lucky, though, that the ground crew brought us back from that wild goose chase or you might have—got wetter than you did.”

“How about the international inci-

dent?” the pilot asked.

Commander Jacobson grinned.

“Fortunately for all of us, Yomomato had written instructions with him that protect you and me perfectly. Of course, we’ll go through the farce of returning the body of ‘a civilian aviator lost in the north Pacific’—but Washington will know.”

Harvey Mason nodded. Another “incident” had been closed. And Fate alone knew its bearing on the future of the Pacific.

Tactics and Strategy of Modern Sky Fighting

(Continued from page 19)

The trick here, of course, is for the three single-seaters to make their individual attacks perfect throughout.

AN interesting feature concerning this question of the single-seater versus the two-seat fighter will be noticed in Figure “C” of our illustration. In this we show a formation of two-seaters on an offensive mission. The point here is first to get the leader of the two-seater Vee and thus break up the keystone of the formation; for

as long as this flying wedge is intact, it is almost impossible to stop it, because the gunners are so set as to cover each other against all ordinary thrusts from the single-seaters.

Here, again, initial strategy plays a big part. The leader of the single-seaters splits his forces up into three three-ship elements and sets out his stage. The No. 1 element dives (see drawing) and comes up, and under, the leader of the attack Vee. The No. 2 element smashes in from almost dead astern, and the third flight noses down from above and slightly from one side. One of these three thrusts should get the leader out of the play. This means that the sub-leader will have to move in to take his place. This change in the setting hurts the two-seater formation. It has broken up the balance of gun-power and what is more, it has removed the main figure in the group—the leader. The remaining unbalanced line cannot work so smoothly because there is one ship that is not properly covered and this makes a great deal of difference. As long as the two-seaters can hold their close formation, they are comparatively safe, but as soon as one cog in this machine is removed, untold damage has been done to the whole flight plan. Figuring machine for machine, however, the two-seaters have got the edge on the faster single-seaters which attempt the tactics just described.

But while the two-seater is bad medicine for the single-seaters, the new modern bomber-fighter with its high speed and unusual gun power is the real cross that the single-seaters must bear. These multi-gun craft are very fast and must be approached from behind for an effective attack. Then the three-ship element again must stage its favorite game of harrassing gunners while one cleans up the job—if it can.

As shown in Figure “D,” two gunners must be taken care of on the bomber fighter. One plane feints at the upper gunner and keeps him occupied, and plane No. 2 must then draw the fire of the lower-tunnel gunner long enough to give Plane No. 3 a chance to hammer in from the so-called blind-spot behind the tail assembly of the bomber. This blind spot refers to the dead area created by the all-important tail, for neither rear gunner can fire in the angle blocked out by the rudder and elevators. It is from this angle that the No. 3 plane attacks, and his attack must be certain and ac-

The Greatest of Aviation Magazines

Flying Aces +



OR



=

A Combination that Can't Be Equalled!

NOT a day passes but that we receive a flock of letters from readers not only praising FLYING ACES to the skies, but expressing their appreciation of these fine free premiums, pictured above. And they are both beauties—the ring, finished in antique silver, is self-adjustable and guaranteed to fit, while the bracelet is equally attractive.

You may have either ABSOLUTELY FREE with a yearly subscription to FLYING ACES, and while we're about it, might mention that you may have a STERLING SILVER RING ABSOLUTELY FREE with a two year subscription. A yearly subscription to FLYING ACES, you know, is \$1.50, while a two year subscription is only \$2.50.

If YOU haven't taken advantage of this offer, do so at once. Don't rely on getting your copies at the newsstand, for if you're late you might miss out. Make sure of getting every issue of this great 96 page aviation magazine, with its large and unequalled model building department, its thrilling stories, interesting features, rare photographs and valuable data—all for 12c a copy, and that's what each issue costs you on a yearly subscription; or a fraction over 10c per copy on a two years subscription.

Take advantage of this offer and send that subscription in RIGHT NOW!

THIS OFFER GOOD ONLY IN U. S. AND POSSESSIONS

Subscription Dept., FLYING ACES, 67 W. 44th St., New York City.

Gentlemen:

Please enter the following subscription to FLYING ACES covering a period of years, for which I enclose my (check) (money order) in the amount of (\$1.50) (\$2.50) and start my subscription with the issue.

Name

Street and No.

City and State

Please send the article which I have checked: Ring Bracelet

curate, or he will find himself taking a terrible burst from one or the other.

Today, the single-seater no longer holds full sway in the air, particularly the individual single-seater. They must fight in tight groups and accept the law of formation—or be doomed. The fixed gun, once the menace of the air, has limited the single-seater pilot. He must now follow the law of safety in numbers.

That's the story of modern attack maneuvers in outline form. And now if you will study the diagram headed "Defense" you will note the varied formations in which military ships fly. In the lower part of this drawing, more-

over, the various flying tactics are reviewed.

It is to be pointed out, of course, that attack and defense actions are often inter-related. As in ground fighting, the best method of defense lies, more often than not, in attack.

Problems in air fighting must be studied and met individually. But the fundamentals explained in this article are the bases upon which the problems are solved, hence by knowing these primary maneuvers and tactics, you are well on the way to understanding the complications involved in modern air fighting.

Happy Landings

(Continued from page 29)

winged bombers and potting away at ranges varying from 500 to 700 yards. In reply, the bombers equipped with the Joyce gun can hurl shells at the rate of 100 a minute and get reasonable accuracy up to 1,000 yards. There we see the break in favor of the heavier bomber which in addition to having the Joyce gun also provides a far steadier platform for the gunners to work from.

There will be no aces in the next war—as we have said time and time again!

The point naturally comes up: What about American single-seaters being fitted with these motor cannons mounted under the cowl and firing through the prop? Couldn't that be done?

At the present time, most single-seaters in the U. S. Army or Navy are equipped with controllable-pitch airscrews and within a short time, there is no doubt that all will be so equipped. That's where the trouble lies, for the standard controllable-pitch prop now in use is not hollow to the extent that a

1-pound shell can be fired through the center. We shall have to develop one to keep up with the French who have commissioned the Ratier firm to build a great number of a new type designed especially for this duty.

The U. S. could buy cannon-fitted Hispano-Suiza motors and French Ratier props. But we feel that our Hamilton-Standard Propeller Company can turn out our props if the request is made.

FROM where we sit, it looks more than ever like the air will be filled with giant war-planes mounting cannon-fitted turrets.

All the designers have to do now is to get out a plane that is shell-proof—or at least find a new light armor suitable for use in airplanes. And that's really been the problem since they first started flying with carbines strapped to the center-section struts, twenty-two years ago.

Iceland's Shark-Shooting Air Mail

(Continued from page 12)

the herring bank. A trial burst spat from the machine gun. Jon swung the weapon around. I drew back involuntarily as the slugs zipped past my face.

The radio renewed its activity under Baldwin's practiced touch. I rightly deduced that an extra boat was being sent for. The sharks seemed to have completely surrounded the herrings, and I figured that they might well drive off the entire school.

Baldwin ceased his sending and gave his attention to the piloting of the ship. He whipped around so that Jon had a clear view of the threshing sharks. Then he nosed down, and skimmed the whitecaps alongside the fish. The machine gun beat a vicious tattoo. One of the train-oil sharks lashed out of the water, spurted blood, and turned over on its side. Baldwin coasted the plane alongside the shark, and Jon left his gun to grab up a pike pole. He swung open the door and stepped out onto the wing. The plane dipped. Jon hooked the shark with his pole.

THE interest of the sharks was now turned from the herrings. They began trailing the stream of blood that bubbled along behind the dead shark. Baldwin eased open his throttle, climbed up over the waves, and slid down into the troughs. The cannibals followed their erstwhile brother. Finally, they started snapping at the carcass, and one lunge almost pulled Jon and the pole into the water. The Iclander then let them have the kill and climbed back into the plane. He resumed his position at the gun, training it on the threshing man eaters.

They had bloodied the water and seemed to have sated their appetites. For a few moments they swam about in circles as though doubtful as to their next move. Then they turned as if to return to the herrings. Jon now whipped another burst into the middle of the shark school. Several of them were mortally wounded. This renewed their attention in their present locale. Baldwin started forward with renewed speed,

Build a Gas Model!

Send for our new plans of the two record-breaking ships.



The "BUCCANEER"

A flight-tested 7 ft. 4 in. wingspan model that can be powered with any reliable gasoline engine rated between 1/6 and 1/4 h.p. Simple construction enables every model builder to construct this ship. Costs less than \$10.00 to build.

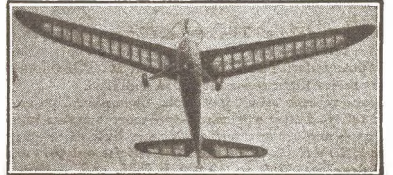

The "CAVALIER"

This is the ultra duration ship that flies 20 minutes on 1/4 oz. of fuel. Recommended as a contest ship for experienced model builders. 9 ft. wingspan. It can be powered with any gas engine of 1/5 to 1/3 h.p.

Worth Four Times The Price

50¢ EA

POSTPAID

Two big sheets 22" x 34" to each set. Accurate, clear and detailed.

Our new catalog is ready. Send for it. It's FREE. Just send stamp for postage.

BERKELEY MODEL SUPPLIES

53 BERKELEY PL., (F-13), BROOKLYN, N. Y.

LIGHT UP YOUR MODELS WITH HELIOS ELECTRIC LIGHTS



Note Navigation Lights

Wire up and illuminate your models with real navigation lights.

Genuine Midget Electric Bulbs, only 7/32" diameter, burning on any 2 cell battery.

CONTENTS OF KIT: 3 Lilliput Pea-Lamps, 1 red, 1 green, 1 white, each with 22" specially

thin flexible wire-cord; 1 miniature base connecting-plug to fit any flashlight or electric lantern or candle; complete instructions for installation, (or all 3 lamps white if desired for cabin or landing lights). Satisfaction Guaranteed. If Your Local Dealer is not yet supplied we will mail you complete Kit postpaid for only **85¢**

Wide awake dealers will appreciate the tremendous sales appeal of these lights. Sell on Sight—**WHITE NOW!**

HELIOS PRODUCTS CORP.

799 Broadway Dept. F-7 New York, N. Y.

BE A DETECTIVE

Make Secret Investigations

Earn Big Money. Work home or travel. Fascinating work. Experience unnecessary. **DETECTIVE** Particulars FREE, write to **GEO. G. WAGNER, 2640 Broadway, N. Y.**

Guaranteed 40 Power 2 1/2" Long Distance Telescope

Clearly bring distant object close to your eye. Easily see far away subjects magnified with the **TESTED Superior 40 Power Telescope**. Look from your roof or out of your window and far away sights become as clear as if you were on the spot when focused with this trusty **WINNERSCOPE**. See close-up of the moon, stars, sports events, etc. Can also be used as a microscope for scientific observation. Have fun with far away neighbors. Look at what they are doing and phone and tell them about it. They will wonder how you know. Makes objects miles away appear in front of you. A scientific achievement that defies competition. Durable, made, brass bound, 4 powerful lenses, 1 foot long closed, about 8 feet open. Made in U. S. A.

SPECIAL FREE OFFER
Order at once! We will include a genuine pocket telescope that closes to two inches. Fits the waist pocket! Great to carry for emergency sights. **Send No Money!** Pay postman \$2.48, plus postage, on arrival, or send \$2.48 with order and get postage free.
J. H. WINN MFG. CO., Dept. T3607-124 West 23 St., New York

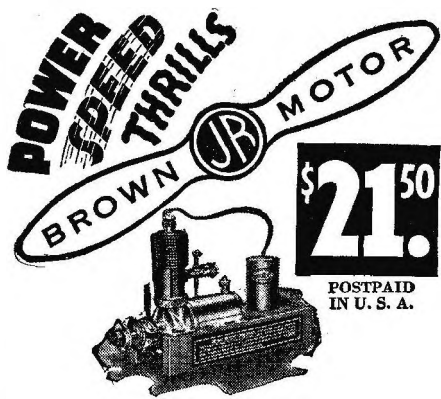

You Can Fly a Champion!

Here she is, fellows! The neatest, slickest job in a gasoline-powered motor ever offered to model plane enthusiasts. Jobs powered with BROWN JUNIOR MOTORS have held every major flight record for 1934 and 1935.

These records aren't just luck. Championships are won on quality—better workmanship—more stamina and reliability—and on greatest power per unit of weight. The bare BROWN JUNIOR MOTOR weighs only 6½ ounces, yet develops 1200 to 10,000 R.P.M. and delivers 1/5 horsepower. Can she PURR!

Fully covered by patents pending. No other like it. Only \$21.50 postpaid, no extras to buy. Guaranteed to run or money refunded. Send today!

● **MAIL COUPON — QUICK** ●

JUNIOR MOTORS CORPORATION, Dept. 15
2545 N. Broad Street, Philadelphia, Penna.

I enclose Post Office money order for \$21.50. Ship me prepaid at once your BROWN JUNIOR MOTOR, with all necessary information for correct installation and money-back guarantee.

Rush me detailed information, specifications, prices, etc., on BROWN JUNIOR MOTOR, the champion of model plane flights.

PRINT NAME _____
ADDRESS _____
CITY _____ STATE _____

DO YOUR FINISHED MODELS LOOK LIKE THE PICTURES!
Hundreds have learned that this modern way to cut balsa does away forever with slanted edges, uneven cutting, and hacked fingers. Operates either by hand or motor. Only One Dollar rushes a SPECIAL B A L S A - CUTTING SCROLL SAW to you, postpaid. Make sure your next models look neater and fly better by mailing a dollar bill today. C.O.D. if you prefer.

ONLY \$1.00 COMPLETE POSTPAID

CRAFTSMEN, Room 310, 1713 N. Mozart St., Chicago, Ill.

Be Sure to Read
The SPECIAL OFFER to FLYING ACE READERS
on pages 86 and 90 of this issue

FIREWORKS "4th of JULY" ASSORTMENT
Our wonderful assortment of fireworks only \$2.50, express prepaid, includes 100 extra 2 inch Salutes FREE. Worth \$4.00 in any retail store. A day's fun for the whole family. Remittance must accompany order. We ship same day received. Our free catalog of fireworks and novelties will be sent immediately on request. Write today.
THE BRAZEL NOVELTY MANUFACTURING CO.
4036 APPLE STREET CINCINNATI, OHIO

Everything in RADIO
FREE NEW RADIO CATALOG
Send for our new 198-page catalog—the Leading Radio Supply Guide. Packed with everything new in Radio—latest Metal Tube Tell-Eye sets, Battery and Auto Radios, new Build-Your-Own Kits—Sound Systems—thousands of parts at lowest prices. Write now for FREE Catalog.

ALLIED RADIO CORPORATION
833 W. Jackson Blvd., Dept. A.A., Chicago
 Send me your FREE Radio Catalog.

Name _____
Address _____

the plane bumped several times as the floats struck the crests of the rolling waves, then we climbed into the air. In the sky again we saw the herring bank moving northward toward the open sea.

I was wondering whether, after all the excitement, the fish were going to get away. Jon nudged my shoulder and pointed toward the approaching trawlers. They were signalled and directed toward the herrings in order to head them off and turn them inshore. A short time later the shark boat arrived, and we left it to the task of gathering in the Arctic fighters. Baldwin made his usual business-like notation on his chart, for with all the novelty to me, this was just business to Jon and Baldwin.

The balance of the trip was more or less ordinary, if flying over a succession

of volcanic mountains, smoking lava fields, and icy glaciers in order, can be called ordinary.

The return from the carriage of the mail was probably less than twenty-five dollars; but as you can well imagine, the percentage of commission on the fish and the train-oil sharks was a sizeable sum. It would subsidize a number of D 463's!

This one experience with Iceland and its air mail, shows the practicality that prompts the combination of effort. And a comparison of air transport with the old sea routes, that still take from twelve to fourteen days to go around the coast stopping at the ports as we did, and the pony routes in the interior, suggests that the Icelanders will find other means for developing their country with airplanes.

On the Light Plane Tarmac

(Continued from page 30)

you do not have to own an "A" license, but if you haven't, you sign up for nine weeks special training and they see that you get one. After that, its Avros, Siskins, Bulldogs, Furies, or what have you.

"Why haven't we got something like that?" you ask. Well, there is at least one ray of hope over here for those who want to fly. We refer to the latest report that the Navy is looking for pilots to serve in the Naval Reserve and the Marine Corps Reserve. The men to be selected must be between the ages of 20 and 28 and hold college degrees or the equivalent. They must, of course, also pass a physical examination.

The Commandant of each naval area is to be allotted a quota proportionate to the population of the district. For instance, in the Third Naval District, which includes the states of New York, Connecticut, and the northern half of the state of New Jersey, sixty candidates will be chosen.

Those interested should make application to the Commandant of their area. Successful applicants will be enrolled at once either in the Naval Reserve as seamen, second class, or in the Marine Corps reserve as privates, *first class*. (That difference in class ought to start a war in itself!)

Next, they will be sent to the nearest Reserve aviation base for "elimination flight training," which will include anything from ten to fifteen hours. If they show signs of being capable of learning to fly after that, they go on to Pensacola and are listed as flight cadets. The pay there is \$75 a month and an extra dollar per day subsistence allowance.

At Pensacola, the flight training lasts a year and in that time they get about 300 hours of flying on service type craft. From there they go to the Fleet, and the pay goes up to \$125 a month; and after three years of service with the Fleet as aviation cadets, a bonus of one year's pay is given and they return to civil life. Any who live near a Naval Reserve or a Marine Reserve depot can take a commission in either service.

LET'S SEE SOME ACTION, FANS!

WELL, we're still waiting to hear from you about *your* flying club and *your* light plane. This department is still hanging on, trying to get something done, but so far we frankly have not had a great deal of success. Our mail has been like the planes—light.

Are you really air-minded, or do you just like to read about it?

Come on now, let's have some real action!

The Flying Aces Parasol

(Continued from page 41)

also have to be glued over at least twice because they are apt to come apart otherwise. When this is done, cut the tail surfaces out of 1/32" soft balsa and smooth them down with fine sand paper. The stabilizer is cemented to the bottom of the stick and the rudder to the left side.

WING AND PROPELLER

FIRST trace and cut out the ten ribs of 1/32" soft balsa and then cut the spar notches while holding them all firmly together. Now pin down the 1/16" x ¼" hard balsa trailing edge and

cement-in the two center ribs at a slight angle, as shown in Plan 1. The rest of the ribs are at right angles to your work board. And now the 1/16" sq. hard balsa leading edge is fitted in edgewise. For tips, 1/16" reed is used, which is jointed to the leading and trailing edges (see Plan 2). The top spar is hard 1/16" sq. balsa cemented in the notches, and it runs all the way to the tips.

Cover the wing with Japanese tissue, using banana oil for adhesive, and spray it with water to tighten it up. Glue the two halves together so that the tips are

(Continued on page 94)

The **WINNER—**

it may be

YOU!



What a Chance This BOYS' LIFE Airmarks of Aviation Contest Offers YOU!

• You can be one of the three lucky boys who will win a dandy Iver Johnson Bicycle of Progress through the BOYS' LIFE Airmarks of Aviation Contest. * You'll enjoy entering this contest on your favorite hobby.

FIRST PRIZE is an Iver Johnson Super Mobike with all accessories, including oversize tires.

SECOND PRIZE is an Iver Johnson De Luxe Mobicycle with accessories and oversize tires.

THIRD PRIZE is an Iver Johnson Drop Bar Roadster with accessories and oversize tires.

HOW TO ENTER — Airmarks of Aviation Contest appears as a feature in the June issue of BOYS' LIFE, that popular magazine for all boys, on sale beginning May 20th at all newsdealers—10 cents a copy.

Three simple things to do! And as a part of the contest you read an exciting and true story of a

thrilling aviation adventure written by Captain Burr Leyson. Contest closes July 6th, 1936. All entries must be received on or before that date. Age limit 18 years and under.

Leo Fryer of 1617 South Kedzie Ave., Chicago, Illinois, winner of the February issue Airmarks of Aviation Contest, wrote: "Let me caution you to warn your prize winners hereafter before sending them the prize. For if I had a weak heart you would have a law suit on your hands. When I opened the box I felt suddenly faint. And who wouldn't with such a gift!"

Entry application, complete contest announcement, aviation story, and full details all appear in the June issue.

All you do is procure a copy of the June issue of BOYS' LIFE from your nearest newsdealer, or send 10c in stamps to BOYS' LIFE, 2 Park Avenue, New York.

DON'T MISS THIS BIG BIKE WINNING OPPORTUNITY . . . TEST YOUR WITS ON YOUR FAVORITE SUBJECT IN THE JUNE ISSUE OF BOYS' LIFE ON SALE BEGINNING MAY 20th

AIRCRAFT

1-4" TO THE FOOT SOLID MODELS



HOWARD MULLIGAN. All white \$35

The kit to build a solid model of this record breaker contains: Turned hardwood cowling, wood filler, colored lacquer, printed gold letters, an accurate detailed drawing, etc.

EACH AIRCRAFT KIT CONTAINS
 Liberal portions of colored lacquers and cement, finished pine wheels, colored insignias, rigging wires, most difficult parts cut to outline shape, detailed drawings, die cast Propellers and Pilots and many other fine features too numerous to mention.

All Wartime kits contain super detailed Machine guns. The following Kits contain detailed Radial Engines and spun metal Cowlings: Boeing P 26 A, Boeing F 4B4, Boeing F 4B3, Boeing P 12 E, Boeing P 12 F and Curtiss Goshawk.

Spad 13 Fokker D 7 Fokker D 8 Fokker Tripe. S. E. 5. Pursuit Waco Model "A" Nieuport 17 C1 Sopwith Camel New Monocoupe Albatross D5 Curtiss Hawk PGE Howard Mulligan	35 Cents Each 3 for \$1.00
Boeing F4B3 Boeing F4B4 Boeing P26A Curtiss Goshawk Curtiss BF2C1 Curtiss P12E Boeing P12F	40 Cents Each

DE HAVILAND COMET 50c
 For single kits add 5c postage.
 Personal checks add 10c extra.

No C. O. D. shipments, if your dealer cannot supply your order direct.

AIRCRAFT

DEPT C 3502 N. CICERO, CHICAGO, ILL.

NEW! Jimmie Allen

OFFICIAL MODEL FOR 1936 Air Races



Complete Construction Kit Only 75c

28 in. wing span; 20 in. overall length; min. weight 1 oz. High wing cabin model designed for duration. Free wheeling prop; shock-proof landing gear. Control surfaces adjustable, detachable. 75c at Skelly Oil stations. By mail, add 14c postage (\$1 postpaid to Canada), from

Country Club Aero Supply Co.
 5921 Holmes St., Kansas City, Mo.



OH BOY! WHAT FIREWORKS!

FREE

CATALOG AND COUPON

Return coupon with order for Fireworks and get big 35c box of SALUTES FREE FA-150

SPENCER FIREWORKS CO., POLK, OHIO

Free

Write for your Free Copy!

PHOTOGRAPHIC ALMANAC
 and Bargain Book of CAMERAS & SUPPLIES!

Explains latest inventions, methods in Photography and Home Movie Making, for fun and profits. Offers hundreds of amazing money-saving bargains in still and movie Cameras, Lenses, Films, etc. Used equipment accepted in trade. Satisfaction guaranteed! WRITE!

CENTRAL CAMERA CO., Est. 1899
 230 S. Wabash, Dept. FA7, Chicago, U. S. A.

propped 1/4" high. For the propeller, use a soft block 6" x 1" x 5/8". After the blank is shaped, start to carve it at the hubs and work toward the tips. The prop should be about 1/16" thick at the tips. A 1/4" copper washer and a small eyelet cemented in the center hole will finish the propeller. Now bend the motor hook, push it through the aluminum tubing and propeller, and cement it.

FLYING

HOOK one loop of 1/8" flat rubber between the front and rear hooks. Glide the model out doors with about 15 winds. In case your Parasol goes down steeply, push the wing ahead as far as

the rubber bands allow it and try it again. If it now stalls, work back until you arrive at a happy medium. In some cases the elevator trailing edges have to be warped up a little bit to get the correct glide.

After the ship is balanced up perfectly, wind it up to 50 turns and then gradually increase your winds at each flight until the maximum (200 winds) is reached.

(Editor's Note: And say, fans, how about clicking a picture of your FLYING ACES Parasol for publication on our "With The Model Builders" page? We want to see more stick models in that department.)

Make the Douglas Bomber

(Continued from page 38)

Make the nacelles next. Cut two pieces of wood from stock of the required length and round out with razor blade, or on a lathe if you have one. Refer to front view of nacelles. Then shave down the aft end of the nacelles, giving them a streamlined shape. See that they fit snugly into the leading edge of the wing.

With your razor blade cut out six propeller blades from sheet balsa and cement them to two hubs cut from scrap wood.

Cut all the landing gear struts to size and also the antenna to be fitted on top of the fuselage. Sandpaper all parts of the model, then begin the assembly.

ASSEMBLY

LAY the fuselage on a flat surface and prop it up in flying position with blocks. Cement the two stub wings to the fuselage in correct position, with blocks under them to hold them in place. While waiting for connections to dry, join the tail units to the tail with plenty of cement.

Cement the engine nacelles in place, then connect the other two parts of the wing, giving them the desired dihedral, as shown in front view. Put blocks under the wing tips to retain the dihedral until the the wing joints have thoroughly dried.

Lay your nearly completed model on its back and (applying plenty of cement) build up the landing gear with small strips of balsa cut with your razor blade. Straight pins may be used as axles for wheels.

Pin the props to the nose of the nacelles and put on the antenna at top of the fuselage. Use black thread as wire.

Do all filleting with putty or plastic wood, then sandpaper the entire model with fine sandpaper.

PAINT JOB

DOPE the fuselage and nacelles a dark blue. Wing and tail surfaces should be yellow. Many coats will have to be applied before a smooth finish is obtained. When the last of the coats have dried, paint in the window with white dope or lacquer bordered by black lines. Dope the fronts of the nacelles black and also the tires on the wheels. The solid horizontal stripes on the rudder in the plans should be red, the other horizontal stripes white. The vertical band should be blue.

The star on the wing should be white with a background of blue, and the small circle in the center is red. That completes your model—giving you the latest bombing ship of Uncle Sam's Air fleet!

Build the Senior Pacemaker

(Continued from page 33)

facilitate their attachment to the sides of the body, as illustrated in the front view drawing on Plan 4. When each of the struts are cracked, get the correct angle and cement immediately.

The landing gear struts are shaped from hard balsa to the design shown on Plan 1 and 4. They are streamlined, of course. By studying carefully how the shock absorbing wires are inserted into the top of the landing struts on Plan 4, it is a matter of a minute's work to stick a knife blade part way into the struts and then push the strut up into the wires, as shown in detail in the front view drawing. Apply cement where wood and wire meet. The landing gear struts are not glued to the body.

The lower shock absorbers are also made from wire and cemented to the inner sides of the struts. Wrap a little white thread around them and place a thin coat of cement all around. Slip on the hardwood wheels, and with a pair of nose pliers turn up the ends of the wire slightly, as shown.

The prop is carved from a hard wood block of balsa. White pine can be used if desired. Carve to the design shown on Plan 4. Balance carefully after the prop shaft hole has been made. Remember, it is necessary to have the front end of the prop shaft bent to shape. Then insert into the prop, follow with a couple of washers, and place the remaining length of wire through the nose

plug first before forming the curved hook.

At this time, you may attach the motor power, which consists of six strands of 1/8" flat rubber, to the prop shaft. Lower it down into the fuselage and then attach it onto the rear hook. Close the hooks a bit tighter, if necessary, to prevent the rubber from slipping out.

ASSEMBLY

EACH half of the wing is cemented to the wing braces. The dihedral angle must measure 1" on each side. The wing struts are next to be cemented. The position for these members are shown by the dotted lines extending from the lower longerons to the wing base. A small strip of balsa, designated by the letter S-1, is cemented between the struts. This is shown also by the dotted lines just below the wing base. The front view drawing shows the position of the small vertical braces lettered

S-2. Four of these are needed, two for each wing and one cemented behind the other.

FLYING

THE model is now complete. Check for alignment of surfaces. Before test hopping the model, glide it several times. In order to obtain perfect three-point landings all the time, it is important that at the end of the glide the tail drops and the nose lifts up slightly so that the landing wheels and tail wheel touch at the same time. If this does not occur, either the nose or the tail is too heavy. Remedy this by removing any excess weight at either point.

For trial flight, wind up full power and let the ship try taking the air R. O. G.

Okay, then fellows—hop to it! You'll find the Bellanca Senior Pacemaker is a great ship!

Something New! A Cut-Out Model

(Continued from page 47)

in the cockpit in front and below the streamline headrest.

Next take the rudder and headrest streamlining (one portion, marked "B") and fold it flat. Place the glue on the upper edge of the headrest, and the top and rear of the rudder only; for the bottom must be left open to form a streamline shape. This is done by in-

serting a lead pencil into the open bottom and curving the cardboard by simply bending it around the pencil. After you have finished and it is dry, glue this whole "B" section onto the fuselage. Then put headrest "O" inside it on top of "I".

THE WINGS

NOW you are ready to make the wings, which are built up in three sections—two outer panels and the center section. They are marked "D & E". "D" is the center section and "E" the wings. Cut out the inner part of the center section, for the fuselage goes into the hollow that is formed. After you have carefully cut out the hollow, bend (don't crease) the center section so that the two points meet at the rear, or trailing, edge. Apply glue to the rear edges and hold them firmly together until they are dry.

Now take the fuselage and put it in the hollows of the center section "D" in the position shown on the plan. If the fuselage does not set properly, cut the edges of the hollow, little by little, until it fits. Eye it front and side to make sure. Spread some glue around the fuselage and center section and let it dry.

Next take the wings "E" and fold (don't crease) them back until the trailing edges meet. Then glue the edges. When they have dried you may, if you wish, make spars, by folding over a strip of cardboard, and inserting it into

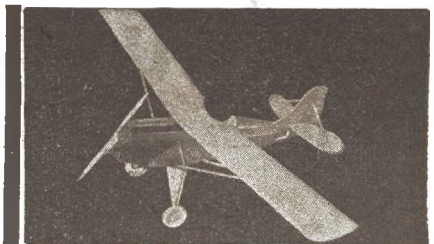

36-INCH CORBEN SUPER-ACE 75c
36-INCH FOKKER D-VII 75c
36" CURTISS GOSHAWK Complete Add 25c Postage on Each Kit \$1.00
FREE
With all orders for \$1 or over 2 oz. clear cement and 100 1/16 x 1/16 Balsa

Dealers, Clubs, Schools: Send for Price List
20 IN. FLYING PLANS 10c-3 for 25c
Sparrow Hawk, Boeing Trans. 247, Spad Chass., Vought Corsair, Curtiss Swift L. W., Waco Cabin Biplane, Douglas Dolphin, Boeing P12F, Fokker D-VII, S.E.5, Goshawk, Gee Bee, Boeing P26A, Fairchild 24 Cabin, Northrop Gamma, Monocoque.
18 IN. LENGTHS
1/16x1/8 25 for 5c
3/32x3/32 18 for 5c
1/8 x 1/8 16 for 5c
1/8 x 1/4 8 for 5c
3/16x3/16 8 for 5c
1/4 x 1/4 5 for 5c
1/2 x 1/2 2 for 5c
18 IN. SHEETS
1/64x2 4 for 10c
1/32 or 1/16 x 2 6 for 10c
3/32x2 5 for 10c
1/8x2 4 for 10c
3/16x2 3 for 10c
1/4x2 3 for 12c
1/2x2 2 for 15c
3" sheets double these prices
18 IN. PLANKS
1x1 1 for 7c 2x2 1 for 20c
1x2 1 for 12c 2x3 1 for 25c
1x3 1 for 15c 3x3 1 for 40c
JAPANESE TISSUE
1 doz., all colors, AA, 19c
SILVER TISSUE
20" x 24" each .05
SUPER-FINE TISSUE
White Only
Sheet 5c dozen 50c
DOWELS
1/16 x 6 doz. 5c
1/8 x 18 2 for 5c
THRUST BEARINGS
Small dia 10c, Lge. dia 15c
RUBBER
1/16x1/16 or .045 18 ft. 5c
1/8 flat 15 ft. 5c
CLEAR DOPE
1 oz., 5c; 1/2 pt., 30c
COLORED DOPE
1 oz. bot., all colors, 5c
CLEAR CEMENT
1 oz. bot., 5c; 2 oz., 10c
1/2 pt. bot. 35c
BALSA
MACHINE-CUT PROPS
5" 5c 6" 8c
7" 8c 8" 8c
10" 10c 12" 12c
BAMBOO
1/16x1/16x12 36 for 5c
1/16x1/4x15ea. 1c; doz. 10c
SHEET CELLULOID
6x8 5c 12x12 20c
DUMMY RAD ENGINE
1 1/2" x 1 1/2"; 2" x 2 1/2"; 2 1/2" x 3"
ENGINE AND COWL ATTACHED
1 1/2" dia. 20; 3" dia. 35c
CELLULOID PANTS
1/2" dia pair 18
1 1/2" dia pair 33
INSIGNIA SHEETS
24 Insignia and stripes 5c
WASHERS
1 doz. 1/8 or 1/4 1c
PROPELLER BLOCKS
1/2" x 1/2" 6 for 5c
1/2" x 1/4" 3 for 5c
1/2" x 1/8" 3 for 5c
1/2" x 1/4" x 10 2 for 5c
1/2" x 1/4" x 12 1 for 4c
1 x 1 1/2 x 12 1 for 7c
1 x 1 1/2 x 13 1 for 8c
METAL PROPELLERS
2 blades 3 blades
1 1/2" 10c
2 1/2" 12c
3 1/2" 15c
4 1/2" 20c
WOOD VEN. PAPER
20 x 30 for 10c
SHEET ALUMINUM
.0003x3 1/2" per ft. 1c
.005", 6x6 50c
.010", 6x6 60c
ALUM. TUBING
1/16 or 1/8 per ft. 8c
BALSA WHEELS
1" 2c 1 1/2" 4c
2" 10c 3" 17c
BIRCH WHEELS
1" 2c 1 1/2" 4c
2" 10c 3" 17c
CELLULOID WHEELS
1" dr. 5c 1 1/2" dr. 10c
1" dr. 7c 1 1/2" dr. 17c
ALUM. COWLINGS
1 1/2" 15; 2" 18; 3" 25
Specify whether anti-drag, closed, or open.
BOMBS
1/2" dia. 1 1/2" 7c 1 1/2" 3" 12c
GUNS WITH RING MOUNT
1 1/2" 10c 1 1/2" 15c
PURSUIT MACHINE GUNS
1/2", 1 1/2", or 1 3/4" ea. .05
WING AND TAIL LIGHTS
1 1/2" 10c, 1 1/2" 15c, 2 1/2" 20c.
MECHANICAL WATER SPRAYERS 15c
WIRE 2 ft. 1c, 25 ft. 30c
BUSHINGS 1 doz. 3c
MODEL PINS pkg. 5c
THINNERS, 1 oz. bot. 5c
REED 2 ft. 1c
SANDPAPER, pkg. 5c
PROP. SHAFTS, doz. 8c
NOSE PLUGS, doz. 10c

Answers

TO QUESTIONS ON PAGE 27

- 1—Earl Ovington carried the first sack of mail from Sheepshead Bay to Jamaica (Both on Long Island, N. Y.) on Sept. 4, 1911.
2—Harriet Quimby obtained the first woman's flying license in this country in July 1911. She was the first American to fly the English Channel, and she was killed near her home in Boston in 1912.
3—The first plane launched from a compressed-air catapult was flown by Captain Mustin, U.S.N., on Nov. 12, 1912. Eugene Ely was the first American to fly a plane off the deck of a warship on Jan. 19, 1911.
4—Canadian airmen who won the V.C. are Capt. W. A. Bishop, Lieut. A. A. McLeod, and Major W. G. Barker.
5—No. The Congressional Medal of Honor is given only to those serving with the Army, Navy, or Marine Corps on active service. Lindbergh was awarded the Distinguished Flying Cross.
6—The "Three Musketeers of the Air" were Baron Guenther von Huenefeld, Captain Herman Koehl, and Major James Fitzmaurice. In 1928 they made the first East-West non-stop crossing of the Atlantic.
7—The United States Navy leads in skill and efficiency in aircraft-carrier deck flying.
8—Blind men were recruited to man the microphones used for detection of raiding German aircraft—because their sense of hearing is much keener than that of men who can see.
9—Amelia Earhart was the first woman to fly across the Atlantic.
10—Dick Grace is the most noted plane-crasher stunt man in the movies.

Famous U. S. Navy Plane

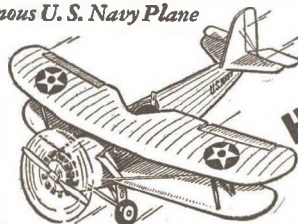

THE HELL DIVER

FREE BLUEPRINT
Choice of plans for
Winnie Mae, Laird
400, Akron Fighter.

MAKE THIS FLYING MODEL YOURSELF—Du Pont Duco Cement is quick-drying, easy-to-use and light in weight. Makes your model stronger. Send red disc from 25c tube for free blueprints. DUPONT, Dept. K-2, Wilmington, Del.

DUPONT DUCO Household CEMENT
TRANSPARENT • WATERPROOF

BUYERS' DIRECTORY

Airplanes and Accessories - Schools and Flying Instruction

FIVE DOLLARS PER INCH - PAYABLE IN ADVANCE

AIRPLANE SUPPLIES

New Aeroplanes Only \$25.00

down. The famous 98 Trainer, one and two-place, equipped with 700-4 Air Wheels, welded steel fuselage \$98.00 each and up. Can be powered with Ford, Siskely, any motor weighing 250 pounds or less. Propellers \$2.98 up; 40 h.p. motor \$49.98; 700 Air Wheels, including hubs, \$16.00 per set. Send 25c for more information and easy payment plan.

UNIVERSAL AIRCRAFT CO.,
Dept. 6, FT. WORTH, TEXAS



Join Karl Ort's Aviation League by sending me "two bits" (25c) today for my new 1936 Aviation Supply Catalogue and I'll give you one of these beautiful Pilot's Legal Pins absolutely free of charge while they last. You will be twice as happy because the catalogue will save you many, many dollars on your purchases.

KARL ORT, 627 W. Poplar Street, York, Pa.

What Goes On Behind The Scenes at Randolph Field

You'll find the answer in "Wings Over Texas". Written by a Flying Cadet just out of Kelly Field, "Wings Over Texas" will take you thru the day by day thrills, spills, and laughs that go into the making of an Army Pilot. If you liked "We", you'll want to read this! \$1.69 postpaid.

Air Specialties, 2028 Beachwood Dr., Hollywood, Calif.

PATENT ATTORNEY

PATENT YOUR IDEAS

Send me a sketch or simple model of your invention. **SATISFACTORY TERMS. DO IT NOW!**

FREE! Illustrated Literature Confidential Advice

Z. H. POLACHEK
1234 Broadway, N. Y.



APPRENTICE TRAINING

BE A PILOT ★
★ FLY A SHIP

If you are stumped at the high cost of training to qualify for a license and a good future in Aviation—write, enclosing stamp, for information on our

APPRENTICE PLAN

Mechanix Universal Aviation Service
INCORPORATED
Strathmoor Sta. Dept. K Detroit, Mich.

CLASSIFIED DIRECTORY

Use this Directory for prompt response. Rate: 10c per word (minimum 20 words). **CASH WITH ORDER.** Make remittances payable to:

HARRY SAUNDERS

Classified Ad. Manager, 230 West 41st St., New York.

MODELS—MATERIALS—EQUIPMENT

SEND 3c stamp for Free Glider and our new low price list. Curtiss Models, 236 Blake Ave., Bklyn, N. Y.

BOSTONIANS—Most complete line of kits and supplies in New England. Bay State, Comet, Continental, Megow, Scientific, Selley-Tex. Gas Models. Art's Supply, 686 Mass. Ave., Central Sq., Cambridge, Mass.

AIRPLANE EQUIPMENT—PHOTOGRAPHS

PHOTOGRAPHS—Aviators, planes, celebrities, scenic. All sizes. Sample and price list. 10c. Ralstin Photos, Dept. A, 612 No. Denny, Indianapolis, Ind.

AIR PILOT

If you have a pilot license or expect to obtain one, you can't afford NOT to belong to this organization. Send 3c in stamps for A. E. Bulletin. State age. Membership and Cadet Flight Brochures, 35c.

THE AMERICAN ESCADRILLE



"Composed of America's Present and Future Air Pilots."
STATION N, BOX 10, NEW YORK CITY

FREE SENSATIONAL ADVERTISING OFFER

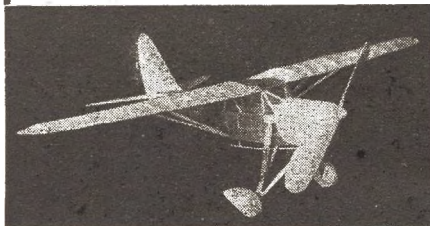

Yes! It's FREE. A 20-inch DeHavilland Leopard Moth flying scale model. Complete—nothing else to buy. Best quality materials and plenty of them. Just send 25c to cover cost of handling and mailing. Get our free catalog and see the sensational buys BALSACRAFT offers. Dealers, Clubs, Schools: Send for Price List

BALSACRAFT COMPANY

833 Third Ave., Dept. F 4, Brooklyn, N. Y.

LOWEST PRICED Gasoline Motors for

Boat and Airplane Models. Airplane Kit—Propellers—Balloon Tires—Boat Hull—Fittings, etc. Send 10c in coin for information and drawing of motor.

POWER MODEL

BOAT & AIRPLANE CO.
134 So. Clinton Street
Chicago, Ill. Dept. G-6



each side of the wings separately, near the leading edge. There is no need to use glue on them for the spars will hold themselves in position. Afterward glue the tips of the wings securely together. Set them aside, and take the pants "G," folding them so that they meet at the trailing edges where they are glued. When they are dry enough, you may put them in their proper places on the center section.

TAIL AND SUPPORTS

CUT out the tail wing halves "J" and spread some glue along the edge that goes to the fuselage. It is best to let glue get 'tacky' before placing the halves in position on the rear of the fuselage.

You will have to take the measurements for the cockpit windshield supports from the three-view. Cut strips of cardboard to the right length and width, and glue them. There are two main supports; one is set straight upright and the other, in the front, is slightly slanted. These in turn are braced with two side pieces and two front pieces. You will see them on the plan. When they have dried in position, take some cellophane from a cigarette package and cover the framework of cardboard with it. If you wish, you may use wire hairpins in place of the cardboard framework.

ASSEMBLY

THE wings are added to the center section by slipping them over it for 1/4" and gluing them in place. If they are too small, cut away some of the trailing edge of the center section until they slip over and fit perfectly. Set two blocks of wood beneath each wing tip to give the proper dihedral, just the same as you do with the balsa models. Let them dry and the wings are completed.

Cowl "H" goes directly in front of the windshield on the top of the fuselage. The motor cowl "C" comes next. It

is glued over the front end of the fuselage in the usual manner. Curve the cowl around the body and glue it.

Whether you want to make a motor for the plane or not is up to you. If you have the time and patience, build it up of any scraps of wood. Do it by cutting a crankcase out of a single block and placing the fourteen cylinders around it in a double staggered row. Then paint the engine black, put it inside the cowl, and add a match-stick, carved like a prop.

Or you may do as I did. I found a button of correct size, filled in the holes with a fillet mixture, painted it, and glued it 1/4" deep in the cowl. Then I put on the propeller (made of carved match-sticks) and my motor and cowl were complete.

Glue the wheels "L" in the pants, making sure they are even. Otherwise the model will not stand straight. Then add the radio mast "K" just in back of the cockpit. Glue it firmly and hold it upright with a pin until it is dry. Do the same with tail wheel streamline "M." Then insert the tail wheel "N."

Now your Northrop XFT-1 is ready for covering with the smoothed silver-foil. There is no trick to the job, for the foil is folded over the parts and glued securely. Add the red-white-and-blue stars on the wings and the strips on the rudder. Use two sandpapered match sticks for machine guns, and streamline them in by using a bit of silver-foil for a fillet. Paint them black.

The rigging on the radio is plain black sewing thread, glued in place. A piece of tooth-pick makes the balancers on the rudder and elevators. After they are glued in position, your model is finished—a "metal"-covered beauty you will be proud of!

If there are any questions you fans would like to ask, address me care **FLYING ACES Magazine**, 67 West 44th St., New York City, enclosing a stamped, self-addressed envelope.

WIN A FREE COAST-TO-COAST AIRPLANE TRIP

on a regular **TWA** SKY LINER

... or one of 10 FREE 1000-MILE TRIPS in Megow's new PRIZE CONTEST

Off to the terminal! There waits the air-liner of your dreams. Nine tons of metal—sleek, trim, mighty. Safety and security—and the thrilling call "All Aboard." The two mighty engines roar—you're off! A thousand miles—cities, rivers, the pleasant country, even cottony clouds flash under you. What a thrill for the prize-winning guests of Megow's Model Airplane Shop—as the great TWA Airliners in various parts of the country carry the proud winners of Megow's first contest. Can't you imagine your own delight at winning one of these 10 wonderful round trips? Each winner will start from the terminal nearest his or her home.

Here is all you have to do. Give us your suggestion for making a new Megow model, or for improving the Megow Kits from which you now build your favorite models. Write your suggestion in words, or draw it in complete sketch form. The eleven most valuable suggestions win. Read the rules of the contest. Send for a 20 page complete catalogue of Megow Kits.

• 1000 OTHER PRIZES •

RULES of THE CONTEST

1. Give us your suggestion in 200 words or less—or by a complete and detailed drawn sketch—for a new Megow Model or suggest how Megow can improve the Kits now being made.

2. Do not build or send a model.

3. Each suggestion entered in the contest must be accompanied by the ends of cartons from 3 DIFFERENT Megow Kits.

4. All suggestions entered become the property of Megow Model Airplane Shop.

5. Prizes to be awarded for the best and most practical suggestions as follows:

FIRST PRIZE — Coast-to-Coast round trip by regular TWA Airliner.

NEXT 10 PRIZES—Round trips on TWA Airliners, each equal to 1000 miles of travel.

1000 PRIZES — Fifty-cent solid model airplane Kit made by Megow Model Airplane Shop.

Every entry will receive a copy of Megow's new book "The A.B.C. of Model Building."

6. Each entry must be accompanied by name of dealer from whom models were purchased—or by the name of a dealer in your town from whom you want to buy Megow Models.

7. Judges decisions are final.

8. All entries must be post-marked before midnight August 31, 1936. Winners will be notified by September 15th.

Mail this Coupon for big, new Catalog!



MEGOW MODEL AIRPLANE SHOP—Dept. F.A., Howard and Oxford Sts., Philadelphia

Inclosed is a 3-cent stamp. Please send me your big 20-page catalog of Megow models.

Name.....

Address.....

MEGOW'S MODEL AIRPLANE SHOP

Howard & Oxford Sts., Philadelphia

CHICAGO OFFICE & WAREHOUSE—627 LAKE ST., CHICAGO

Build this
Ship Model
and win a
Free Trip
to Europe
aboard the
Superliner

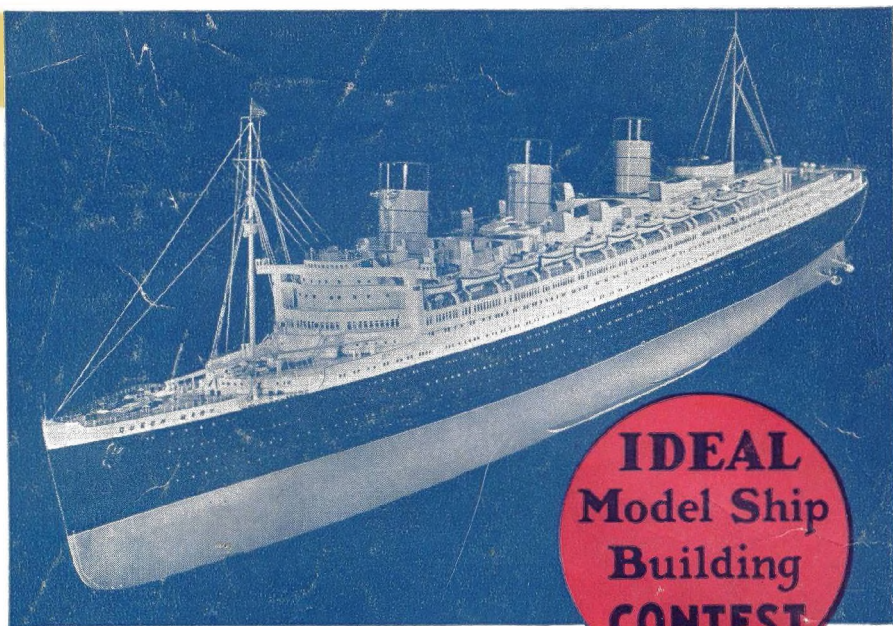

**IDEAL
Model Ship
Building
CONTEST**

QUEEN MARY

*Wonderful
Prizes!*

CELEBRATE the arrival of the Newest Greyhound of the Seas by building your own beautiful Model of the new Cunard-White Star Superliner. Here is a Ship Model that will excite the admiration of the most critical model builder. It is a remarkably accurate and realistic reproduction of the huge ship, with a wealth of intricate detail duplicating all the distinctive features. Even with such an abundance of detail, the Model is very easy to construct; all the tedious work usually required has been eliminated, much of the material is ready to use and the builder can start construction immediately, and finish it quickly.

- 1st**—Trip to Europe and Return on the Queen Mary, all expenses paid, cabin class.
 - 2nd**—Trip to Europe and return on the Queen Mary, all expenses paid, tourist class.
 - 3rd**—\$50.00 in cash, also 27 more Cash Prizes, Hundreds of Trophy Cups and Commemorative Medals.
- Full List Included in Every Kit.



This is the exclusive IDEAL Hollow Hull (Patent Pending), fully shaped and with arrangement for electric lights if desired.

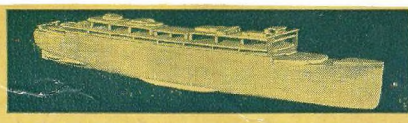

Here is the partly completed ship with decks in place. At right, additional details added, and the Model ready for finishing.

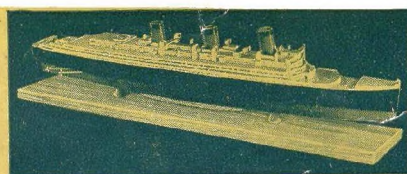

Complete IDEAL Official Contest Kit with New **Redi-Form** Hollow Hull

The most important improvement ever invented for ship model construction is the new IDEAL "Redi-Form" Hollow Hull, included in this Kit. It is molded to the exact shape of the ship, fully and completely shaped inside and outside, and is ready for mounting decks and super-structure. Decks are outline printed on balsa wood, ready to be cut out and attached to hull. Enclosures for promenade decks, bridge and other enclosed parts are clearly printed on heavy cardboard, ready to be cut out and attached. Ready to use materials for funnels, deck housings, masts, booms

18 in. Model



Plus 10c Postage

and other details. 22 cast metal lifeboats and davits for same; 2 metal anchors, 4 brass propellers, plenty of cement, colored lacquer for decorating, sandpaper and such items are furnished. A large Plan, full size of the Model, is included. Shows every operation; contains 40 enlarged detail diagrams, 10 actual photos showing construction; also full instructions for building, outfitting and decorating your Model.

Anyone can build a beautiful Model with this Kit, expert experience is not necessary.

Get your Kit and Start Now!

Build your own Model of this Wonderful Greyhound of the Seas; do it now while everybody is interested in this gigantic new ship. Enter this Contest. Entry Blank, Contest Rules, List of Judges and a Coupon entitling you to a pass to visit the ship included in every Kit. Ask your Department Store, Toy Store, Craftsman or Hobby Shop for the IDEAL Official "Queen Mary" Contest Kit, or send your order on the coupon and get busy right away!

The IDEAL Company

21 West 18th Street

New York, N. Y.

The IDEAL Company,
21 West 18th Street, New York, N. Y.

Please send me IDEAL Official QUEEN MARY Contest Kit (s). I am enclosing \$1.00 for each Kit, plus 10c for postage.

Print Name

Address

City State